



ELSEVIER

## A high stability light emitting diode system for monitoring lead glass electromagnetic calorimeters

D. Autiero<sup>a</sup>, M. Baldo-Ceolin<sup>b</sup>, F. Bobisut<sup>b</sup>, A. Cardini<sup>a</sup>, P. Cattaneo<sup>c</sup>, V. Cavasinni<sup>a,\*</sup>, C. Conta<sup>c</sup>, T. Del Prete<sup>a</sup>, A. De Santo<sup>a</sup>, R. Ferrari<sup>c</sup>, V. Flaminio<sup>a</sup>, M. Fraternali<sup>c</sup>, D. Gibin<sup>b</sup>, S.N. Gninenko<sup>d</sup>, R. Grabit<sup>e</sup>, A. Guglielmi<sup>b</sup>, E. Iacopini<sup>f</sup>, A.V. Kovzelev<sup>d</sup>, L. La Rotonda<sup>g</sup>, A. Lanza<sup>c</sup>, M. Laveder<sup>b</sup>, F. Martelli<sup>b</sup>, M. Mezzetto<sup>b</sup>, F. Pastore<sup>c</sup>, E. Pennacchio<sup>c</sup>, G. Polesello<sup>c</sup>, G. Renzoni<sup>a</sup>, C. Ricci<sup>f</sup>, C. Roda<sup>a</sup>, A. Sconza<sup>b</sup>, G. Stefanini<sup>e</sup>, M. Valdata-Nappi<sup>g</sup>, M. Veltri<sup>h</sup>, L. Visentin<sup>b</sup>, S.A. Volkov<sup>d</sup>

<sup>a</sup>Dipartimento di Fisica, Università di Pisa and INFN, Sezione di Pisa, Pisa, Italy

<sup>b</sup>Dipartimento di Fisica, Università di Padova and INFN, Sezione di Padova, Padova, Italy

<sup>c</sup>Dipartimento di Fisica Nucleare e Teorica, Università di Pavia and INFN, Sezione di Pavia, Pavia, Italy

<sup>d</sup>Institute of Nuclear Research, INR, Moscow, Russian Federation

<sup>e</sup>CERN, Geneva, Switzerland

<sup>f</sup>Dipartimento di Fisica, Università di Firenze and INFN, Sezione di Firenze, Firenze, Italy

<sup>g</sup>Dipartimento di Fisica, Università della Calabria and INFN, Gruppo collegato di Cosenza, Cosenza, Italy

<sup>h</sup>Dipartimento di Fisica, Università di Urbino and INFN, Sezione di Firenze, Firenze, Italy

Received 18 July 1995

### Abstract

We have designed, built and tested a high stability system based on blue light emitting diodes (LED) and current pulse generators for calibration and monitoring of lead-glass calorimeters. This apparatus is presently being used for the electromagnetic calorimeter of the WA96 (NOMAD) experiment at CERN. The system was developed to minimize the sensitivity to temperature variations, different loadings, and ageing effects. Tests performed both in the laboratory and in the experiment showed that the response of the lead-glass calorimeter modules to LED light pulses could be kept within the precision of  $\pm 1\%$  for periods of several months.

### 1. Introduction

Direct injection of calibrated light pulses is the most suitable method to monitor calorimeters made of homogeneous transparent material such as crystals and lead-glass blocks. In fact in this way all components contributing to the final calorimeter response can be tested globally: transmittance and reflectivity of the light inside the block, efficiency of the optical coupling to the photodetector, gain of the photodetector and of the associated electronic chain (amplifiers, shapers, ADC). A high stability and reproducibility of the generated light pulses is required. The wavelength spectrum of the monitoring light pulses should be as similar as possible to the one generated by the incident particles; in case of lead-glass, to the Cherenkov light.

Most of the solutions proposed in previous experiments were based on the use of a single pulsed light source, usually a xenon flash lamp [1] or a laser [2], and on splitting and distributing the beam to the individual calorimeter modules using optical fibres. There are two major limitations to this scheme: (a) the need to monitor the stability of the light pulses to account for possible large pulse to pulse variations and (b) reduced flexibility in the modularity of the calorimeter. In effect the mechanical assembly of the fibre connections must be "frozen" from the test beam configuration to the final position in the experiment, since connecting/disconnecting fibres and modifying fibre curvature and geometry can alter the light yield by several percent.

We have adopted a different approach: each calorimeter module is equipped with individual light emitting diodes (LEDs), driven by individual high stability current pulsers. The approximate wavelength matching is achieved by using blue light emitters.

\* Corresponding author. Tel. +39 50 880111, fax +39 50 880317.

This monitoring system has been installed on the electromagnetic lead-glass calorimeter of the NOMAD (Neutrino Oscillation experiment with Magnetic Detector) experiment at CERN [3]. The calorimeter is designed for operation in a 0.4 T transverse magnetic field. The LED system was first used during the calibration in an electron test beam, without magnetic field, in subassemblies of 64 blocks (modules). The modules were then reassembled in the final experimental configuration, an array of  $35 \times 25$  blocks, and operated in the magnetic field.

In this paper we report the test beam and laboratory results we have obtained and we give a preliminary evaluation of the LED monitoring system performance in the final calorimeter configuration.

## 2. Blue LED characteristics

The choice of the type of LED was constrained by the requirement that the emitted light spectrum should match as closely as possible the Cherenkov spectrum generated by the electromagnetic shower. Calculations were done taking into account the emission spectrum, the transmittance of the glass and the quantum efficiency of the photocathode (77 cm in diameter) of the tetrode (Hamamatsu R2186-01). The results for blue and green LED emitters are shown in Fig. 1, where all parameters are folded in. The figure also includes, for comparison, the spectrum obtained using an alpha particle source ( $^{241}\text{Am}$ ) in an NaI(Tl) scintillator as used in previous experiments with lead-glass calorimeters [5]. The figure shows that the best match to the Cherenkov light spectrum is obtained with the blue LEDs, which are SiC emitters peaking at 470 nm with a diffusing plastic dome [4].

The NOMAD lead-glass electromagnetic calorimeter is

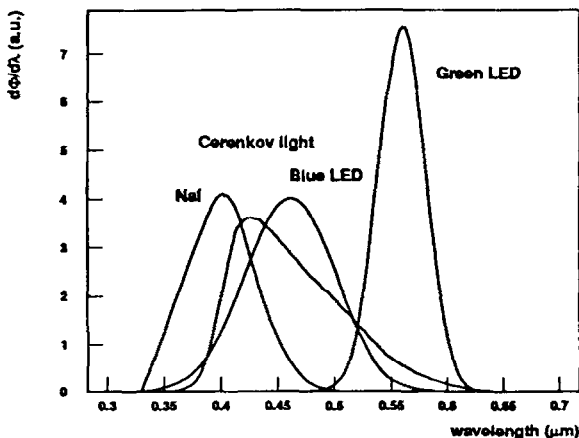

Fig. 1. Spectral distributions of Cherenkov light emitted in the lead-glass, of light emitted by green and blue LEDs and by a NaI/ $^{241}\text{Am}$  source. The distributions shown were obtained convoluting the emission spectra with the transmission spectrum inside the lead-glass and with the photocathode spectral response.

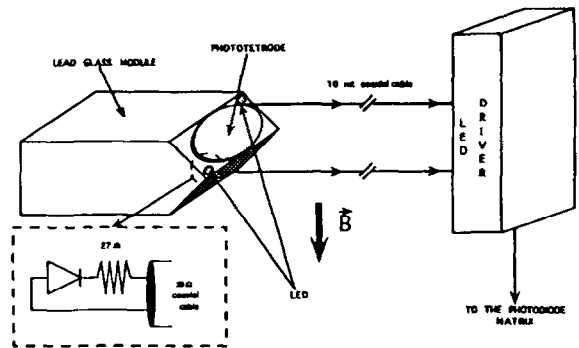

Fig. 2. Sketch of an individual lead glass block. The positions of the up and down LEDs are also indicated.

designed for operation in a 0.4 T transverse magnetic field. For this reason, the glass blocks have the rather unusual geometry shown in Fig. 2. The blocks are aligned orthogonal to the magnetic field. The block ends on which the light is collected, are machine cut at  $45^\circ$  with respect to the block axis, to limit the effect of the magnetic field on the photodetectors.

Each block is equipped with two LEDs (called up and down) positioned at the two opposite corners of the square end face on which the tetrode is mounted (Fig. 2). In this configuration the spatial distributions at the photocathode of the LED and of the Cherenkov light pulses are very similar, so that the signal reduction induced by the magnetic field (about 20%) is approximately the same (within  $\approx 1\%$ ) (see Section 5).

## 3. The LED current driver module

The LEDs are current driven using a long-tail pair design as shown in the schematic diagram in Fig. 3. The standing current is accurately set through a feedback loop which includes a low offset, low drift operational amplifier. Current switching ensures excellent stability in the total charge delivered to the LED. The switching is obtained with ECL compatible inputs and is quite fast ( $\approx 5$  ns), as measured on the on-board LED used for monitoring and display.

However, this switching speed was not exploited in our experiment, since the drivers had to be installed on the calorimeter platform at a distance of 10 m from the calibrating LEDs, connected via ribbons of coaxial cables. The coaxial cable introduced an equivalent load capacitance of  $\approx 1$  nF. The time and amplitude response of the LED light pulse was therefore determined by the charging of the cable up to the LED threshold voltage, which in the case of SiC LEDs is rather high ( $\approx 2.5$  V). In order to minimize the reflections due to cable impedance mismatch, a series resistor of  $27 \Omega$  was included in the LED termination. A parallel load resistance of  $\approx 10$  k $\Omega$  was also included to allow the cable capacitance to discharge

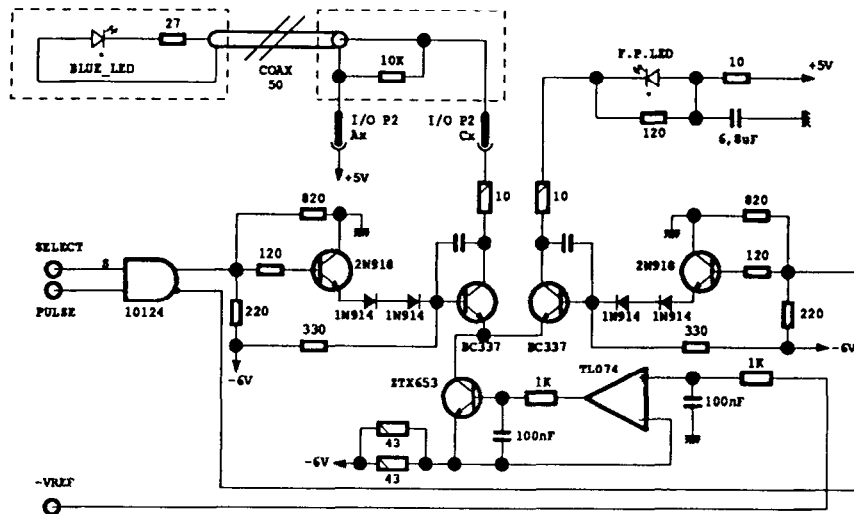

Fig. 3. Schematic diagram of the LED driver circuit.

between consecutive pulses. The overall response of this circuitry showed a delay of 100 ns in the turning on of the LED. On the other hand, the duration of the light pulse had to be kept below  $\approx 200$  ns on account of the shaping time constant of the charge-sensitive preamplifier.

We found that the best results were obtained with  $I = 26$  mA and  $\Delta t = 220$  ns, corresponding to the calorimeter response to an electron of 10–20 GeV energy, well within the range of real electrons detected in the NOMAD experiment.

Significant differences in response among different channels were observed due to the spread in the LED characteristics. In order to minimise such disuniformity a selection of LEDs was carried out as discussed below. Using the settings indicated above a very good overall stability was achieved controlling with a very accurate precision (35 ps) the duration of the current pulse. The shaper/preamplifier output showed typically a variation of 3% in amplitude for a change of 1% in the current pulse height. However, this amplitude was controlled within  $10^{-4}$ . Additional signal variations were induced by temperature changes, with the contributions of opposite sign from the cable capacitance and from the LED response. The overall temperature dependence resulting from the folding in of the various effects was measured and is discussed in the following section.

The uniformity of driver response was determined by connecting individual channels in turn to a single reference LED and measuring the light response in a stable and well controlled setup. We found an approximately gaussian distribution with a FWHM  $\approx 5\%$  (Fig. 4).

The current drivers are housed in single-width 6U VMEbus modules. Each module consists of a mother board, containing decoding circuitry and ancillary logic, and of an add-on analog board, with 32 channels of LED drivers. Each channel can be individually addressed.

In the NOMAD experiment, we used 60 such modules, housed in 6 VME crates. In each module (driver), the last two channels were sent to LEDs read by an independent photodetector (a photodiode) to monitor the overall driver behaviour.

#### 4. Laboratory tests

The entire set of  $\approx 3000$  LEDs, which was delivered by the manufacturer in several batches, was tested prior to mounting on the detector blocks. The test consisted in measuring the light pulse amplitude, in a stable setup, under the same conditions as used later in the experiment.

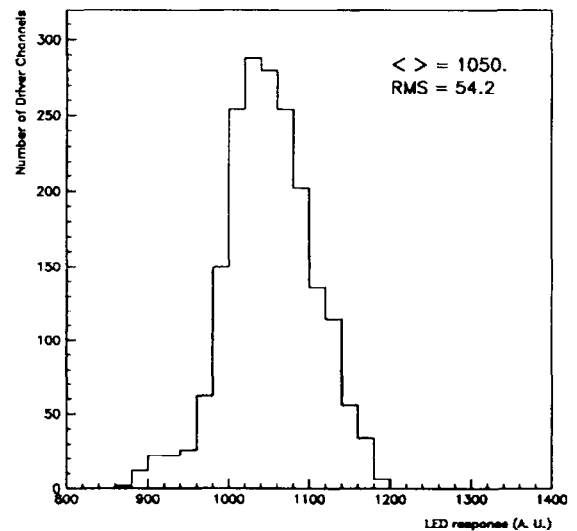

Fig. 4. Distribution of the current yield of all driver channels measured by a given LED.

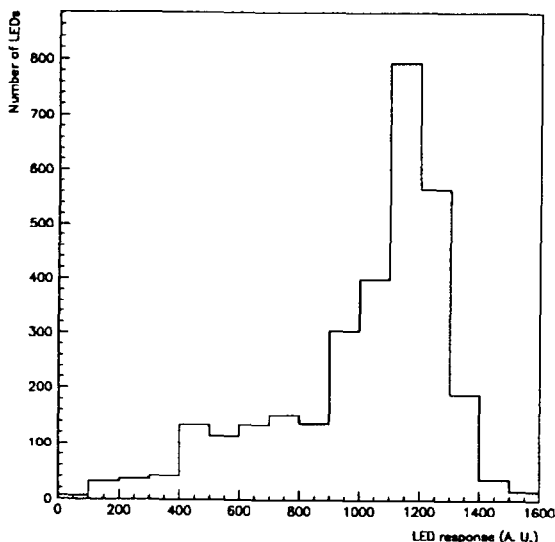

Fig. 5. Light yield of all LEDs measured prior to the installation in the calorimeter. LEDs within 900 and 1400 in the figure were accepted.

The current pulse, of 220 ns width, was provided by one channel of a driver module, via a 10 m long coaxial cable. The distribution of light pulse amplitudes for the entire set of LEDs is shown in Fig. 5. We selected and mounted on the detector only the LEDs yielding a light pulse amplitude in the range of 900 to 1400 ADC counts. We found that 70% of the devices (approximately) satisfied this constraint. The pulse amplitude distribution of this sample showed an rms width of  $\approx 20\%$ . Long-term stability tests were in addition carried out over several months on some LEDs (in zero magnetic field conditions) in order to test the temperature and aging effects.

Fig. 6 shows the experimental setup for these tests.

LEDs were housed at the four corners of the lead-glass end face (close to the tetrode window). The gate to the current driver was provided by a precision pulse generator (LeCroy Mod. 9210), with specified time jitter and stabili-

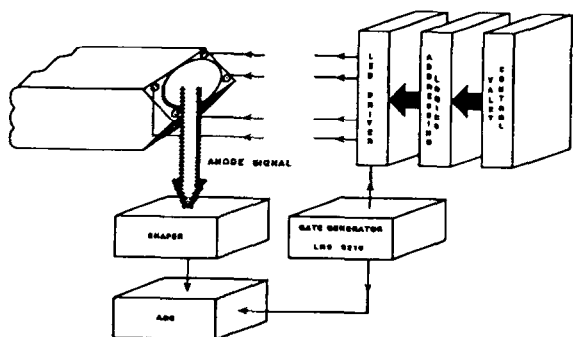

Fig. 6. Schematics of the laboratory setup to monitor the LED response.

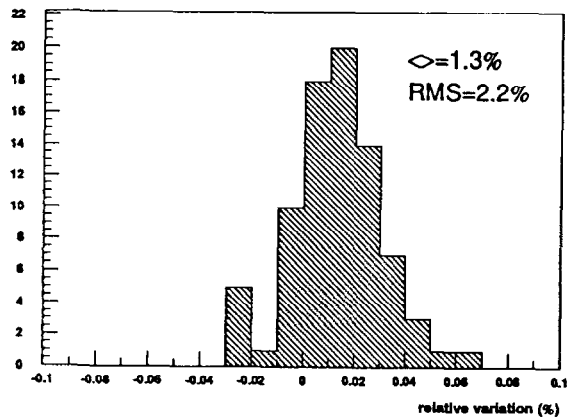

Fig. 7. Distribution of relative variations of LED signals over a four month period, as measured in the laboratory.

ty better than 35 ps. The amplitude of the preamplifier/shaper output signal was measured with a CAMAC peak sensing ADC (LeCroy mod. 2259B).

Data were collected in runs of about 0.5 h every 6 hours, with the LEDs continuously pulsed at a fixed rate of 200 Hz.

Typical runs collected 1372 events per LED which, together with dedicated pedestal runs, were recorded for offline analysis. Each of the four LEDs was pulsed in sequence. The temperature was measured and recorded by using a precise thermocouple, for each LED run.

The distribution of signal variations of the four LEDs over the entire test period ( $\approx 4$  months) is shown in Fig. 7. The average variation was  $\approx 1.3\%$  with  $\sigma(\text{rms}) \approx 2.2\%$ . These variations are well accounted for by temperature effects in the individual LEDs, which show a temperature dependence varying from  $+0.2$  to  $-1.0\%$ . We checked that this temperature dependence is indeed to be attributed to LEDs and not to the electronic chain by heating separately individual components (driver, shaper). No appreciable variations could be detected. When the appropriate individual temperature coefficients are folded in, the average variation is peaked around zero with  $\sigma(\text{rms}) \approx 0.9\%$ , as shown in Fig. 8.

### 5. Calibration and stability results

The absolute calibration of the NOMAD calorimeter was performed with 10 GeV electrons at the X5 SPS beam at CERN, in period October–November 1993. The calorimeter was calibrated in subsamples of  $16 \times 4$  lead-glass blocks in the absence of magnetic field. For each individual block the signals obtained using 10 GeV electrons and those using each of the two LEDs were separately recorded (see Fig. 2).

The calibration obtained with no field was transferred to

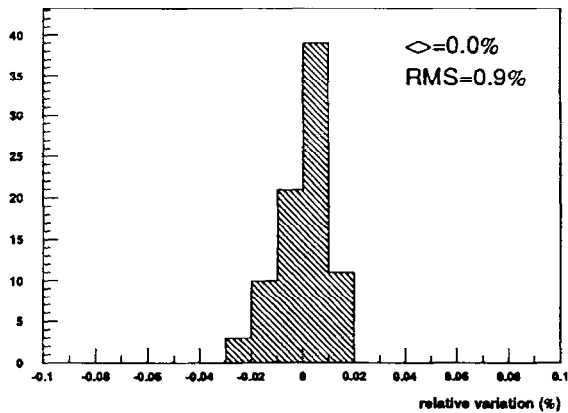

Fig. 8. Same as Fig. 7 after correcting for temperature dependence.

the real experimental condition with the calorimeter in the magnetic field using the LED signals. This procedure corrects for the loss of the tetrode gain due to the magnetic field that, in our experimental configuration, is about 20%. The magnetic field modifies the photoelectron trajectories in the tetrodes and as a result a fraction of the photocathode becomes useless for light detection. Since the electromagnetic showers are diffuse light sources, while LED are pointlike sources and also the optical paths can be very different, one could expect differences in the losses due to magnetic field for the two sources of light. To minimize these differences, we used diffusive LEDs and we positioned them at the end of the blocks, near the tetrodes to double the optical paths.

At the test beam, on a subsample of 52 lead-glass blocks, we accurately checked that the reduction in pulse-height due to the magnetic field measured with electron showers and the one measured with LEDs were the same. Fig. 9 shows the distribution of the quantity RR defined as:

$$\text{RR} = \frac{(\text{electron}_{\text{B-on}} / \text{electron}_{\text{B-off}})}{(\text{LED}_{\text{B-on}} / \text{LED}_{\text{B-off}})}$$

We found  $\text{RR} = 1.023$  with a spread of 0.8% for up

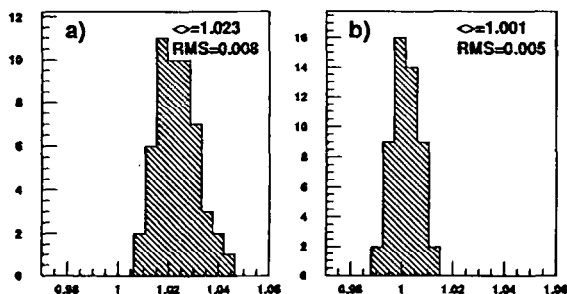

Fig. 9. Distribution of the ratio RR (see text) for up (a) and down (b) LEDs.

LEDs and  $\text{RR} = 1.001$  with a spread of 0.5% for down LEDs. The two RR distributions do not coincide due to the not uniform illumination of the tetrode photocathode by the two LEDs, and the presence on it of a "blind" zone caused by the magnetic field.

This comparative study of the behaviour of electron and LED signals in a magnetic field was repeated at the test beam after about one year with no change in the results within 1%. The appropriate calibration constants in the experiment were eventually computed using the signal reduction of the down LEDs that is identical (within errors) to the reduction of signal from electron showers.

The stability during the six months long 1994 neutrino run at the SPS was monitored by the pulse heights of both up and down LEDs, about twice per week.

During the run we found that a fraction of the LEDs mounted in the modules were affected by "jumps". A "jump" is a decrease of about 10% of signal which occurs in a very short time (about 30') between two stable conditions. An example of "jump" is given in Fig. 10. We do not have a clear explanation of this phenomenon: we observe that this problem seriously affects the second batch of LEDs delivered to us. These equip the last six modules, as shown in Fig. 11 which shows the average number of jumps per module per month. Such jumps have not been a real problem for the calorimeter calibration: in fact due to a low jump rate, the probability of a jump of both LEDs in the same block between two subsequent calibrations runs is completely negligible and the calibration can always be recovered using the second LED whose signal is not affected by a jump.

Fig. 12 shows the variation of all the LED signals in the NOMAD calorimeter in six months of data taking (after correcting for the jumps and for individual temperature variations): the average variation is zero with a spread of 1%. Fig. 13 shows the behavior as a function of time (months) of the average of the distribution of the ratio of all LED signals to the signals taken in the initial reference run and of its width. From Figs. 12 and 13 we see that

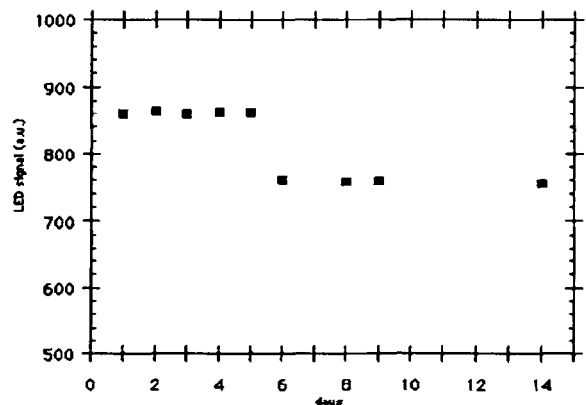

Fig. 10. Example of a LED jump (see text).

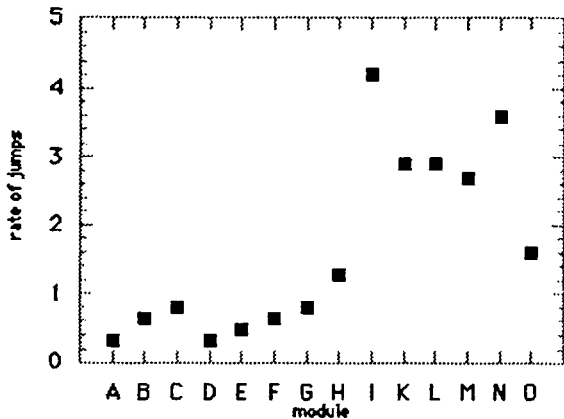

Fig. 11. Number of jumps per module per month; modules are denoted by letters A to O.

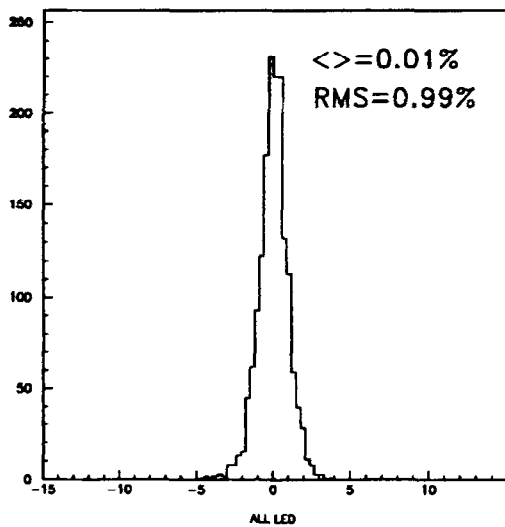

Fig. 12. Distribution of the variations of all LED signals in the NOMAD calorimeter after six months of data taking.

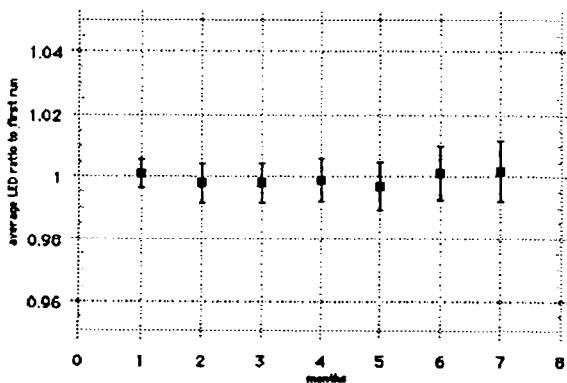

Fig. 13. Behaviour as a function of time (months) of the average ratio to the initial calibration run of all LEDs in the calorimeter; the error bar in each point is the RMS of the corresponding distribution.

there are no systematic effects or drifting of the LED signals while a slight increase of the dispersion may be noticed.

### 6. Conclusions

We have developed a modular and flexible system using LEDs for the relative calibration and monitoring of a large lead-glass electromagnetic calorimeter.

Blue SiC emitters allow good matching with the Cherenkov emission spectrum. Redundancy is built into the system by using two independent light sources for each lead-glass block. A stability better than 1% over several months has been achieved by using high stability current drivers and by applying linear corrections for temperature effects.

### Acknowledgements

We are very grateful to G. Goggi for his fundamental contribution in the initial stage of the experiment to the setting up of the Italian collaboration and for his precious help in planning the Italian contribution to NOMAD.

We deeply thank the technical staffs of the Cosenza, Firenze, Moscow, Padova, Pavia, Pisa groups for their invaluable contributions. We are particularly indebted to G. Fumagalli for his contribution to the on-line data acquisition system. We also wish to thank D. Rizzi who greatly contributed in the setting up of the temperature probes in the experiment and participated in the laboratory tests of the LEDs.

Financial supports from the Istituto Nazionale di Fisica Nucleare (INFN) to the Cosenza, Firenze, Padova, Pavia and Pisa groups and from the INR to the Moscow group are acknowledged.

### References

- [1] T. Sumiyoshi et al., Nucl. Instr. and Meth. A 271 (1988) 432; L. Bartoszek et al., Nucl. Instr. and Meth. A 301 (1991) 47; J.A. Bakken et al., Nucl. Instr. and Meth. A 280 (1989) 25; Y. Kubota et al., Nucl. Instr. and Meth. A 320 (1992) 66.
- [2] B. Powell et al., Nucl. Instr. and Meth. 198 (1982) 217; OPAL Collaboration, Nucl. Instr. and Meth. A 305 (1991) 275.
- [3] Experiments at CERN in 1994, CERN Grey Book 1994.
- [4] Taiwan Liteon Electronic Co. Ltd., Taipei.
- [5] J.S. Beale et al., Nucl. Instr. and Meth. 117 (1974) 501.
- [6] The electromagnetic calorimeter of the NOMAD experiment, preprint FTN/AE-95/26, submitted to Nucl. Instr. and Meth.