

RF Stray Currents in SPIDER Power Circuits: Model Assessment and Experimental Results

Marco De Nardi¹, Riccardo Casagrande¹, Alberto Maistrello¹,
Mauro Recchia, Marco Bigi¹, and Loris Zanotto¹

Abstract—The ITER Neutral Beam Test Facility (NBTF), Padua, Italy, hosts two different experiments: Source for Production of Ion of Deuterium Extracted from Rf plasma (SPIDER), the prototype of the ion source (IS) of ITER neutral beam injector (NBI), and Megavolt ITER Injector and Concept Advancement (MITICA), the prototype of the ITER NBI. The ISs of SPIDER and MITICA are driven by radio frequency (RF) power, for a total of 800 kW at 1 MHz. The RF power is delivered to the inductively coupled plasma drivers of the IS by four tetrode oscillators. Operation of SPIDER at high power pointed out the presence of RF stray currents circulating in the electric system. These currents hinder the correct operation of the system, causing damage to its components. To improve the comprehension of the issue, after an overall circuitual investigation and the identification of a possible reclosing path for the RF stray currents, a simplified model of SPIDER electric system was developed, initially focusing on a single RF circuit. The aim of the work presented in this article is to extend the model to four RF circuits, to study the impact of their mutual coupling and of the common potential references on RF stray currents magnitude, with a view to improve the comprehension of the issue and the effect of the provisions to mitigate it. The results obtained with this model are compared to SPIDER experimental measurements for validation.

Index Terms—High-voltage techniques, international thermonuclear experimental reactor (ITER), ion sources, neutral beam test facility (NBTF), oscillators, plasmas, fusion reactors, radio frequency (RF).

I. INTRODUCTION

SPIDER is the full-scale prototype of the negative ion source (IS) of the ITER neutral beam injector (NBI). It is currently in the experimental phase at the Neutral Beam Test Facility (NBTF) hosted in Padua, Italy [1], [2]. During experimental campaigns, the circulation of radio frequency (RF) stray currents in the electrical circuits of Source for Production of Ion of Deuterium Extracted from Rf plasma (SPIDER) was observed. The main evidences of this phenomenon are related to the degradation of the signal-to-noise ratio in diagnostic

Manuscript received 7 February 2022; revised 10 May 2022; accepted 16 June 2022. Date of publication 8 July 2022; date of current version 30 November 2022. This work was supported in part by the International Thermonuclear Experimental Reactor (ITER) Organization, within the framework of the ITER-RFX NBTF agreement; and in part by the European Union via the Euratom Research and Training Program, within the framework of the EUROfusion Consortium under Grant 101052200 EUROfusion. The review of this article was arranged by Senior Editor G. H. Neilson. (Corresponding author: Marco De Nardi.)

The authors are with the Consorzio RFX (CNR, ENEA, INFN, Università di Padova, Acciaierie Venete SpA), 35127 Padua, Italy (e-mail: marco.denardi@igi.cnr.it).

Color versions of one or more figures in this article are available at <https://doi.org/10.1109/TPS.2022.3186291>.

Digital Object Identifier 10.1109/TPS.2022.3186291

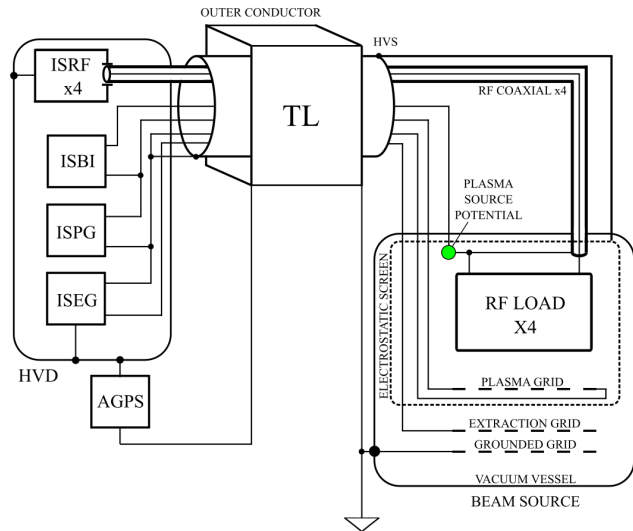

Fig. 1. Simplified scheme of SPIDER electrical circuit, relevant for the study.

devices and to the overheating of passive components not specifically rated to sustain these RF currents [3]. Experimental activities were carried out to understand the origin of this phenomenon [3], [4], and to support the analysis, we developed a simplified circuitual model of SPIDER [5], involving the electrical system components relevant for the study of RF stray currents, that provided a confirmation of the experimental observations from a qualitative point of view and helped in better understanding them. In SPIDER and Megavolt ITER Injector and Concept Advancement (MITICA), it is planned to replace the present tetrode-based RF generators with solid-state amplifiers [6], which implies a modification of the RF system layout. Therefore, obtaining a reliable model capable to reproduce and study the RF stray currents phenomenon is of paramount importance to support the integration of RF solid-state amplifiers in SPIDER and MITICA. Since the existing simplified model is limited to one of the four RF circuits of SPIDER, we extended it to the complete RF system, with the objective of understanding if experimental measurements can be reproduced more accurately. In this article, we analyze how the aspects introduced by the extended model, namely, the mutual coupling between RF circuits and their common potential reference, affect the amplitude and distribution of RF stray currents.

II. OVERVIEW OF SPIDER ELECTRICAL SYSTEM

The electrical system of SPIDER is particularly complex due to the high number of components and connections involved. The simplified scheme relevant for this study

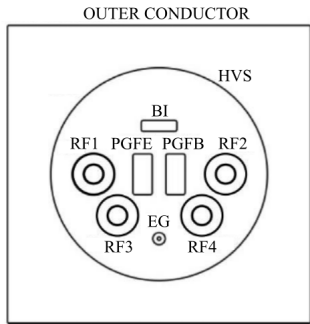

Fig. 2. Cross section of the SPIDER TL relevant for the study.

is depicted in Fig. 1. It can be split into three main parts: the beam source (BS) [7], the high-voltage deck (HVD) [8], and the multiconductor transmission line (TL) [9].

A. Beam Source

The BS, installed inside a vacuum vessel, contains the plasma source, from which negative ions are extracted and accelerated by means of a system of grids. The components relevant for this study are the following.

- 1) Four RF loads, each one consisting of two RF drivers in series, and a capacitive L-type matching network for impedance matching. Each RF driver is an inductively coupled plasma source, consisting of a solenoid wound around an insulating case, in which the plasma is generated [10]. As shown in Fig. 1, the four RF loads are referred to a common potential (plasma source potential). Each RF load represents a sector of the BS.
- 2) Plasma grid (PG) for the production of the filtering magnetic field, used to reduce the number of co-extracted electrons.
- 3) Electrostatic screen (ES), at PG potential, which surrounds the BS in order to provide uniform electric field distribution.
- 4) Extraction grid (EG) for the extraction of the negative ions from the plasma.
- 5) Grounded grid (GG), referred to ground potential, and representing the last stage of the beam acceleration system.

B. High-Voltage Deck

The HVD is an air-insulated Faraday cage referred to the acceleration potential by means of the acceleration grid power supply (AGPS), which is shown in Fig. 1. The HVD contains the IS and extraction power supplies (ISEPSs). The power supplies relevant to this study are the following.

- 1) Four RF generators, named IS RF (ISRF) oscillators, power the RF loads. The ISRF units are based on the self-excited tetrode RF oscillator in push-pull configuration, rated for 200 kW on 50Ω at 1 ± 0.1 MHz.
- 2) Four dc power supplies, used to polarize grids and structures in the BS, or to supply the current for the magnetic filter field. With reference to Fig. 1, the power supplies are named ISBI, ISPG, and ISEG, with IS, and suffices identifying the respective components of the BS they power (with the exception of ISBI, which is the acronym for the bias PS, dedicated to the polarization of the BS).

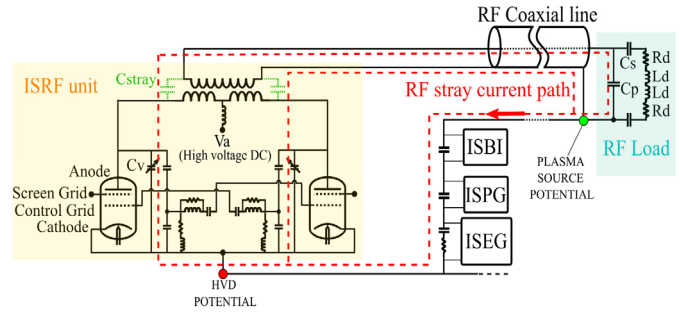

Fig. 3. RF stray currents path (red dashed line) in the current configuration of SPIDER RF system.

C. Multiconductor Transmission Line

The TL is an air-insulated multiconductor TL, which contains all conductors connecting ISEPS and AGPS units to the respective loads in the BS. Fig. 2 shows the cross section of the SPIDER TL: four 31/8" RF coaxial TLs connect the ISRF units to the related loads, while the other dc power supplies are connected to their loads through busbars [bias busbar—BI, PG busbars—Plasma Grid Filter Extraction (PGFE) and Plasma Grid Filter Bias (PGFB)] and cables [EG cable with its screen (EGS)]. All these conductors are contained in the high-voltage screen (HVS) referred to PG potential, which in turn is surrounded by an outer conductor for the minimization of electromagnetic interference. Along the TL, ten equally spaced ferromagnetic cores, namely, the distributed core snubbers (DCSs), are installed around the HVS to limit transients following breakdowns between grids.

III. RF STRAY CURRENTS CIRCULATION

After preliminary tests and analyses on SPIDER, a number of modifications were made to the RF circuits to mitigate RF stray currents [3]. Fig. 3 represents the simplified scheme of the current configuration of SPIDER electrical system (with reference to a single RF circuit), outlining the circulation path of stray currents.

The RF circuits of SPIDER are designed not to affect the operation of the rest of the electric system. In order to ensure the isolation between the reference potential of the RF loads (i.e., plasma source potential) and the ISRF units one (i.e., HVD potential, which is the same of the other non-RF PS), a transformer is installed at the output of the each ISRF unit. However, due to stray elements (stray capacitance between the primary and secondary windings of the RF transformer) and the output filters of the dc power supplies, RF stray currents are allowed to circulate, following the path highlighted in red in Fig. 3. In the previous model, a single RF circuit was considered. Now, the aim is to evaluate whether the mutual coupling between RF loads, their single potential reference, and the coupling between the TL conductors can significantly influence the distribution of the RF stray currents. In order to investigate these aspects, the model has been extended to the four RF circuits of SPIDER. The simplified scheme of the four RF circuits model is depicted in Fig. 4, where the mutual coupling between RF loads and between the four RF coaxial lines, as well as the common potential references is highlighted.

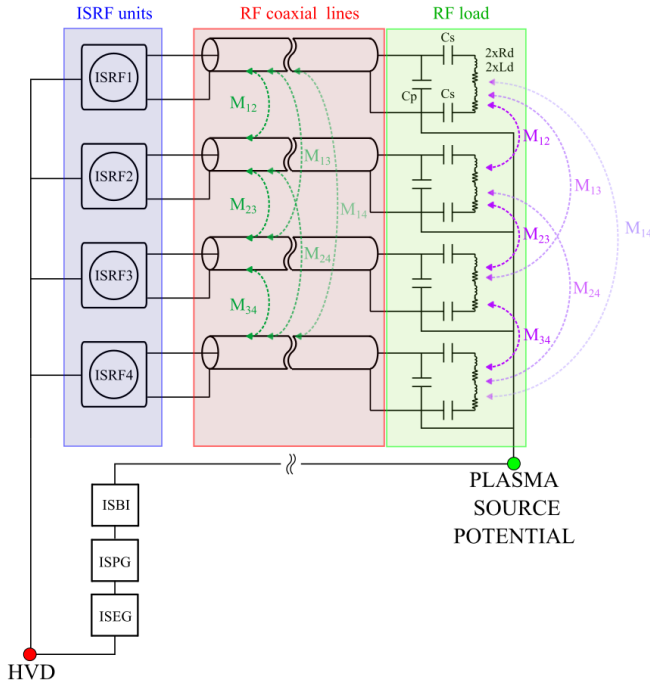

Fig. 4. Simplified scheme of the connections and reference potentials of the four RF circuits model. The mutual coupling among the four RF coaxial lines and the RF loads is highlighted, respectively, in green and purple.

TABLE I
INDUCTIVELY COUPLED PLASMA (ICP) DRIVERS PARAMETERS
(WITHOUT PLASMA) OBTAINED FROM THE RETROFITTING
PROCEDURE AND RF COAXIAL LINES LENGTHS
MEASUREMENTS

	Rd [Ω]	Ld [μH]	L [m]
RF #1	1.91	20.23	46.4
RF #2	1.92	20.24	49.2
RF #3	1.83	19.89	40.7
RF #4	1.85	20.06	45.3

IV. MODEL EXTENSION TO FOUR RF CIRCUITS

The complete scheme of the four RF circuits model, realized with MATLAB Simulink, is shown in Fig. 5. The values of the stray inductances and capacitances inside the BS, computed in [11] through finite element method (FEM) analysis, are the same of the single RF circuit model. Also, the parameters of the output filters of ISBI, ISPG, and ISEG are the same of the single-circuit model. In the extension of the model to the four RF circuits of SPIDER, the following aspects have been modified with respect to the previous model: RF loads and mutual coupling, potential reference, and TL.

A. RF Loads and Mutual Coupling

Due to the size of SPIDER, the connections used to supply the RF loads form significantly large loops (approximately 1 m^2 depending on the specific RF circuit) in the BS. Even though an activity was carried out to minimize these loops [3], a nonnegligible mutual coupling between RF loads is still present. The RF load parameters were extracted from measurements performed with impedance meter and network analyzer at the output of ISRF units. Retrofitting of the impedance measurements allows the evaluation of R_d and L_d (see Table I), while the scattering matrix measurements from the network analyzer are used to retrieve mutual inductances between the four RF loads (see Table II). These parameters

TABLE II
INDUCTANCES MATRIX OF THE INDUCTIVELY COUPLED PLASMA (ICP)
DRIVERS OF THE FOUR RF CIRCUITS

	RF #1	RF #2	RF #3	RF #4
RF #1	20.23 μH	0.05 μH	0.015 μH	0.01 μH
RF #2		20.24 μH	0.03 μH	0.015 μH
RF #3			19.89 μH	0.05 μH
RF #4				20.06 μH

refer to no-load conditions, i.e., without plasma in the RF drivers. The RF coaxial TLs' lengths (see Table I) are derived from the measurement of the time of flight at the output of each ISRF unit.

B. Potential Reference

In the four RF circuits model, it was possible to represent more accurately the actual system, where the four ISRF units are referred to the HVD potential and the four RF loads are referred to the potential of the plasma source.

C. Multiconductor Transmission Line (TL)

With reference to Table I, the length of each of the four ISRF coaxial cables inside the HVD (ISRF TL in Fig. 5) is modeled as a five equivalent- Π cells (no mutual coupling among ISRF TLs inside HVD is considered). SPIDER TL is modeled with ten equivalent- Π cells of 3 m each (30 m in total).

The perunit length parameters were computed with Finite Elements Method Magnetics (FEMM) as in [5]. The model of one cell of the TL is depicted in Fig. 6. The DCSs are modeled as saturable multiwindings transformers.

V. SIMULATIONS

Two different analyses were carried out with the extended model in order to study the effects of mutual couplings between RF loads, the common potential reference, and the coupling in the TL on the RF stray currents. All these analyses were realized in no-plasma conditions. The input parameters required to run the simulations and the description and results of the two analyses are described in the following.

A. Model Inputs

The simulation input parameters are the tetrodes anode and screen grid voltages (V_a , V_{screen}), defining the output power of the ISRF unit and the value of the variable capacitors (C_v), which defines its operating frequency.

B. Mutual Coupling Between RF Loads

Two simulations were carried out to observe the magnitude of the RF stray currents through the ISEG output filter, with and without mutual coupling between RF loads. The figure of merit considered in the analysis is the current on the output filter of ISEG because, in the circuitual scheme, it represents the branch on which all stray currents toward HVD close. Furthermore, it is an easily accessible component for the installation of a current probe. The results of the analysis are shown, respectively, in Fig. 7 and Table III. Fig. 7 represents the fast Fourier transform (FFT) of I_{ISEG} , with and without coupling between the four RF loads. The FFT represents the contributions of the four ISRF units to the stray RF current through ISEG filter. The amplitudes of the four FFTs are different because the four ISRF units operate at different frequencies, output currents and voltages, and on different circuits. The differences between the values obtained from the

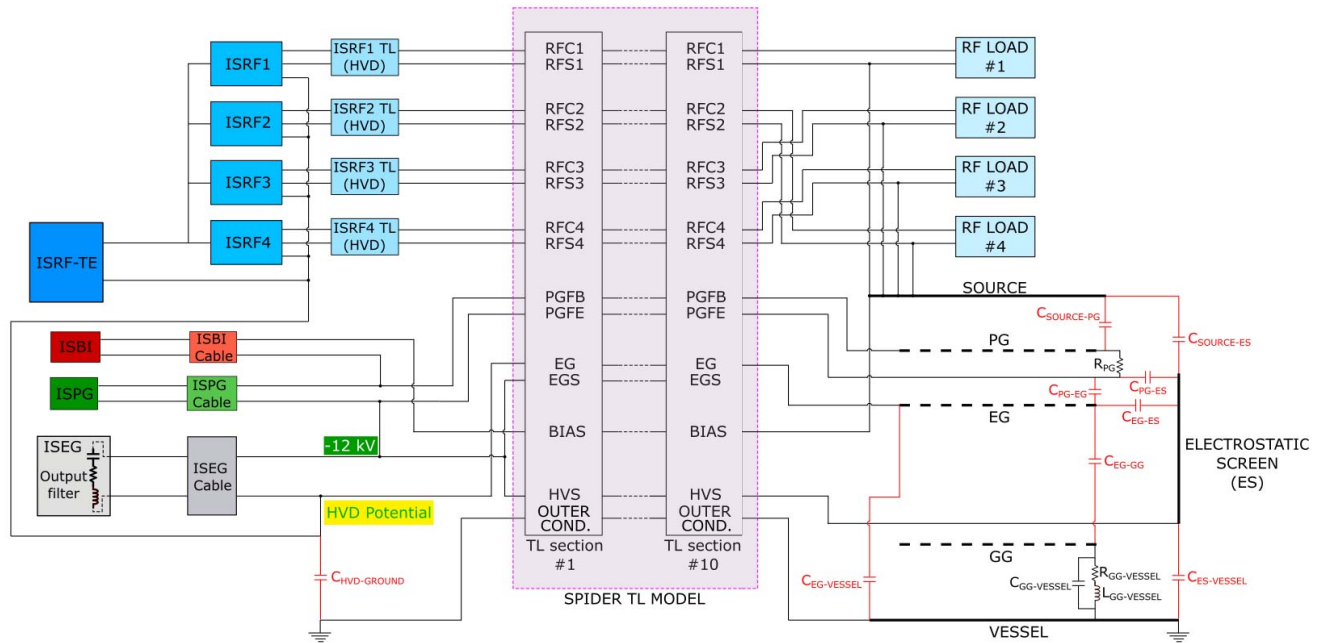

Fig. 5. Complete scheme of the model of the four RF circuits: HVD, TL, and BS. The stray capacitances considered in the model are depicted in red.

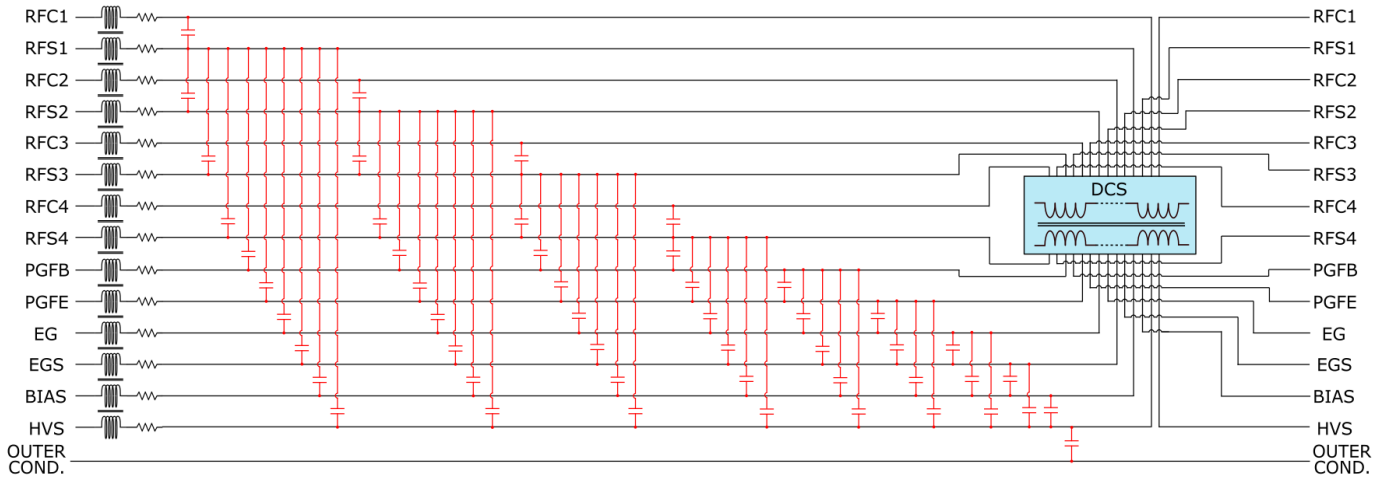

Fig. 6. Model of a single equivalent- Π cell of the SPIDER TL used in the four RF circuits model. The inductive and capacitive coupling between conductors are highlighted.

TABLE III
AMPLITUDE OF I_{ISEG} FFT PEAKS OBTAINED IN THE MUTUAL COUPLING BETWEEN RF LOADS ANALYSIS

	Without coupling		Δ [%]
	With coupling	Without coupling	
	Amplitude of I_{ISEG} FFT peaks [A]		
ISRF #1	0.477	0.469	1.7
ISRF #2	0.514	0.512	0.4
ISRF #3	0.364	0.375	5.6
ISRF #4	0.281	0.282	0.4

TABLE IV
AMPLITUDE OF I_{ISEG} FFT PEAKS OBTAINED IN THE COMMON POTENTIAL REFERENCE AND COUPLING IN THE TL ANALYSIS

	Model with all ISRF units		Δ [%]
	Model with all ISRF units	Model with single ISRF unit	
	Amplitude of I_{ISEG} FFT peaks [A]		
ISRF #1	0.489	0.469	4.3
ISRF #2	0.512	0.472	8.5
ISRF #3	0.375	0.402	6.7
ISRF #4	0.282	0.304	7.2

two simulations are negligible and remain within 6%. As a first approximation, the mutual coupling between RF loads does not introduce significant variations in the amplitude of the RF stray currents.

C. Common Potential Reference and Coupling in the TL

Five simulations were carried out to evaluate the magnitude of RF stray currents through the ISEG output filter. The simulation with four RF circuits (see Fig. 5), without coupling between the RF loads, has been compared to four simulation carried out with the previous model, hence without considering

the common potential reference and the coupling. The four simulations, one for each ISRF unit, were carried out using the same set of simulation inputs and parameters used for the ISRF units in the four RF circuits simulation. This analysis will provide information also regarding the effect of coupling between TL conductors on stray currents. The results of the analysis are shown, respectively, in Fig. 8 and Table IV. In this case, the differences between the amplitudes of I_{ISEG} FFT peaks are within 9%, slightly higher than the analysis in Section V-B. However, no dramatic variations in RF stray

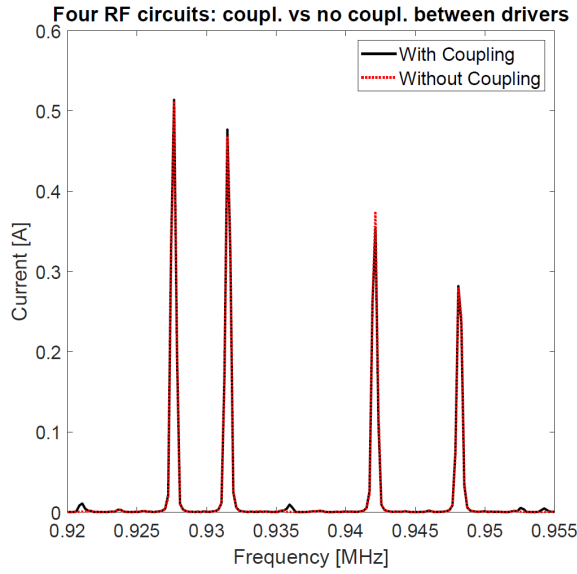

Fig. 7. Effect of mutual coupling between RF loads: focus on I_{ISEG} . The two curves almost completely overlay.

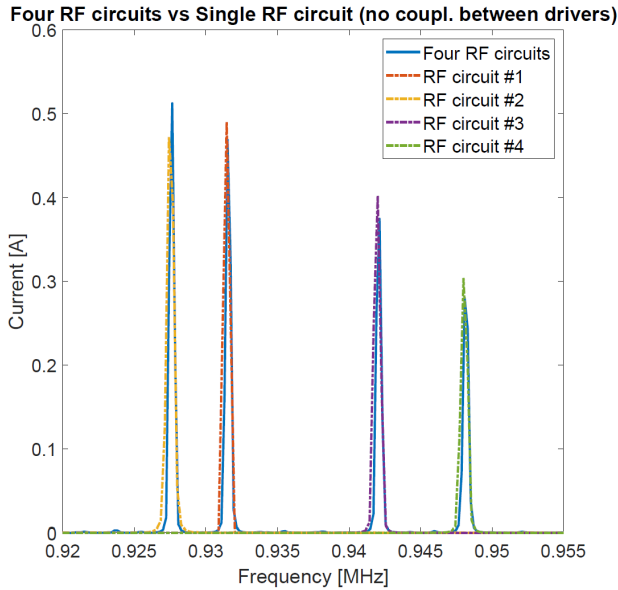

Fig. 8. Effect of common potential reference and coupling in the TL: focus on I_{ISEG} .

currents amplitudes is present, so the effect of the common potential reference of the four RF circuits and the coupling between TL conductors is small.

VI. COMPARISON WITH EXPERIMENTAL MEASUREMENTS

A benchmarking activity has been performed, comparing the simulations results to measurements in SPIDER electrical system (see Figs. 9 and 10). Discrepancies between simulations and measurements are evident: a significant number of variables are involved in the model, and most of them cannot be directly measured. From preliminary tests, it was possible to notice variations in the amplitude of the stray currents, also relevant, by slightly varying some of these parameters. It is therefore necessary to carry out parametric simulations in order to fit experimental results. Due to the complexity of the extended model, the computational time is long, so any simplification is crucial. The results of the analyses of Section V demonstrate that, as a first approximation, it is

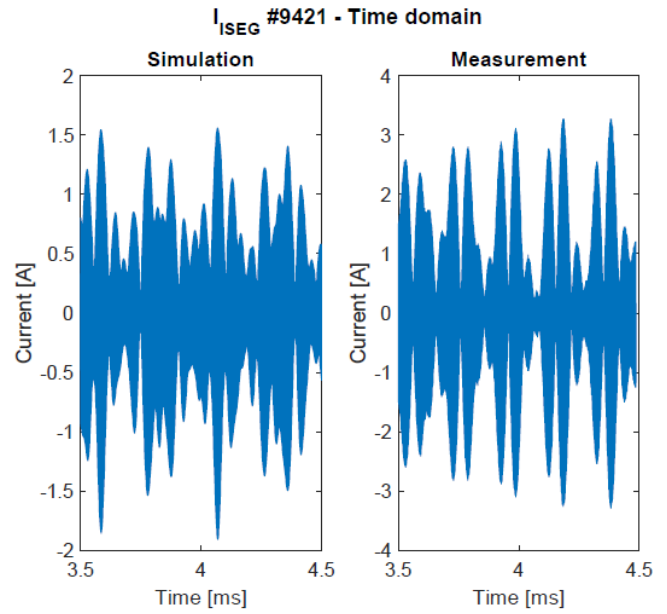

Fig. 9. Comparison between measurement and simulation on I_{ISEG} for reference SPIDER pulse #9421 in time domain.

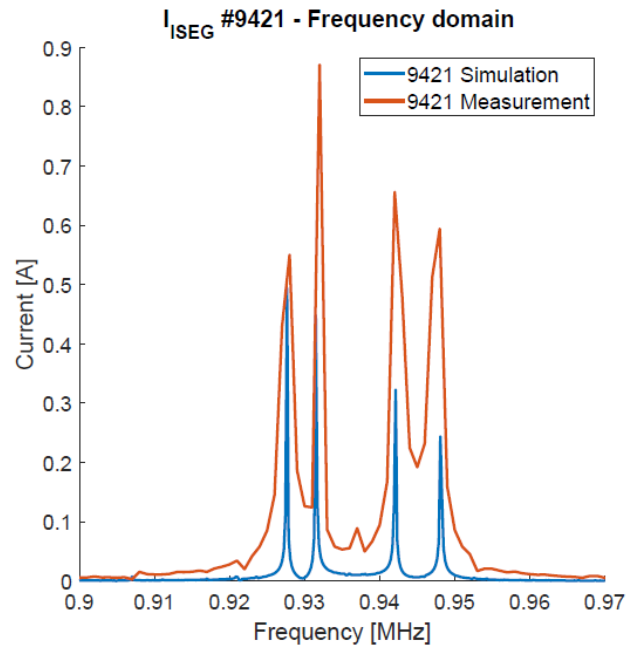

Fig. 10. Comparison between measurement and simulation on I_{ISEG} for reference SPIDER pulse #9421 in frequency domain.

possible to realize these parametric studies with the simplified model, namely, with the single RF circuits.

VII. CONCLUSION AND FUTURE WORKS

The development of the model with the four RF circuits has allowed us to advance in the understanding of the phenomenon of the RF stray currents, in particular regarding the relative weight of the mutual coupling between TL conductors and between RF loads, as well as common potential reference, on their magnitude and circulation. Simulations with the four RF circuits model demonstrate that mutual coupling and common potential reference have small if not negligible effect on the magnitude of the RF stray currents if compared to the single RF circuit model. Furthermore, benchmarking activities

with the extended model outlined the same discrepancies already observed with the single RF circuit model, highlighting that their cause was not related to the coupling effects. These results prove that the simplified model is sufficient to obtain a good representation of the phenomenon, thus limiting computational time to tens of seconds, against the tens of minutes required to run the model with four RF circuits. This will be beneficial in view of the integration of the solid-state amplifiers in the RF system of SPIDER and MITICA that requires evaluating the RF stray currents and identifying mitigating provisions.

ACKNOWLEDGMENT

The views and opinions expressed herein do not necessarily reflect those of the ITER Organization. Views and opinions expressed are however those of the author(s) only and do not necessarily reflect those of the European Union or the European Commission. Neither the European Union nor the European Commission can be held responsible for them.

REFERENCES

- [1] G. Serianni *et al.*, "First operation in SPIDER and the path to complete MITICA," *Rev. Sci. Instrum.*, vol. 91, Feb. 2020, Art. no. 023510.
- [2] V. Toigo *et al.*, "On the road to ITER NBIs: SPIDER improvement after first operation and MITICA construction progress," *Fusion Eng. Des.*, vol. 168, Jul. 2021, Art. no. 112622.
- [3] A. Maistrello *et al.*, "Improvements in the SPIDER RF system," *Fusion Eng. Des.*, vol. 167, Jun. 2021, Art. no. 112337.
- [4] A. Zamengo, M. Bigi, A. Maistrello, and M. Recchia, "Power supply system for large negative ion sources: Early operation experience on the SPIDER experiment," *Fusion Eng. Des.*, vol. 173, Dec. 2021, Art. no. 112790.
- [5] R. Casagrande, A. Maistrello, M. De Nardi, M. Dan, and M. Recchia, "Study of RF stray currents in ITER neutral beam test facilities," *Appl. Sci.*, vol. 11, no. 23, p. 11126, Nov. 2021.
- [6] L. Zanutto *et al.*, "Radio frequency generators based on solid state amplifiers for the NBTF and ITER projects," *IEEE Trans. Plasma Sci.*, early access, Jun. 10, 2022, doi: [10.1109/TPS.2022.3176030](https://doi.org/10.1109/TPS.2022.3176030).
- [7] D. Marcuzzi *et al.*, "Detail design of the beam source for the SPIDER experiment," *Fusion Eng. Des.*, vol. 85, nos. 10–12, pp. 1792–1797, Dec. 2010.
- [8] M. Bigi *et al.*, "Design, manufacture and factory testing of the ion source and extraction power supplies for the SPIDER experiment," *Fusion Eng. Des.*, vols. 96–97, pp. 405–410, Oct. 2015.
- [9] M. Boldrin *et al.*, "The transmission line for the SPIDER experiment: From design to installation," *Fusion Eng. Des.*, vol. 123, pp. 247–252, Nov. 2017.
- [10] D. Marcuzzi, P. Agostinetti, M. D. Palma, H. D. Falter, B. Heinemann, and R. Riedl, "Design of the RF ion source for the ITER NBI," *Fusion Eng. Des.*, vol. 82, nos. 5–14, pp. 798–805, Oct. 2007.
- [11] A. Pesce and A. Zamengo, "SPIDER integrated modelling report," Tech. Rep., RFX_SPIDER_TN_240, Dec. 2012.



Marco De Nardi was born in 1995. He received the master's degree in electrical engineering from the University of Padua, Padua, Italy, in 2021. He is currently pursuing the Ph.D. degree in fusion science and engineering with Consorzio RFX, Padua, in the framework of the Joint Ph.D. programme coordinated by the University of Padua and University of Napoli, Naples, Italy.

His research interests are mainly in the field of electron cyclotron resonance heating (ECRH) power supply systems, radio frequency (RF) generators for ion sources of neutral beam injector (NBI), and vacuum circuit breakers for the interruption of high dc currents in fusion experiments.



research mainly focuses

Riccardo Casagrande was born in 1991. He received the master's degree (Hons.) in electrical engineering from the University of Padua, Padua, Italy, in 2017. He is currently pursuing the Ph.D. degree in fusion science and engineering in the framework of the Joint Ph.D. programme coordinated by Ghent University, Ghent, Belgium, and University of Padua.

Since 2020, he holds a EUROfusion secondment contract as a Power Supplies Engineer at the ITER Neutral Beam Test Facility (NBTF), Padua. His research mainly focuses on radio frequency power supplies for NBI systems.



interruption, switching neutral beam injectors.

Alberto Maistrello was born in 1984. He received the master's degree in electric engineering from the University of Padua, Padua, Italy, in 2009, and the Ph.D. degree in fusion science and engineering from the Università degli studi di Padova, Padua, and Universidade de Lisboa, Lisbon, Portugal, in 2018.

He is a Researcher with Consorzio RFX, Padua, working in the field of power supply systems for thermonuclear fusion experiments. His field of research focuses on power quality in high voltage (HV) and medium voltage (MV) grids, dc current converters, and radio frequency (RF) systems for



Mauro Recchia received the master's degree in electronic engineering and the Ph.D. degree in electrical engineering from the University of Padua, Padua, Italy, in 2004 and 2009, respectively.

He is currently a Researcher with the Power System Group, Consorzio RFX, Padua. His fields of research include high-power switching converters for fusion experiments, modeling of electrical circuits for fast transient studies, and modeling of high-power radio frequency circuits for inductively coupled plasma sources.



Marco Bigi received the master's degree in electrical engineering from the Politecnico di Milano, Milan, Italy, in 1997, and the Ph.D. degree in "applied electromagnetism in electrical and biomedical engineering, electronics, smart sensors, and nanotechnologies" from the University of Pisa, Pisa, Italy, in 2008.

From 1998 to 2004, he was with the magnet and additional heating power supply team at the Joint European Torus, Culham, U.K. In 2005, he joined Consorzio RFX, Padua, Italy, working on the power supplies of the test facility for the neutral beam system of the ITER project.



Loris Zanutto was born in 1974. He received the master's degree (Hons.) in electrical engineering and the Ph.D. degree from the University of Padua, Padua, Italy, in 1999 and 2002, respectively, and working on very high power inverters for thermonuclear fusion experiments.

Since 2002, he has been with Consorzio RFX, Padua, as a Research Engineer. Since 2018, he has been a Project Leader of the Power Supply systems of the Neutral Beam Test Facility, Padua. He has more than 20 years of experience on power supplies for fusion facilities. His research interests are mainly in the field of power supply plants based on ac/dc and dc/dc converters and on power supply for neutral beam injection for fusion experiments. He is also interested in power quality problems.