

RECEIVED: July 30, 2020

REVISED: September 3, 2020

ACCEPTED: September 30, 2020

PUBLISHED: November 18, 2020

# Axion quality from the (anti)symmetric of $SU(\mathcal{N})$

Marco Ardu,<sup>a</sup> Luca Di Luzio,<sup>b</sup> Giacomo Landini,<sup>a,c</sup> Alessandro Strumia,<sup>a</sup>  
 Daniele Teresi<sup>a,c</sup> and Jin-Wei Wang<sup>a,d,e</sup>

<sup>a</sup>*Dipartimento di Fisica “E. Fermi”, Università di Pisa,  
 Largo Bruno Pontecorvo 3, Pisa I-56127, Italy*

<sup>b</sup>*DESY, Notkestraße 85, Hamburg D-22607, Germany*

<sup>c</sup>*INFN, Sezione di Pisa, Largo Bruno Pontecorvo 3, Pisa I-56127, Italy*

<sup>d</sup>*Key Laboratory of Particle Astrophysics, Institute of High Energy Physics,  
 Chinese Academy of Sciences, Beijing 100049, China*

<sup>e</sup>*School of Physical Sciences, University of Chinese Academy of Sciences,  
 Beijing 100049, China*

*E-mail:* [marco.ardu@umontpellier.fr](mailto:marco.ardu@umontpellier.fr), [luca.diluzio@desy.de](mailto:luca.diluzio@desy.de),  
[giacomo.landini@phd.unipi.it](mailto:giacomo.landini@phd.unipi.it), [astrumia@df.unipi.it](mailto:astrumia@df.unipi.it),  
[daniele.teresi@cern.ch](mailto:daniele.teresi@cern.ch), [wangjinwei@ihep.ac.cn](mailto:wangjinwei@ihep.ac.cn)

**ABSTRACT:** We propose two models where a U(1) Peccei-Quinn global symmetry arises accidentally and is respected up to high-dimensional operators, so that the axion solution to the strong CP problem is successful even in the presence of Planck-suppressed operators. One model is  $SU(\mathcal{N})$  gauge interactions with fermions in the fundamental and a scalar in the symmetric. The axion arises from spontaneous symmetry breaking to  $SO(\mathcal{N})$ , that confines at a lower energy scale. Axion quality in the model needs  $\mathcal{N} \gtrsim 10$ . SO bound states and possibly monopoles provide extra Dark Matter candidates beyond the axion. In the second model the scalar is in the anti-symmetric:  $SU(\mathcal{N})$  broken to  $Sp(\mathcal{N})$  needs even  $\mathcal{N} \gtrsim 20$ . The cosmological DM abundance, consisting of axions and/or super-heavy relics, can be reproduced if the PQ symmetry is broken before inflation (Boltzmann-suppressed production of super-heavy relics) or after (super-heavy relics in thermal equilibrium get partially diluted by dark glue-ball decays).

**KEYWORDS:** Beyond Standard Model, Cosmology of Theories beyond the SM, Global Symmetries

ARXIV EPRINT: [2007.12663](https://arxiv.org/abs/2007.12663)

---

## Contents

<b>1</b>	<b>Introduction</b>	<b>1</b>
<b>2</b>	<b>Outline of the models</b>	<b>3</b>
<b>3</b>	<b>Antisymmetric scalar that breaks <math>SU(\mathcal{N}) \rightarrow Sp(\mathcal{N})</math></b>	<b>4</b>
3.1	Symmetry breaking and perturbative spectrum	5
3.2	Confinement and bound states	6
3.3	Axion effective Lagrangian	6
3.4	Higher dimensional operators	7
3.5	Cosmology and Dark Matter	10
3.5.1	PQ broken before inflation, $T_{RH} \lesssim f_a$	10
3.5.2	PQ broken after inflation, $T_{RH} \gtrsim f_a$	11
<b>4</b>	<b>Symmetric scalar that breaks <math>SU(\mathcal{N}) \rightarrow SO(\mathcal{N})</math></b>	<b>14</b>
4.1	Symmetry breaking and perturbative spectrum	15
4.2	Confinement and bound states	15
4.3	Higher dimensional operators	16
4.4	$SU(\mathcal{N})/SO(\mathcal{N})$ monopoles?	17
4.5	Cosmology and Dark Matter	17
4.5.1	PQ broken before inflation, $T_{RH} \lesssim f_a$	18
4.5.2	PQ broken after inflation, $T_{RH} \gtrsim f_a$	18
<b>5</b>	<b>Conclusions</b>	<b>19</b>

---

## 1 Introduction

The Peccei-Quinn (PQ) solution to the strong CP problem [1, 2] has a problematic aspect: it relies on a global  $U(1)_{PQ}$  symmetry which, although broken at low energy by the QCD anomaly, must be an extremely good symmetry of high-energy physics. This issue is known as the *PQ quality problem* [3–8]. Global symmetries are believed not to be fundamental, and arise as accidental symmetries e.g. in gauge theories. Well known examples are baryon and lepton numbers in the Standard Model (SM). Conceptually, there are two steps in the formulation of the problem:

- i)* the  $U(1)_{PQ}$  should arise accidentally in a renormalizable Lagrangian;
- ii)* approximating higher-energy physics as non-renormalizable operators suppressed by some scale  $\Lambda_{UV}$ , the  $U(1)_{PQ}$  should be preserved by operators with dimension up to  $d \sim 9$  assuming  $\Lambda_{UV} \sim M_{Pl}$  and an axion decay constant  $f_a \gtrsim 10^9$  GeV.

The bound becomes stronger for higher  $f_a$  and lower  $\Lambda_{UV}$ . Indeed, it comes from requiring that the energy density due to UV sources of  $U(1)_{PQ}$  breaking is about  $10^{-10}$  times smaller than the energy density of the QCD axion potential

$$\left(\frac{f_a}{\Lambda_{UV}}\right)^{d-4} f_a^4 \lesssim 10^{-10} \Lambda_{QCD}^4, \tag{1.1}$$

so that the induced axion vacuum expectation value (VEV) is  $\langle a \rangle / f_a \lesssim 10^{-10}$ , within the neutron electric dipole moment bound.

In string models one expects towers of new states below or around the Planck scale, potentially generating PQ-breaking higher-dimensional operators, that make manifest the PQ-quality problem. Furthermore, it is believed that gravity violates global symmetries, based on semi-classical arguments related to black holes and Hawking radiation. In scenarios in which Einstein gravity is minimally coupled to the axion field, non-conservation of the PQ global charge arises from non-perturbative effects described by Euclidean wormholes. These effects are calculable to some extent and correct the axion potential as [9–13, 54]

$$\sim M_{Pl}^4 e^{-S_{wh}} \cos(a + \delta), \tag{1.2}$$

where  $\delta \sim 1$  is a generic displacement due to the fact that the gravity contribution does not need to be aligned to the low-energy QCD contribution. Computing the wormhole action taking into account the axion only gives  $S_{wh} \sim N M_{Pl} / f_a$ , so that the contribution in eq. (1.2) poses a problem for the PQ solution if  $f_a / N \gtrsim 6 \cdot 10^{16}$  GeV, where the integer  $N$  is the minimal PQ charge carried by the wormhole. In theories where  $f_a$  is the vacuum expectation value of some sub-Planckian field, this grows reaching the Planck scale in the wormhole throat, giving a reduced  $S_{wh} \sim N \ln M_{Pl} / f_a$  [11]. According to [9, 11, 54] this is equivalent to local operators with an extra suppression  $e^{-S_{wh}} \sim (f_a / M_{Pl})^N$  with respect to the generic Planck-suppressed operators considered in this paper.

Eq. (1.2) holds if gravity is well described by the Einstein term at Planckian energies. An alternative possibility is that gravity gets modified at lower energies where it is still weakly coupled so that it remains weakly coupled, making non-perturbative effects irrelevant. This for example arises in 4-derivative gravity, a renormalizable theory that allows for accidental global symmetries not broken by higher dimensional operators and negligibly broken by non-perturbative gravitational effects [14]. Such theory, however, contains potentially problematic negative kinetic energy at the classical level (see e.g. [15]).

We here assume that the PQ-quality problem is a real problem and address it by devising a simple gauge dynamics along the lines of [16, 17] that gives an accidental global PQ symmetry respected by operators up to large enough dimension. Different approaches to the PQ quality problem, but also based on non-abelian gauge dynamics, have been discussed in [18–23]. Section 3 describes a model based on a gauge group  $SU(\mathcal{N})$  spontaneously broken to  $Sp(\mathcal{N})$  by a scalar  $\mathcal{S}$  in the anti-symmetric representation in the presence of fermions in the fundamental, as listed in table 1. The PQ symmetry is broken by the  $\mathcal{N}/2$ -dimensional local operator  $\sqrt{\det \mathcal{S}}$ . Section 4 considers a similar model where a scalar  $\mathcal{S}$  in the symmetric breaks  $SU(\mathcal{N}) \rightarrow SO(\mathcal{N})$ , and the first PQ-breaking operator is the

Field name	Lorentz spin	Gauge symmetries				Global accidental symmetries		
		$U(1)_Y$	$SU(2)_L$	$SU(3)_c$	$SU(\mathcal{N})$	$U(1)_{PQ}$	$U(1)_Q$	$U(1)_\mathcal{L}$
$\mathcal{S}$	0	0	1	1	$\mathcal{N}\mathcal{N}$	+1	0	0
$\mathcal{Q}_L$	1/2	$+Y_Q$	1	3	$\mathcal{N}$	+1/2	+1	0
$\mathcal{Q}_R$	1/2	$-Y_Q$	1	$\bar{3}$	$\mathcal{N}$	+1/2	-1	0
$\mathcal{L}_L^{1,2,3}$	1/2	$+Y_\mathcal{L}$	1	1	$\bar{\mathcal{N}}$	-1/2	0	+1
$\mathcal{L}_R^{1,2,3}$	1/2	$-Y_\mathcal{L}$	1	1	$\bar{\mathcal{N}}$	-1/2	0	-1

**Table 1.** Field content of the model. The scalar  $\mathcal{S}$  can be in the anti-symmetric (section 3) or in the symmetric (section 4) two-index representation. The heavy quarks  $\mathcal{Q}_L, \mathcal{Q}_R$  and leptons  $\mathcal{L}_L, \mathcal{L}_R$  are Weyl doublets. If  $\mathcal{L}$  have vanishing hypercharge, their bound states could become acceptable DM candidates and there is no difference between  $\mathcal{L}_L$  and  $\mathcal{L}_R$ .

$\mathcal{N}$ -dimensional operator  $\det \mathcal{S}$ . Both models can provide extra Dark Matter (DM) candidates beyond the axion. Section 2 outlines some common features of the two models. Section 3 describes the model with a scalar in the anti-symmetric, and section 4 the model with a scalar in the symmetric. Conclusions are given in section 5.

## 2 Outline of the models

We consider a gauge group  $G_{SM} \otimes SU(\mathcal{N})$ , with a new scalar  $\mathcal{S}$  in the two-index symmetric or anti-symmetric representation of  $SU(\mathcal{N})$ , and new left-handed chiral Weyl fermions charged under  $SU(\mathcal{N})$  as listed in table 1: one  $\mathcal{Q}$  dubbed ‘quark’ because in the fundamental of color, and three  $\mathcal{L}$  dubbed ‘leptons’ because uncolored.<sup>1</sup> Three  $\mathcal{L}$  are needed in order to avoid gauge anomalies and to obtain the desired PQ anomalies. The three  $\mathcal{L}$  could be  $1 \oplus 2$  or  $1 \oplus 1 \oplus 1$  under  $SU(2)_L$ ; as the choice does not make a big difference we assume the latter possibility and that all 3 leptons have the same hypercharge  $Y_\mathcal{L}$ , for the moment left unspecified and possibly vanishing. Irrespectively of their hypercharges, the fermions  $\mathcal{Q}$  and  $\mathcal{L}$  are chiral: their mass terms are forbidden by gauge invariance for all values of the hypercharges  $Y_Q$  and  $Y_\mathcal{L}$ .

As discussed in the next sections, the renormalizable theory contains three accidental global  $U(1)$  symmetries: the one acting as a phase rotation of the scalar  $\mathcal{S}$  will be the PQ symmetry. It gets spontaneously broken by the vacuum expectation value of the scalar  $\mathcal{S}$ , that also breaks  $SU(\mathcal{N})$  to either  $Sp(\mathcal{N})$  (scalar in the anti-symmetric, studied in section 3) or to  $SO(\mathcal{N})$  (scalar in the symmetric, studied in section 4). As a result the fermions  $\mathcal{Q}$  and  $\mathcal{L}$  acquire mass from Yukawa couplings to  $\mathcal{S}$  and the phase of  $\mathcal{S}$  becomes the axion. As  $\mathcal{N} = \bar{\mathcal{N}}$  for  $SO(\mathcal{N})$  and  $Sp(\mathcal{N})$ , their condensation at lower energy preserves

<sup>1</sup>The fermion content shares some similarities with some of the composite accidental axion models of [20]. The main qualitative difference is that there their  $\mathcal{L}$  form a triplet under an extra  $SU(3)$  and QCD is the vectorial subgroup of the two  $SU(3)$  factors. This gives a different anomaly structure such that only in our case large  $\mathcal{N}$  leads to PQ quality.

SM gauge symmetries. In both models all gauge anomalies vanish, and  $U(1)_{PQ}$  has the desired anomalies:

- There is a non-vanishing  $U(1)_{PQ} SU(3)_c^2$  anomaly: to achieve this we introduced the fermions  $\mathcal{L}$  and  $\mathcal{Q}$  in two different representations of color. We chose the simplest ones (singlet and triplet), although different models using more complicated representations of color are possible.
- The  $U(1)_{PQ} U(1)_Y^2$  anomaly is proportional to  $Y_{\mathcal{Q}}^2 - Y_{\mathcal{L}}^2$  and contributes to the axion-photon coupling.
- We introduced the appropriate number of leptons  $\mathcal{L}$  such that the  $U(1)_{PQ} SU(\mathcal{N})^2$  anomaly vanishes: then the axion relaxes the  $SU(3)_c \theta$  term, rather than the one of the extra gauge group  $SU(\mathcal{N})$ .

A similar model based on  $SU(\mathcal{N})_L \times SU(\mathcal{N})_R$  gauge dynamics broken by a scalar transforming in the bi-fundamental down to  $SU(\mathcal{N})_{L+R}$  was considered in [16] (see also [24–26]), which shares similarities with the two models presented here. Differently from [16], we assign non-zero SM hypercharges to the exotic fermions and show that it is possible to get rid of dangerous colored relics. This enlarges the parameter space of the model also to the case where the PQ is broken after inflation and opens the possibility of having extra DM candidates in the form of Sp/SO bound states.

### 3 Antisymmetric scalar that breaks $SU(\mathcal{N}) \rightarrow Sp(\mathcal{N})$

We assume even  $\mathcal{N}$ , as for odd  $\mathcal{N}$  symmetry breaking is slightly different and the axion is eaten by a vector [17]. If  $\mathcal{N} > 8$  the most generic renormalizable Lagrangian is

$$\mathcal{L} = \mathcal{L}_{SM} + \mathcal{L}_{kin} + \mathcal{L}_{Yuk} - V(\mathcal{S}). \quad (3.1)$$

Using Weyl two-component spinors

$$\mathcal{L}_{kin} = -\frac{1}{4} \mathcal{G}^{A\mu\nu} \mathcal{G}_{\mu\nu}^A + \text{Tr}(\mathcal{D}_\mu \mathcal{S})(\mathcal{D}^\mu \mathcal{S})^\dagger + \sum_{f=\mathcal{Q}_{L,R}, \mathcal{L}_{L,R}} \bar{f} i D_\mu \sigma^\mu f \quad (3.2a)$$

$$-\mathcal{L}_{Yuk} = \begin{cases} y_{\mathcal{Q}} \mathcal{Q}_L \mathcal{S}^* \mathcal{Q}_R + y_{\mathcal{L}}^{ij} \mathcal{L}_L^i \mathcal{S} \mathcal{L}_R^j + \text{h.c.} & \text{if } Y_{\mathcal{L}} \neq 0 \\ y_{\mathcal{Q}} \mathcal{Q}_L \mathcal{S}^* \mathcal{Q}_R + y_{\mathcal{L}}^{ii'} \mathcal{L}_L^i \mathcal{S} \mathcal{L}_R^{i'} / 2 + \text{h.c.} & \text{if } Y_{\mathcal{L}} = 0 \end{cases} \quad (3.2b)$$

$$V(\mathcal{S}) = M_S^2 \text{Tr}(\mathcal{S} \mathcal{S}^\dagger) + \lambda_S \text{Tr}(\mathcal{S} \mathcal{S}^\dagger)^2 + \lambda'_S \text{Tr}(\mathcal{S} \mathcal{S}^\dagger \mathcal{S} \mathcal{S}^\dagger) - \lambda_{HS} (H^\dagger H) \text{Tr}(\mathcal{S} \mathcal{S}^\dagger), \quad (3.2c)$$

where  $H$  is the SM Higgs doublet. If  $Y_{\mathcal{L}} \neq 0$  without loss of generality we can rotate to a basis where the Yukawa matrix  $y_{\mathcal{L}}$  is diagonal,  $\text{diag}(y_{\mathcal{L}_1}, y_{\mathcal{L}_2}, y_{\mathcal{L}_3})$ , with real positive entries. If  $Y_{\mathcal{L}} = 0$  the matrix  $y_{\mathcal{L}}$  is anti-symmetric and can be rotated to  $\text{diag}(y_{\mathcal{L}_1}, y_{\mathcal{L}_2}, y_{\mathcal{L}_3}) \otimes \epsilon$  where  $\epsilon$  is the  $2 \times 2$  antisymmetric Levi-Civita tensor.

**Accidental symmetries.** The gauge-covariant kinetic terms are invariant under phase rotations of each field. In the presence of the Yukawa and potential couplings the theory remains accidentally invariant under

$$U(1)_{\mathcal{Q}} \otimes U(1)_{\mathcal{L}_{1,2,3}} \otimes U(1)_{\text{PQ}} \tag{3.3}$$

where  $U(1)_{\mathcal{Q}}$  and  $U(1)_{\mathcal{L}_i}$  are the baryon and lepton numbers of  $\mathcal{Q}$  and  $\mathcal{L}_i$  according to which  $\mathcal{Q}_L$  and  $\mathcal{Q}_R$  have the opposite charge (similarly for leptons), while  $\mathcal{S}$  is uncharged. The  $U(1)_{\text{PQ}}$  symmetry acting on  $\mathcal{S}$  can be identified (a posteriori) as a PQ symmetry and it acts as shown in table 1, where we chose a convenient basis. The accidental flavour symmetry rotates with opposite phases the two  $\mathcal{L}$  fields involved in each mass term: for  $Y_{\mathcal{L}} \neq 0$  mass terms involve  $\mathcal{L}_L \mathcal{L}_R$  pairs, while for  $Y_{\mathcal{L}} = 0$  a similar pair structure arises at renormalizable level thanks to the anti-symmetry of the mass matrix.

**Landau poles.** We constrain the field content and parameters of the model by requiring that its couplings do not hit Landau poles below the Planck scale. The  $SU(\mathcal{N})$  gauge coupling  $\mathfrak{g}$  is asymptotically free. Above the masses  $m_{\mathcal{Q}}, m_{\mathcal{L}}$  of the new fermions, the one-loop beta functions of the strong and hypercharge gauge coupling  $g_1^2 = 5g_Y^2/3$  are

$$\frac{dg_3^2}{d \ln \mu^2} = \frac{g_3^4}{(4\pi)^2} \left( -7 + \frac{2}{3} \mathcal{N} \right), \quad \frac{dg_1^2}{d \ln \mu^2} = \frac{g_1^4}{(4\pi)^2} \left( \frac{41}{10} + \frac{12\mathcal{N}}{5} (Y_{\mathcal{L}}^2 + Y_{\mathcal{Q}}^2) \right). \tag{3.4}$$

Assuming  $m_{\mathcal{Q}} \sim m_{\mathcal{L}} \sim 10^{11} \text{GeV}$ , sub-Planckian Landau poles in  $g_3$  and  $g_Y$  are avoided if  $\mathcal{N} \lesssim 30$  and  $\mathcal{N}(Y_{\mathcal{Q}}^2 + Y_{\mathcal{L}}^2) \lesssim 4$ .

### 3.1 Symmetry breaking and perturbative spectrum

In a range of potential parameters, the scalar  $\mathcal{S}$  acquires vacuum expectation value  $\langle \mathcal{S} \rangle = w\gamma_{\mathcal{N}}$  where  $\gamma_{\mathcal{N}} = \mathbb{1}_{\mathcal{N}/2} \otimes \epsilon$  is the invariant tensor under symplectic transformations. This breaks  $SU(\mathcal{N}) \otimes U(1)_{\text{PQ}}$  to  $\text{Sp}(\mathcal{N})$  leaving one axion and giving mass to all new fermions. Following [17] for even  $\mathcal{N}$  the scalar field is conveniently parametrised as

$$\mathcal{S} = \left[ \left( w + \frac{s}{\sqrt{\mathcal{N}/2}} \right) \gamma_{\mathcal{N}} + 2(\tilde{s}^b + i\tilde{a}^b) \tilde{T}^b \gamma_{\mathcal{N}} \right] e^{\frac{ia}{\sqrt{\mathcal{N}/2}w}}, \tag{3.5}$$

where  $\tilde{T}^b$  are the  $SU(\mathcal{N})$  generators such that  $\gamma_{\mathcal{N}} \tilde{T}^b$  is anti-symmetric (which satisfy the condition  $\tilde{T}^{b*} = -\gamma_{\mathcal{N}} \tilde{T}^b \gamma_{\mathcal{N}}$  and corresponds to the broken generators). The mass spectrum at perturbative level is:

- $\mathcal{N}(\mathcal{N} + 1)/2$  massless vectors  $\mathcal{A}^a$  in the adjoint of  $\text{Sp}(\mathcal{N})$ ;
- $\mathcal{N}(\mathcal{N} - 1)/2 - 1$  vectors  $\mathcal{W}^b$  in the traceless anti-symmetric of  $\text{Sp}(\mathcal{N})$ , that acquire a squared mass  $M_{\mathcal{W}}^2 = \mathfrak{g}^2 w^2$  eating the Goldstone bosons  $\tilde{a}^b$ ;
- The massless scalar  $a$ , singlet under  $\text{Sp}(\mathcal{N})$ . In view of the  $U(1)_{\text{PQ}} SU(3)_c^2$  anomaly it can be called axion and, as shown below, its decay constant will be  $f_a = w/\sqrt{2\mathcal{N}}$ . The axion will get a mass because of the QCD anomaly;

- The scalar  $s$  singlet under  $\text{Sp}(\mathcal{N})$ . If symmetry breaking arises through the Coleman-Weinberg mechanism it is light with squared mass  $M_s^2 = 24(\mathcal{N}\lambda_S + \lambda'_S)w^2$ ;
- $\mathcal{N}(\mathcal{N}-1)/2 - 1$  scalars  $\tilde{s}^b$  with squared mass  $M_{\tilde{s}}^2 = 8(\mathcal{N}\lambda_S + 3\lambda'_S)w^2$ , in the traceless anti-symmetric of  $\text{Sp}(\mathcal{N})$ ;
- One colored Dirac quark  $\Psi_Q = (\gamma_{\mathcal{N}}\mathcal{Q}_L, \bar{\mathcal{Q}}_R)^T$  with mass  $M_Q = y_Q w$  in the anti-fundamental of  $\text{Sp}(\mathcal{N})$  charged under the accidental global  $U(1)_Q$ ;
- Three Dirac leptons with masses  $M_{\mathcal{L}^i} = y_{\mathcal{L}^i} w$  in the fundamental of  $\text{Sp}(\mathcal{N})$  and charged under the accidental global  $U(1)_{\mathcal{L}^i}$ . Dirac fermions are constructed pairing the Weyl fermions involved in each mass term e.g.  $\Psi_{\mathcal{L}^i} = (\gamma_{\mathcal{N}}\mathcal{L}^i_L, \bar{\mathcal{L}}^i_R)$  if  $Y_{\mathcal{L}^i} \neq 0$ .

The fermions are perturbatively stable thanks to the unbroken global  $U(1)_{Q,\mathcal{L}^i}$  symmetries discussed in eq. (3.3).

### 3.2 Confinement and bound states

The  $\text{Sp}(\mathcal{N})$  gauge dynamics confines at the energy scale

$$\Lambda_{\text{Sp}} = f_a \exp \left[ -\frac{12\pi}{11(\mathcal{N}+2)\alpha_{\text{DC}}(f_a)} \right], \quad (3.6)$$

where  $\alpha_{\text{DC}} = \mathfrak{g}^2/4\pi$  and we took into account only the running due to the gauge bosons  $\mathcal{A}$ . We normalise the Dynkin index of  $\text{SU}(\mathcal{N})$  as  $S_2 = 1/2$  for the fundamental. In the confined phase, the baryons containing fermions ( $\epsilon_{\mathcal{N}}\mathcal{W}^{(\mathcal{N}-2)/2}\mathcal{Q}\mathcal{Q}$ ,  $\epsilon_{\mathcal{N}}\mathcal{W}^{(\mathcal{N}-2)/2}\mathcal{L}\mathcal{L}$  and  $\epsilon_{\mathcal{N}}\mathcal{W}^{(\mathcal{N}-2)/2}\mathcal{Q}\mathcal{L}$ , with  $\epsilon_{\mathcal{N}}$  denoting the  $\mathcal{N}$ -dimensional Levi-Civita tensor) decay into lighter mesons  $\mathcal{Q}\gamma_{\mathcal{N}}\mathcal{Q}$ ,  $\mathcal{L}\gamma_{\mathcal{N}}\mathcal{L}$  and  $\mathcal{Q}\mathcal{L}$ . Depending on the constituent masses  $m_{\mathcal{Q}}$  and  $m_{\mathcal{L}}$ , 2 or 3 of such mesons are stable because of the accidental fermion-number symmetries  $U(1)_Q$  and  $U(1)_{\mathcal{L}}$  present at the renormalizable level,<sup>2</sup> we will later discuss how the situation changes at the non-renormalizable level.

### 3.3 Axion effective Lagrangian

Under a  $U(1)_{\text{PQ}}$  rotation with angle  $\alpha$  the fields transform as

$$a \rightarrow a + \alpha\sqrt{\mathcal{N}/2}w, \quad \mathcal{Q} \rightarrow e^{+i\alpha/2}\mathcal{Q}, \quad \mathcal{L}^i \rightarrow e^{-i\alpha/2}\mathcal{L}^i.$$

The QCD and QED anomalies are

$$\mathcal{A}_{\text{QCD}} = \mathcal{N} \frac{g_3^2}{32\pi^2} G^{a\mu\nu} \tilde{G}_{\mu\nu}^a, \quad \mathcal{A}_{\text{QED}} = 3\mathcal{N} \frac{e^2}{16\pi^2} (Y_Q^2 - Y_{\mathcal{L}}^2) F^{\mu\nu} \tilde{F}_{\mu\nu}. \quad (3.7)$$

---

<sup>2</sup>The new sector also respects a  $\mathcal{C}$  symmetry [17] defined as  $\mathcal{S} \rightarrow \mathcal{S}^*$ ,  $\mathcal{D}_\mu \rightarrow \mathcal{D}_\mu^*$ ,  $\mathcal{F} \rightarrow i\gamma^2\mathcal{F}^\dagger$ , with  $\mathcal{F}$  denoting the various fermions. On the  $\text{Sp}(\mathcal{N})$  bosonic multiplets,  $\mathcal{C}$  acts as follows

$$s \rightarrow s, \quad a \rightarrow -a, \quad \tilde{s} \rightarrow -\gamma_{\mathcal{N}}\tilde{s}\gamma_{\mathcal{N}}, \quad \mathcal{A} \rightarrow -\gamma_{\mathcal{N}}\mathcal{A}\gamma_{\mathcal{N}}, \quad \mathcal{W} \rightarrow \gamma_{\mathcal{N}}\mathcal{W}\gamma_{\mathcal{N}}.$$

The colored fermions  $\mathcal{Q}$  relate this symmetry to the SM via QCD, so that  $\mathcal{C}$  (combined with parity) extends the usual charge-parity conjugation CP, under which the axion is odd, as it should.

In view of the above anomalies the effective axion Lagrangian is

$$\begin{aligned}\mathcal{L}_{\text{anom}}^{\text{eff}} &= \frac{a}{\sqrt{\mathcal{N}/2w}} \mathcal{N} \frac{g_3^2}{32\pi^2} G^{a\mu\nu} \tilde{G}_{\mu\nu}^a + \frac{a}{\sqrt{\mathcal{N}/2w}} 3\mathcal{N}(Y_Q^2 - Y_L^2) \frac{e^2}{16\pi^2} F^{\mu\nu} \tilde{F}_{\mu\nu} \\ &\equiv \frac{a}{f_a} \frac{g_3^2}{32\pi^2} G^{a\mu\nu} \tilde{G}_{\mu\nu}^a + \frac{g_{a\gamma}^0}{4} a F^{\mu\nu} \tilde{F}_{\mu\nu},\end{aligned}\tag{3.8}$$

where in the last step we identified the axion decay constant  $f_a = w/\sqrt{2\mathcal{N}}$  and coupling to photons  $g_{a\gamma}^0 = 3e^2(Y_Q^2 - Y_L^2)/4\pi^2 f_a$ . After rotating away the  $aG\tilde{G}$  term via an axion-dependent light quark field redefinition, the axion-photon coupling gets dressed via the axion-pion mixing as  $g_{a\gamma} = \alpha_{\text{em}} C_{a\gamma}/(2\pi f_a)$  in terms of the dimension-less coupling [27–29]

$$C_{a\gamma} = 6(Y_Q^2 - Y_L^2) - 1.92(4).\tag{3.9}$$

**Axion domain walls.** The QCD anomaly breaks  $U(1)_{\text{PQ}} \rightarrow \mathbb{Z}_{\mathcal{N}}$ , since the  $2\pi f_a$ -periodic axion potential has  $\mathcal{N}$  degenerate minima when the axion field is varied in its angular domain  $a \in [0, 2\pi) \sqrt{\mathcal{N}/2w} = [0, 2\pi) \mathcal{N} f_a$ . However, the  $\mathbb{Z}_{\mathcal{N}}$  action can be embedded in the  $SU(\mathcal{N})$  center, thus making the axion minima gauge equivalent. This avoids the formation of axion domain walls at the QCD phase transition, and solves the axion domain wall problem along the lines of [16, 30].

### 3.4 Higher dimensional operators

So far we considered the renormalizable theory. As anticipated, the relevance of the present model consists in the fact that the PQ symmetry arises accidentally at the renormalizable level and can remain good enough even in the presence of possible non-renormalizable operators. In this section we study how effective operators can break accidental symmetries, hence contributing to the axion potential and to the decay of heavy relics.

**PQ-breaking operators.** We defined the PQ symmetry such that the PQ charge of any field is proportional to its  $\mathcal{N}$ -ality (number of lower indices minus number of higher indices). This means that operators containing one  $\epsilon_{\mathcal{N}}$  tensor of  $SU(\mathcal{N})$  break the PQ symmetry, while it is preserved by all other operators, such as the renormalizable Yukawa couplings of eq. (3.2b), or the dimension-7 operator  $(q_R \mathcal{Q}_L) \mathcal{S}^* (q'_R \mathcal{Q}_L)$ . Note, also, that thanks to the  $\mathcal{N}$ -ality selection rule, dimension-7 operators are guaranteed to preserve the PQ symmetry even in the presence of additional “quarks” and “leptons” in arbitrary  $SU(3)_c \times U(1)_Y$  representations.

We then search for the lowest-dimensional operator containing one  $\epsilon_{\mathcal{N}}$  tensor. This is built by contracting with scalars  $\mathcal{S}$ , as replacing one  $\mathcal{S}_{IJ}$  with two fermions  $\mathcal{Q}_I$  or  $\bar{\mathcal{L}}_I$  increases the dimension of the operator. The lowest dimensional operator that explicitly breaks the accidental PQ symmetry is the Pfaffian, with dimension  $\mathcal{N}/2$

$$\text{Pf } \mathcal{S} = \sqrt{\det \mathcal{S}} = \epsilon_{\mathcal{N}}^{I_1 I_2 \dots I_{\mathcal{N}-1} I_{\mathcal{N}}} \mathcal{S}_{I_1 I_2} \dots \mathcal{S}_{I_{\mathcal{N}-1} I_{\mathcal{N}}}.\tag{3.10}$$

Assuming that new physics generates such operator with coefficient suppressed by some scale  $\Lambda_{\text{UV}}$ , its contribution to the axion potential originates from

$$\frac{e^{i\varphi}}{\Lambda_{\text{UV}}^{\mathcal{N}/2-4}} \text{Pf } \mathcal{S} + \text{h.c.},\tag{3.11}$$



where  $\varphi$  is a generic CP-violating phase. Inserting  $\text{Pf } \mathcal{S} = w^{\mathcal{N}/2} e^{ia/2f_a} + \dots$  the axion potential obtained from QCD plus eq. (3.11) is

$$V_a = -m_\pi^2 f_\pi^2 \cos\left(\frac{a}{f_a} + \bar{\theta}\right) + \frac{2w^{\mathcal{N}/2}}{\Lambda_{\text{UV}}^{\mathcal{N}/2-4}} \cos\left(\frac{a}{2f_a} + \varphi\right), \quad (3.12)$$

where  $\bar{\theta}$  is the QCD topological term in a basis in which the SM quark masses are real. The experimental bound  $\langle a/f_a \rangle + \bar{\theta} < 10^{-10}$  is satisfied for

$$f_a \lesssim \frac{\Lambda_{\text{UV}}}{\sqrt{\mathcal{N}/2}} \left(\frac{m_\pi f_\pi}{\Lambda_{\text{UV}}^2}\right)^{4/\mathcal{N}} \times 10^{-20/\mathcal{N}}. \quad (3.13)$$

Note that this bound holds even if the new physics respects CP,  $\varphi = 0$ , as the operator would not relax the axion to the field value that cancels CP violation at low energy and hence it would not cancel the  $\bar{\theta}$  term. If  $\Lambda_{\text{UV}} \sim M_{\text{Pl}}$ , the phenomenological bound  $f_a \gtrsim 10^{11}$  GeV for PQ symmetry broken after inflation requires  $\mathcal{N} \gtrsim 24$ . If, instead, the PQ symmetry is broken before inflation  $f_a$  can be as low as  $10^9$  GeV and then  $\mathcal{N} \gtrsim 20$  suffices. In our numerical plots we will assume for definiteness a Planckian cut-off. If instead  $\Lambda_{\text{UV}} \approx 2 \times 10^{16}$  GeV (as motivated e.g. by supersymmetric unification) one needs  $\mathcal{N} \gtrsim 24$  for  $f_a \gtrsim 10^9$  GeV.

The quality of the PQ symmetry is strengthened by the following argument. The operator in eq. (3.11) can have a coefficient  $\Lambda_{\text{UV}} \ll M_{\text{Pl}}$  if it is mediated by particles with renormalizable couplings below the Planck scale. One then needs a Yukawa or a scalar quartic containing the  $\epsilon_{\mathcal{N}}$  tensor, which implies particles in a  $\text{SU}(\mathcal{N})$  representation with  $n \sim \mathcal{N}/2$  or  $n \sim \mathcal{N}/3$  indices. The resulting large contribution to  $\beta(\mathfrak{g}) \sim \mathcal{N}^n$  implies that such particles cannot be much below the Planck scale.

**Q-decay operators.** Furthermore, gauge invariance allows dimension 6 operators such as

$$(q_R \mathcal{Q}_L^I)(e_R \mathcal{L}_I), \quad (q_R \mathcal{Q}_R^I)(q'_R \mathcal{L}_I), \quad (3.14)$$

(where  $q_R = (u_R, d_R)$  and  $e_R$  are left-handed Weyl spinors,  $\text{SU}(2)_L$ -singlet SM quarks and leptons) that conserve the PQ symmetry and break the other accidental global  $\text{U}(1)$ 's as

$$\text{U}(1)_{\mathcal{Q}} \otimes \text{U}(1)_{\mathcal{L}} \rightarrow \text{U}(1)_{\mathcal{Q}-\mathcal{L}} \quad (3.15)$$

such that only the lightest state containing  $\mathcal{Q}$  and/or  $\mathcal{L}$  is stable. Assuming that  $\mathcal{Q}$  is heavier than  $\mathcal{L}$ , heavier  $\text{Sp}$  bound states containing  $\mathcal{Q}$  decay with rate [31]

$$\Gamma_{\mathcal{Q}} \approx \frac{m_{\mathcal{Q}}^5}{4(4\pi)^3 \Lambda_{\text{UV}}^4} \left[ \frac{1-x^2}{2} + x \ln x \right] \approx \frac{1}{13 \text{ sec}} \left( \frac{m_{\mathcal{Q}}}{2 \times 10^{11} \text{ GeV}} \right)^5 \left( \frac{M_{\text{Pl}}}{\Lambda_{\text{UV}}} \right)^4, \quad (3.16)$$

for  $x \equiv m_{\mathcal{L}}/m_{\mathcal{Q}} \simeq 0.5$ . We can reasonably approximate the Big Bang Nucleosynthesis (BBN) bound on  $\mathcal{Q}$  decays [32] by simply demanding that  $\tau_{\mathcal{Q}} = 1/\Gamma_{\mathcal{Q}} < 0.1$  sec such that  $\mathcal{Q}$  decays before BBN. This gives the bound

$$f_a \gtrsim \frac{1}{y_{\mathcal{Q}}} \sqrt{\frac{10}{\mathcal{N}}} \left( \frac{\Lambda_{\text{UV}}}{M_{\text{Pl}}} \right)^{4/5} \times \begin{cases} 1.2 \times 10^{11} \text{ GeV} & \text{for } x = 1/2 \\ 0.7 \times 10^{11} \text{ GeV} & \text{for } x \ll 1 \end{cases}. \quad (3.17)$$

Furthermore we neglect the possibility that  $\mathcal{Q}$  decays while dominating the energy density of the universe and thereby providing extra reheating and dilution.

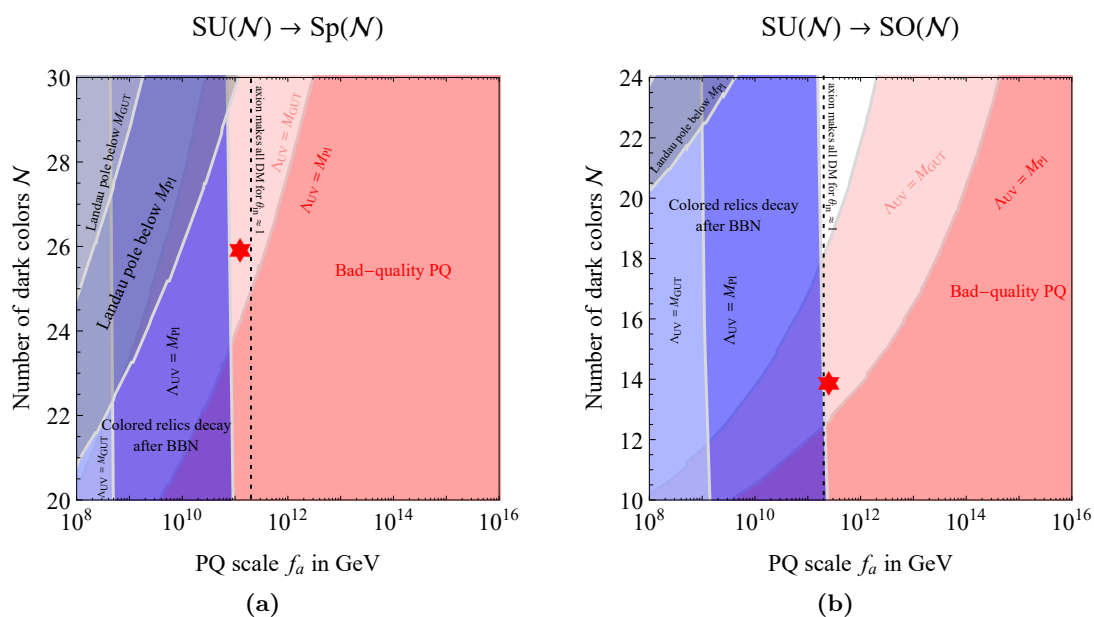

**Figure 1.** Values of  $(f_a, \mathcal{N})$  such that: i) the model gives rise to a high PQ-quality axion (the region shaded in red is excluded); ii) does not have sub-Planckian Landau poles for  $g_3$  (gray is excluded); iii) colored relics decay before BBN (blue is excluded if PQ is broken after inflation). We assumed  $y_Q = 1 = 2y_{\mathcal{L}}$  and non-renormalizable operators suppressed by  $\Lambda_{UV} \approx M_{\text{Pl}}$  (darker regions) or  $M_{\text{GUT}} \approx 2 \cdot 10^{16}$  GeV (lighter regions).  $\mathcal{N}$  should be understood as an integer parameter (even integer for the left-hand plot). *Left:* model with a scalar in the anti-symmetric. *Right:* model with a scalar in the anti-symmetric. The stars indicate the models considered in figure 3, 5, that satisfy all the bounds. They lie around the vertical dashed line, where axions with initial  $\theta_i \sim 1$  make all DM.

**$\mathcal{L}\mathcal{L}$ -decay operators.** The Sp mesons  $\mathcal{L}\gamma_{\mathcal{N}}\mathcal{L}$  with mass

$$M_{\mathcal{L}\mathcal{L}} \sim \max(\Lambda_{\text{Sp}}, 2y_{\mathcal{L}}w), \quad (3.18)$$

are possibly stable but are charged if  $Y_{\mathcal{L}} \neq 0$ . We avoid heavy charged relics assuming

$$Y_{\mathcal{L}} = 0 \quad \text{and} \quad Y_Q = \left\{ -\frac{1}{3}, \frac{2}{3}, -\frac{4}{3} \right\}. \quad (3.19)$$

For  $Y_{\mathcal{L}} = 0$  the Sp mesons are kept stable only by the accidental flavour symmetry that arises at renormalizable level and that gets broken if dimension-6 operators such as  $\mathcal{L}^i \mathcal{S} \mathcal{S}^\dagger \mathcal{S} \mathcal{L}^j$  have a different flavour structure. One then expects that  $\mathcal{L}\gamma_{\mathcal{N}}\mathcal{L}$  mesons decay fast, leaving no relics despite that  $\mathcal{L}$  is stable. We will however also mention the alternative possibility that  $\mathcal{L}\gamma_{\mathcal{N}}\mathcal{L}$  is an acceptable DM candidate with  $\tau_{\mathcal{L}\mathcal{L}} \gtrsim 10^{26}$  sec, given that flavour couplings might be small and not approximated by a single scale  $\Lambda_{UV}$ .

The bounds related to Landau poles and higher-dimensional operators (from BBN and PQ quality) are plotted in figure 1, which shows that they can all be simultaneously satisfied for  $\mathcal{N} \gtrsim 24$  and physically acceptable values of the axion decay constant  $f_a$ .

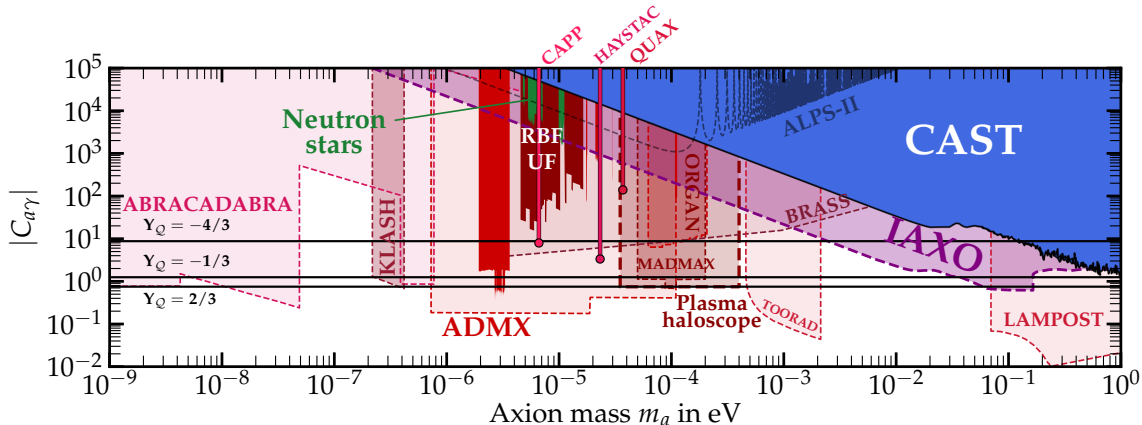

**Figure 2.** Predictions for the axion-photon coupling in eq. (3.9) and sensitivity of present and future axion experiments. Axion limits from [35].

**Axion-photon coupling predictions.** Requiring that the colored exotic states  $Q$  decay fast enough to avoid problems with cosmology allows to fix their hypercharges and in turn to predict the axion-photon coupling, following a similar strategy as in the case of KSVZ axions [33, 34]. In particular, in figure 2 we show the predictions for the dimension-less axion-photon coupling in eq. (3.9) according to the values of the hypercharges in eq. (3.19). Current limits (full lines) and projected ones (dashed lines) from axion experiments are displayed as well. It should be noted that most of those experiments (apart for CAST, IAXO and ALPS-II) assume that the axion comprises the 100% of DM. Consequently their sensitivity is diluted as  $(\Omega_a/\Omega_{\text{DM}})^{1/2}$ , if the axion is only a fraction of the whole DM. Hence, we next study the cosmology and the composition of the DM abundance.

### 3.5 Cosmology and Dark Matter

The model contains two DM candidates: the axion condensate and possibly the  $\mathcal{L}\gamma_N\mathcal{L}$  meson if  $Y_{\mathcal{L}} = 0$ . The reheating temperature after inflation is  $T_{\text{RH}} \sim \sqrt{M_{\text{Pl}}H_{\text{infl}}}$  if reheating happens instantaneously, or  $T_{\text{RH}} \sim \sqrt{M_{\text{Pl}}\Gamma_{\text{infl}}}$  otherwise. Qualitatively different cosmological histories arise depending on whether  $T_{\text{RH}}$  is high enough so that the PQ symmetry is restored after inflation.

#### 3.5.1 PQ broken before inflation, $T_{\text{RH}} \lesssim f_a$

If the PQ symmetry is broken during or before inflation and is not restored afterwards, the Hubble rate during inflation must be smaller than

$$H_{\text{infl}} \lesssim 10^8 \text{ GeV} \frac{\theta_i}{\pi} \frac{\Omega_{\text{DM}}}{\Omega_a} \frac{f_a}{10^{12} \text{ GeV}} \quad (3.20)$$

in order to avoid excessive axion iso-curvature fluctuations during inflation (see e.g. section 3.5 of [36]). This implies an upper bound on  $T_{\text{RH}}$ , that anyhow must be smaller than  $f_a$  under the present assumptions.

All the heavy stable relics including topological defects (strings from PQ breaking) get diluted during the inflationary expansion. The abundance of the DM candidates is estimated as follows:

- The axion DM abundance produced through the misalignment mechanism can be analytically approximated as [36]

$$\frac{\Omega_a h^2}{0.12} \approx \theta_{\text{in}}^2 \left( \frac{f_a}{2.0 \times 10^{11} \text{ GeV}} \right)^{7/6}, \quad (3.21)$$

where the initial axion phase  $\theta_{\text{in}}$  is expected to be of order one, but can accidentally be smaller.

- The  $\mathcal{L}\gamma\mathcal{N}\mathcal{L}$  meson  $\mathcal{M}_{\mathcal{L}}$  with mass  $M_{\mathcal{L}\mathcal{L}}$  given in eq. (3.18) might be stable and light enough that it is produced thermally.

- If  $T_{\text{RH}} \gtrsim \Lambda_{\text{Sp}}$  and possibly larger than  $m_{\mathcal{L}}$ , its constituents can be produced from  $\mathcal{A}\mathcal{A} \rightarrow \mathcal{L}\bar{\mathcal{L}}$  with rate  $\gamma \sim \mathbf{g}^4 T^4 e^{-2m_{\mathcal{L}}/T}$ . The resulting number abundance is

$$Y_{\mathcal{L}\mathcal{L}} \approx \max_T \frac{\gamma}{Hs} \sim \frac{\mathbf{g}^4 M_{\text{Pl}}}{\min(m_{\mathcal{L}}, T_{\text{RH}})} e^{-2m_{\mathcal{L}}/T_{\text{RH}}} \quad (3.22)$$

and gets later diluted by glue-ball decays.

- If  $T_{\text{RH}} \lesssim \Lambda_{\text{Sp}}$  it can be produced from  $aX \rightarrow \mathcal{M}_{\mathcal{L}}\bar{\mathcal{M}}_{\mathcal{L}}$  with space-time density rate  $\gamma \sim \Lambda_{\text{Sp}}^4 T^4 e^{-2M_{\mathcal{L}\mathcal{L}}/T} / f_a^4$ . The resulting number abundance is

$$Y_{\mathcal{L}\mathcal{L}} \approx \left. \frac{\gamma}{Hs} \right|_{T=T_{\text{RH}}} \sim e^{-2M_{\mathcal{L}\mathcal{L}}/T_{\text{RH}}} \frac{M_{\text{Pl}} \Lambda_{\text{Sp}}^4}{T_{\text{RH}} f_a^4}. \quad (3.23)$$

In figure 3a we show the parameter space of the model for some representative benchmark values. We select a high  $\mathcal{N} = 26$  such that DM can be composed solely by axions: in view of eq. (3.21) this happens along the vertical line in figure 3. More likely  $\mathcal{L}\mathcal{L}$  are unstable and the value of  $y_{\mathcal{L}}$  is irrelevant. We assumed a small  $y_{\mathcal{L}} = 10^{-3}$  such that, if  $\mathcal{L}\mathcal{L}$  is stable, a second DM branch appears in figure 3a in which DM is composed by mesons via thermal production. The transition between eq. (3.22) and eq. (3.23) gives rise to the discontinuity at  $T_{\text{RH}} \sim \Lambda_{\text{Sp}}$  in figure 3a.

### 3.5.2 PQ broken after inflation, $T_{\text{RH}} \gtrsim f_a$

We here consider the alternative situation where the reheating temperature is high enough that the PQ symmetry is restored after inflation and all the new states predicted by the model thermalise.

Demanding that axions do not exceed the cosmological DM density gives the bound  $f_a < 2.0 \times 10^{11} \text{ GeV}$  for the average initial misalignment angle  $\theta_{\text{in}} = 2.2$ . The latter numerical result (more precise than eq. (3.21)) is obtained by tracking the temperature dependence of the topological susceptibility via lattice QCD simulations [37]. If the PQ symmetry is broken after inflation, topological defects (strings and domain walls) add up to

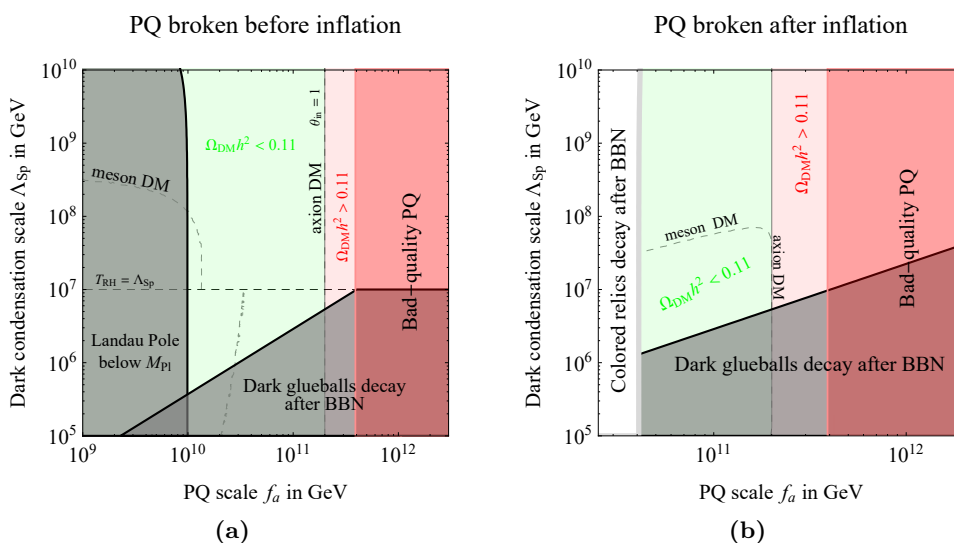
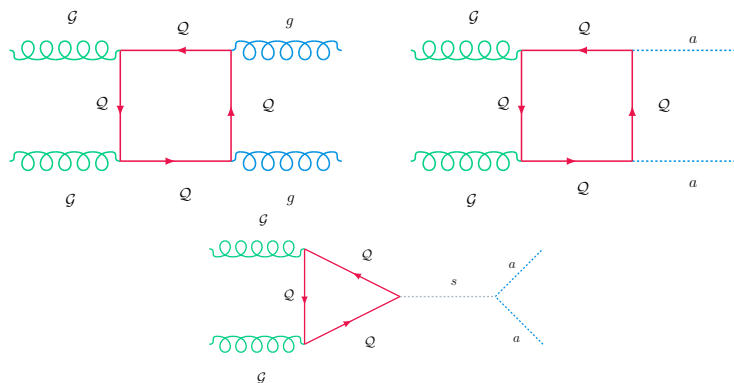

**Figure 3.** Parameter space of the SU(26) model assuming  $Y_{\mathcal{L}} = 0$ ,  $Y_{\mathcal{Q}} = -1/3$ , and  $y_{\mathcal{Q}} = 1$ . We chose a large  $\mathcal{N}$  such that the cosmological DM abundance is reproduced along the red/green boundary (the dashed curve shows how this boundary would change if, in addition to the axion, a cosmologically stable  $\mathcal{L}\mathcal{L}$  meson with  $y_{\mathcal{L}} = 10^{-3}$  contributes to DM; otherwise the same plots apply for any  $y_{\mathcal{L}} \ll y_{\mathcal{Q}}$ ). The right red region is disfavoured by the PQ quality arguments in eq. (3.13). *Left:* assuming that the PQ symmetry is broken before inflation with  $T_{\text{RH}} = 10^7 \text{ GeV} \ll f_a$ . The left gray region is excluded by sub-Planckian Landau poles. *Right:* assuming that  $T_{\text{RH}} \gtrsim f_a$ , i.e. PQ-breaking after inflation. The left white region is excluded because colored relics decay after BBN ( $\tau_{\mathcal{Q}} > 0.1 \text{ sec}$ ).

the total axion relic density. The contribution of would-be disastrous axion domain walls to the energy density is avoided thanks to the mechanism outlined at the end of section 3.3, while that of axion strings is relevant, but difficult to be estimated (see e.g. [38]). We neglect it here for simplicity, also because a complete consensus on their importance has not been achieved yet in the literature. However, recent developments indicate that they would strengthen the upper bound on  $f_a$  by more than one order of magnitude [39].

On the other hand, the possibly stable DM candidate  $\mathcal{L}\gamma_{\mathcal{N}}\mathcal{L}$  risks being over-abundant. Its thermal relic abundance,  $Y_{\mathcal{L}\mathcal{L}} \sim 1/T_{\text{dec}}M_{\text{Pl}}\sigma_{\text{ann}}$  with  $\sigma_{\text{ann}} \sim 1/\Lambda_{\text{Sp}}^2$  and  $T_{\text{dec}} \sim \Lambda_{\text{Sp}}$  (section 2.3 of [40] contains an extended discussion), is over-abundant if its mass  $M_{\mathcal{L}\mathcal{L}}$  is above than 100 TeV, the critical value above which even strongly-coupled freeze-out leaves too much DM. A  $\mathcal{L}\gamma_{\mathcal{N}}\mathcal{L}$  lighter than 100 TeV needs a very small  $y_{\mathcal{L}}$  and  $\Lambda_{\text{Sp}}$ .

Furthermore, the colored relics and the glue-balls of  $\text{Sp}(\mathcal{N})$  must decay before BBN, but their decay can be slow enough so that they substantially reheat the universe. Dark glue-balls decays dilute all relics containing  $\mathcal{Q}$  and  $\mathcal{L}$  heavy fermions (while the axion density is still a cosmological constant and hence is not diluted), allowing us to get a multi-component  $\mathcal{L}\gamma_{\mathcal{N}}\mathcal{L}$  plus axion abundance that matches the DM relic density. We anyhow demand that colored relics decay before BBN, which implies the bound found in eq. (3.17).



**Figure 4.** Some Feynman diagrams for dark glue-ball decay into gluons and axions. Analogous diagrams with heavy leptons  $\mathcal{L}$  or vectors  $\mathcal{W}$  in the loops are not plotted.

Glue-balls with mass  $\sim \Lambda_{\text{Sp}}$  that decay at  $T = T_{\text{decay}} \sim (\Gamma_{\text{DG}}^2 M_{\text{Pl}}^2 / \Lambda_{\text{Sp}})^{1/3}$  reheat the universe up to  $T_{\text{RH}'} \sim T_{\text{decay}} (\Lambda_{\text{Sp}} / T_{\text{decay}})^{1/3}$ . The dilution factor is estimated as [41]

$$D = \left[ 1 + \frac{g_{\text{DG}}}{g_{\text{SM}}} \left( \frac{\Lambda_{\text{Sp}}^2}{\Gamma_{\text{DG}} M_{\text{Pl}}} \right)^{\frac{2}{3}} \right]^{-1}, \quad (3.24)$$

where  $g_{\text{SM}} \approx 100$  is the number of SM degrees of freedom, and  $g_{\text{DG}} = \mathcal{N}(\mathcal{N} + 1)$  is the number of Sp dark gluons [42]. A large  $D$  can need a baryogenesis mechanism below  $T_{\text{RH}'}$ ; we do not address such model-dependent issues.

Dark glue-balls with mass  $M_{\text{DG}} \approx 7\Lambda_{\text{Sp}}$  can decay into axions and SM particles through the Feynman diagrams in figure 4. The rates are estimated as follows:

- Glue-balls decay into gluons  $g$  through a loop of  $Q$  (left-handed diagram in figure 4) that gives the dimension 8 effective operator  $\mathcal{A}_{\mu\nu}^2 g_{\alpha\beta}^2$  (see eq. (41) of [42])

$$\Gamma_{\text{DG} \rightarrow gg} \sim \frac{\alpha_{\text{DC}}^2 \alpha_3^2 M_{\text{DG}}^9}{m_Q^8}. \quad (3.25)$$

- Glue-balls decay into axions through a loop of  $Q$  or  $\mathcal{L}$  (middle diagram in figure 4) that gives the dimension 8 operator  $\mathcal{A}_{\mu\nu}^2 (\partial_\alpha a)^2$

$$\Gamma_{\text{DG} \rightarrow aa} \sim \frac{\alpha_{\text{DC}}^2 M_{\text{DG}}^9}{m_{Q,\mathcal{L}}^8} \left( \frac{m_{Q,\mathcal{L}}}{4\pi f_a} \right)^2. \quad (3.26)$$

A similar diagram gives decays into  $ag$ .

- Glue-balls decay into axions as described by the right-handed diagram in figure 4: through the dimension 5 operator  $(18 - 7\mathcal{N})\alpha_{\text{DC}}\mathcal{A}_{\mu\nu}^2 s / 16\pi w$  times the dimension 5  $s(\partial_\alpha a)^2$  operator

$$\Gamma_{\text{DG} \rightarrow aa} \approx \frac{(18 - 7\mathcal{N})^2 \alpha_{\text{DC}}^2 M_{\text{DG}}^9}{512\pi^3 M_s^4 f_a^4}. \quad (3.27)$$

- Glue-balls decay into  $HH^\dagger = \{hh, hZ, ZZ, W^+W^-\}$  proceed through the coupling  $\lambda_{HS}$  that connects the dark and the SM sectors (that however can be small, in order to avoid an unnaturally large contribution to the Higgs mass). Taking into account that  $h$  mixes with  $s$  we obtain, for  $M_{\text{DG}} \gg M_{h,W,Z}$

$$\Gamma_{\text{DG} \rightarrow HH^\dagger} \approx \frac{(18 - 7\mathcal{N})^2 \alpha_{\text{DC}}^2 \lambda_{HS}^2 M_{\text{DG}}^5}{2048\pi^3 M_s^4}. \tag{3.28}$$

The most important channels are (3.26) and (3.27) for  $y_{\mathcal{L}} \ll 1$ , while (3.27) dominates if  $y_{\mathcal{L}} \sim 1$ .

The parameter space is plotted in figure 3b: we see that regions exist where all constraints are satisfied, the axion quality is good, and the DM cosmological abundance is reproduced either through axions or through dark mesons (if stable), or both.

#### 4 Symmetric scalar that breaks $\text{SU}(\mathcal{N}) \rightarrow \text{SO}(\mathcal{N})$

We next consider a different but similar model: the scalar is now in the symmetric representation and spontaneously breaks the  $\text{SU}(\mathcal{N})$  gauge group to  $\text{SO}(\mathcal{N})$ . We avoid repeating the many aspects of the model which remain similar to those in section 3 and highlight the key differences.

If  $\mathcal{N} > 4$  the most generic renormalizable Lagrangian has the same form as in eqs. (3.1) and (3.2). The Yukawa matrix  $y_{\mathcal{L}}$  is now symmetric and can be rotated to a basis where it is diagonal with real positive entries. Unlike the anti-symmetric scalar, where the gauge invariant Pfaffian operator is defined only for even  $\mathcal{N}$ , the symmetric scalar model can also be constructed using odd values of  $\mathcal{N}$ . We again require that couplings do not hit Landau poles below the Planck scale; SM couplings run as in the previous model, giving the same constraints.

**Accidental symmetries.** The situation is similar to the model of section 3, but with two differences.

First, in both models the  $\text{SU}(\mathcal{N})$  theory is accidentally invariant under a reflection, which we dub U-parity [17], of any of the  $\mathcal{N}$  equivalent directions in group space. U-parity is obtained by flipping the sign of any color, for example the 1st one. This flips the signs of those generators with an  $1I$  entry, preserving the  $\text{SU}(\mathcal{N})$  Lie algebra, such that U parity acts on components of vectors in the adjoint and of other multiplets as

$$\mathcal{G}_I^J \xrightarrow{\mathcal{P}_U} (-1)^{\delta_{1I} + \delta_{1J}} \mathcal{G}_I^J, \quad \mathcal{Q}_I \xrightarrow{\mathcal{P}_U} (-1)^{\delta_{1I}} \mathcal{Q}_I, \quad \mathcal{L}_I \xrightarrow{\mathcal{P}_U} (-1)^{\delta_{1I}} \mathcal{L}_I, \quad \mathcal{S}_{IJ} \xrightarrow{\mathcal{P}_U} (-1)^{\delta_{1I} + \delta_{1J}} \mathcal{S}_{IJ} \tag{4.1}$$

having written the  $\text{SU}(\mathcal{N})$  vectors as  $\mathcal{G}_J^I = \mathcal{G}^A (T^A)_J^I$ . We ignored U-parity when discussing the  $\text{SU}(\mathcal{N}) \rightarrow \text{Sp}(\mathcal{N})$  breaking in the previous section, because U-parity was broken by  $\langle \mathcal{S} \rangle$ . In the present model, instead, U-parity is preserved when  $\text{SU}(\mathcal{N})$  is spontaneously broken by  $\langle \mathcal{S} \rangle = w \mathbf{1}_{\mathcal{N}}$  to  $\text{SO}(\mathcal{N})$ . As a result,  $\text{SO}(\mathcal{N})$  confinement produces dark baryons odd under U-parity: those built by contracting constituents with one  $\epsilon_{\mathcal{N}}$ . The lightest of such baryons is a stable DM candidate.

The  $U(1)_{\text{PQ}}$  symmetry again acts as shown in table 1. If  $Y_{\mathcal{L}} \neq 0$  all accidental global symmetries are the same as in the previous model, eq. (3.3). The second difference arises if  $Y_{\mathcal{L}} = 0$ : leptons now acquire a Majorana mass, so  $U(1)_{\mathcal{L}}$  lepton number gets replaced by a  $\mathbb{Z}_2$  that acts as lepton parity  $\mathcal{L}^i \rightarrow -\mathcal{L}^i$ . The accidental global symmetries become  $U(1)_{\mathcal{Q}} \otimes \mathbb{Z}_2 \otimes U(1)_{\text{PQ}}$ .

#### 4.1 Symmetry breaking and perturbative spectrum

In a range of potential parameters, the scalar  $\mathcal{S}$  acquires vacuum expectation value  $\langle \mathcal{S} \rangle = w\mathbf{1}_{\mathcal{N}}$ . This breaks  $SU(\mathcal{N}) \otimes U(1)_{\text{PQ}}$  to  $SO(\mathcal{N})$  leaving one axion and giving mass to all fermions. Following [17] the scalar field is conveniently parametrised as

$$\mathcal{S} = \left[ \left( w + \frac{s}{\sqrt{2\mathcal{N}}} \right) \text{diag}(1, \dots, 1) + (\tilde{s}^b + i\tilde{a}^b) T_{\text{real}}^b \right] e^{\frac{ia}{\sqrt{2\mathcal{N}}w}} \quad (4.2)$$

where  $T_{\text{real}}^b$  are the real (symmetric) generators of  $SU(\mathcal{N})$  in the fundamental representation, while  $s, \tilde{s}, \tilde{a}, a$  are canonically normalized fields. The mass spectrum at the perturbative level is:

- $\mathcal{N}(\mathcal{N} - 1)/2$  massless vectors  $\mathcal{A}^a$  in the adjoint of  $SO(\mathcal{N})$ .
- $\mathcal{N}(\mathcal{N} + 1)/2 - 1$  vectors  $\mathcal{W}^b$  in the traceless symmetric of  $SO(\mathcal{N})$ , that acquire a squared mass  $M_{\mathcal{W}}^2 = 4\mathfrak{g}^2 w^2$  eating the Goldstone bosons  $\tilde{a}^b$ .
- The massless scalar  $a$ , singlet under  $SO(\mathcal{N})$ . In view of its QCD anomalies it can be called axion and its decay constant will be  $f_a = w/\sqrt{\mathcal{N}/2}$ .
- the scalar  $s$ , singlet under  $SO(\mathcal{N})$ . If symmetry breaking arises through the Coleman-Weinberg mechanism it is light with squared mass  $M_s^2 = 6(\mathcal{N}\lambda_{\mathcal{S}} + \lambda'_{\mathcal{S}})w^2$ .
- $\mathcal{N}(\mathcal{N} + 1)/2 - 1$  scalars  $\tilde{s}^b$  with squared mass  $M_{\tilde{s}}^2 = 2(\mathcal{N}\lambda_{\mathcal{S}} + 3\lambda'_{\mathcal{S}})w^2$ .
- One colored Dirac quark  $\Psi_{\mathcal{Q}} = (\mathcal{Q}_L, \bar{\mathcal{Q}}_R)^T$  with mass  $M_{\mathcal{Q}} = y_{\mathcal{Q}}w$  in the fundamental representation of  $SO(\mathcal{N})$  charged under the accidental global  $U(1)_{\mathcal{Q}}$ .
- Three Dirac leptons  $\Psi_{\mathcal{L}}^i = (\mathcal{L}_L^i, \bar{\mathcal{L}}_R^i)^T$  with masses  $M_{\mathcal{L}^i} = y_{\mathcal{L}}^i w$  in the fundamental of  $SO(\mathcal{N})$  charged under the accidental global  $U(1)_{\mathcal{L}^i}$  if  $Y_{\mathcal{L}} \neq 0$ . If  $Y_{\mathcal{L}} = 0$  one instead gets six Majorana leptons  $\Psi_{\mathcal{L}}^i = (\mathcal{L}^i, \bar{\mathcal{L}}^i)^T$  with masses  $M_{\mathcal{L}^i} = y_{\mathcal{L}}^i w$  in the fundamental of  $SO(\mathcal{N})$  which transform as  $\Psi_{\mathcal{L}}^i \rightarrow -\Psi_{\mathcal{L}}^i$  under the accidental  $\mathbb{Z}_2$  symmetry.

The quarks  $\mathcal{Q}$  are perturbatively stable thanks to the accidental global  $U(1)_{\mathcal{Q}}$  while the leptons  $\mathcal{L}^i$  are stable thanks to the global  $U(1)_{\mathcal{L}^i}$  (if  $Y_{\mathcal{L}} \neq 0$ ) or the discrete  $\mathbb{Z}_2$  symmetries (if  $Y_{\mathcal{L}} = 0$ ).

#### 4.2 Confinement and bound states

The  $SO(\mathcal{N})$  gauge dynamics confines at the energy scale

$$\Lambda_{\text{SO}} \approx f_a \exp \left[ -\frac{6\pi}{11(\mathcal{N} - 2)\alpha_{\text{DC}}(f_a)} \right]. \quad (4.3)$$



The theory contains a CP parity that extends the QCD CP parity analogously to what discussed in footnote 2.  $SO(\mathcal{N})$  confinement leads to bound states, and we are interested in the possibly stable states. These are the SO baryons formed by contracting constituents with an anti-symmetric  $\epsilon_{\mathcal{N}}$  tensor of  $SO(\mathcal{N})$ , taking into account that group theory allows SO gluons to be constituents.

- If  $\mathcal{N}$  is even the lightest baryon is the 0-ball  $\epsilon_{\mathcal{N}}\mathcal{A}^{\mathcal{N}/2}$  made of SO gluons only, stable thanks to U-parity (see e.g. [17]). On the other hand, the lighter baryons containing fermions

$$\epsilon_{\mathcal{N}}\mathcal{A}^{(\mathcal{N}-2)/2}\mathcal{Q}\mathcal{Q}, \quad \epsilon_{\mathcal{N}}\mathcal{A}^{(\mathcal{N}-2)/2}\mathcal{L}\mathcal{L}, \quad \epsilon_{\mathcal{N}}\mathcal{A}^{(\mathcal{N}-2)/2}\mathcal{Q}\mathcal{L} \quad (4.4)$$

can decay respecting U-parity into the 0-ball plus the corresponding lighter mesons  $\mathcal{Q}\mathcal{Q}$ ,  $\mathcal{L}\mathcal{L}$ ,  $\mathcal{Q}\mathcal{L}$ . Such mesons are stable in the limit of exact  $U(1)_{\mathcal{Q},\mathcal{L}}$  symmetries.

- If  $\mathcal{N}$  is odd the lightest baryons contain one fermion (and thereby dubbed 1-ball)

$$\epsilon_{\mathcal{N}}\mathcal{A}^{(\mathcal{N}-1)/2}\mathcal{Q}, \quad \epsilon_{\mathcal{N}}\mathcal{A}^{(\mathcal{N}-1)/2}\mathcal{L} \quad (4.5)$$

are stable if the fermion  $\mathcal{Q}$  and/or  $\mathcal{L}$  is stable.

### 4.3 Higher dimensional operators

Unlike in the model with an anti-symmetric discussed as in section 3.4, in the present model with a symmetric the lowest dimensional operator that breaks the PQ symmetry is  $\det \mathcal{S}$  at dimension  $\mathcal{N}$ . PQ quality now demands a weaker bound on  $f_a$ ,

$$f_a \lesssim \frac{\Lambda_{\text{UV}}}{\sqrt{\mathcal{N}}} \left( \frac{m_{\pi} f_{\pi}}{\Lambda_{\text{UV}}^2} \right)^{2/\mathcal{N}} \times 10^{-10/\mathcal{N}}, \quad (4.6)$$

having identified  $f_a = w/\sqrt{\mathcal{N}/2}$ , since the construction of the axion effective Lagrangian follows exactly section 3.3. Consequently, PQ quality is now assured if  $\mathcal{N} \gtrsim 12$  for both  $\Lambda_{\text{UV}} \simeq M_{\text{GUT}}$  and  $f_a \gtrsim 10^9$  GeV or  $\Lambda_{\text{UV}} \simeq M_{\text{Pl}}$  and  $f_a \gtrsim 10^{11}$  GeV, the latter for PQ symmetry broken after inflation, otherwise  $\mathcal{N} \gtrsim 10$  is enough.

The dimension 6 operators in eq. (3.14) that break fermion numbers are allowed for  $Y_{\mathcal{Q}} \pm Y_{\mathcal{L}} = \left\{ -\frac{1}{3}, \frac{2}{3}, -\frac{4}{3} \right\}$ . Assuming  $M_{\mathcal{Q}} > M_{\mathcal{L}}$ , the colored states  $\mathcal{Q}$  decay with rate given in eq. (3.16). Demanding again  $\tau_{\mathcal{Q}} < 0.1$  sec in order to avoid problems with BBN we derive a bound on  $f_a$  a factor of 2 stronger than in eq. (3.17). Assuming that  $\mathcal{Q}$  decays, the stable relics are:

	if $Y_{\mathcal{L}} \neq 0$	if $Y_{\mathcal{L}} = 0$	
if $\mathcal{N}$ is odd	$\epsilon_{\mathcal{N}}\mathcal{A}^{(\mathcal{N}-1)/2}\mathcal{L}$ and $\mathcal{L}\mathcal{L}$	$\epsilon_{\mathcal{N}}\mathcal{A}^{(\mathcal{N}-1)/2}\mathcal{L}$	(4.7)
if $\mathcal{N}$ is even	$\epsilon_{\mathcal{N}}\mathcal{A}^{\mathcal{N}/2}$ and $\mathcal{L}\mathcal{L}$	$\epsilon_{\mathcal{N}}\mathcal{A}^{\mathcal{N}/2}$	

$Y_{\mathcal{L}} = 0$  is needed to have no charged relics.

The interplay between Landau pole, BBN and PQ-quality constraints is displayed in figure 1b, while for the given values of  $Y_{\mathcal{Q}} = \left\{ -\frac{1}{3}, \frac{2}{3}, -\frac{4}{3} \right\}$  and  $Y_{\mathcal{L}} = 0$  the predictions for the axion-photon coupling are the same as in figure 2.

#### 4.4 $SU(\mathcal{N})/SO(\mathcal{N})$ monopoles?

A qualitatively new feature of the  $SU(\mathcal{N}) \rightarrow SO(\mathcal{N})$  model is the presence of an unusual type of magnetic monopoles. Indeed, while the model of section 3 had a trivial second homotopy group  $\pi_2(SU(\mathcal{N})/Sp(\mathcal{N})) = 0$ , in the present model  $\pi_2(SU(\mathcal{N})/SO(\mathcal{N})) = \mathbb{Z}_2$  is non-trivial and allows for topologically stable  $\mathbb{Z}_2$  monopoles [43] with mass  $M_{\text{mon}} \approx M_W/\alpha_{\text{DC}}$ .  $\mathbb{Z}_2$  monopoles differ from the well known monopoles carrying a  $U(1)$  magnetic charge by the fact that their charge is discrete, modulo 2, so that two  $\mathbb{Z}_2$  monopole annihilate. Their semi-classical limit was constructed in [43–45]. It was later realised that such monopoles fill multiplets under an emerging magnetic dual group: in the present theory they likely fill a representation of a magnetic Goddard-Nuyts-Olive (GNO) [46] dual group [47, 48]. Monopoles and their vectors are massless in theories where super-symmetries allow us to reliably compute gauge dynamics beyond the semi-classical approximation [48, 49], but not in the present theory.

Furthermore, in our theory  $SO(\mathcal{N})$  is unbroken and (most likely) confines at a lower scale  $\Lambda_{\text{SO}}$ . Thereby  $SO(\mathcal{N})$  magnetic fields cannot reach infinity, casting doubts on the topological argument for monopole stability. Indeed, it is believed that  $SO(\mathcal{N})$  confinement corresponds, in the dual theory, to full Higgsing of the magnetic GNO dual group [48], so that monopoles can mix with electric states and decay. We will then study cosmology assuming no stable monopoles.

However, as non-perturbative gauge dynamics is not firmly known, we also consider the opposite, less likely, possibility of stable monopoles. Then monopoles contribute to the DM density, with the abundance estimated in the rest of this section. Monopoles form at the  $SU(\mathcal{N}) \rightarrow SO(\mathcal{N})$  cosmological phase transition. As long as  $M_W, f_a \gg \Lambda_{\text{SO}}$  the short-distance dynamics of monopole formation is not affected by  $SO(\mathcal{N})$  confinement and the estimates for cosmological monopole production via the Kibble mechanism [50] apply. If the  $SU(\mathcal{N}) \rightarrow SO(\mathcal{N})$  phase transition is of second order, the Kibble-Zurek estimate [51, 52] is

$$\Omega_{\text{mon}} h^2 = 1.5 \times 10^9 \left( \frac{M_{\text{mon}}}{1 \text{ TeV}} \right) \left( \frac{30 T_c}{M_{\text{Pl}}} \right)^{\frac{3\nu}{1+\nu}}, \quad (4.8)$$

where  $T_c \approx M_W$  is the critical temperature of the phase transition and  $\nu$  is the related critical exponent ( $\nu = 1/2$  at classical level).

If instead the transition is of first order, the Kibble estimate is enhanced by a logarithmic factor due to the process of bubble nucleation [53]:

$$\Omega_{\text{mon}} h^2 = 1.7 \times 10^{11} \left( \frac{M_{\text{mon}}}{1 \text{ TeV}} \right) \left[ \frac{T_c}{\sqrt{45/(4\pi^3 g_{\text{SM}})} M_{\text{Pl}}} \ln \left( \left( \frac{45}{4\pi^3 g_{\text{SM}}} \right)^2 \frac{M_{\text{Pl}}^4}{T_c^4} \right) \right]^3, \quad (4.9)$$

where  $g_{\text{SM}} \approx 100$  is the number of SM degrees of freedom. Finally, the monopole abundance gets diluted by monopole annihilations and possibly by inflation (if PQ is broken before inflation) or by dark glue-ball decays (if PQ is broken after inflation).

#### 4.5 Cosmology and Dark Matter

DM is composed by axions, by the 0-ball  $\epsilon \mathcal{A}^{\mathcal{N}/2}$  (for even  $\mathcal{N}$ ) or the 1-ball  $\epsilon \mathcal{A}^{(\mathcal{N}-1)/2} \mathcal{L}$  (for odd  $\mathcal{N}$  and  $Y_{\mathcal{L}} = 0$ ), and possibly by monopoles (if stable). As in the  $Sp$  model, we consider the two possible cases.

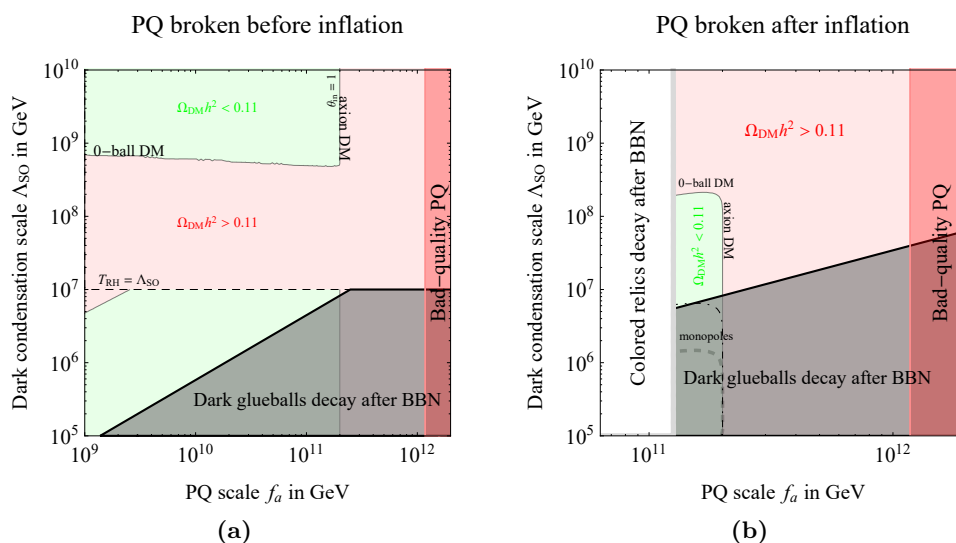

**Figure 5.** Allowed regions in the  $(f_a, \Lambda_{\text{SO}})$  plane for the SU(14) model with a scalar in the symmetric, assuming  $y_{\mathcal{Q}} = 1$ ,  $y_{\mathcal{L}} = 0.1$ ,  $Y_{\mathcal{L}} = 0$ ,  $Y_{\mathcal{Q}} = -1/3$ . DM is composed by axions and 0-balls. The relic DM abundance is reproduced along the boundaries between the red/green regions. White (gray) regions are excluded because  $\mathcal{Q}$  (dark glue-balls) decay after BBN. The region at large  $f_a$  is disfavoured by poor PQ quality, eq. (4.6). *Left:* we assume PQ-breaking before inflation with  $T_{\text{RH}} = 10^7 \text{ GeV} \ll f_a$ . The axion DM abundance is computed for  $\theta_{\text{in}} = 1$ . *Right:* PQ-breaking after inflation. We assumed that monopoles decay; otherwise they contribute as well to the DM density and the curve along which the DM abundance is reproduced becomes the dashed curve (Kibble-Zurek estimate) or the dot-dashed curve (Kibble-Zurek plus an estimate of monopole annihilations).

#### 4.5.1 PQ broken before inflation, $T_{\text{RH}} \lesssim f_a$

Inflation dilutes all relics, so cosmology is similar to what is discussed in section 3.5.1 for the Sp model. Sp mesons containing  $2\mathcal{L}$  get replaced by SO bound states containing  $0\mathcal{L}$  or  $1\mathcal{L}$ . Their relic abundance is again estimated assuming that such states have a non-perturbative annihilation cross section of order  $1/\Lambda_{\text{SO}}^2$ . Figure 5a considers the case of even  $\mathcal{N} = 14$ , showing that there are regions where all constraints are satisfied and the cosmological abundance reproduced, as combinations of axions and heavy relics.<sup>3</sup> For odd  $\mathcal{N}$  the relics containing  $1\mathcal{L}$  can be heavier than  $\Lambda_{\text{SO}}$ , and thereby have a smaller abundance produced by thermal scatterings after inflation. Nevertheless, one can again find regions where all constraints are satisfied.

#### 4.5.2 PQ broken after inflation, $T_{\text{RH}} \gtrsim f_a$

Relics are now not diluted by inflation. Still, abundances at the desired level are obtained taking into account that they annihilate with cross section  $\sigma_{\text{ann}} \sim 100/\Lambda_{\text{SO}}^2$  and that glueballs can decay slowly, reheating the lighter particles and diluting the heavier relics. We

<sup>3</sup>If  $\Lambda_{\text{SO}}$  is smaller than  $T_{\text{RH}}$  a thermal-equilibrium population of dark gluons is present, that later dilutes the 0-ball number density, when it dominates the energy density of the Universe in the form of long-lived dark glueballs. Hence, 0-balls are under-abundant for  $\Lambda_{\text{SO}} \lesssim T_{\text{RH}}$ .

anyhow demand that  $\mathcal{Q}$  relics decay before BBN, finding the extra bound  $f_a \gtrsim 10^{11}$  GeV in figure 5b. Axions and glue-balls behave as in section 3.5.2, except that now  $g_{\text{DG}} = \mathcal{N}(\mathcal{N} - 1)$  and the scalon-gluon effective Lagrangian becomes  $-(7\mathcal{N} + 10)\alpha_{\text{DC}}(\mathcal{A}_{\mu\nu})^2 s/8\pi w$ . Figure 5b shows that regions exist where all constraints are satisfied, the axion quality is good and the cosmological DM abundance reproduced. We here considered even  $\mathcal{N} = 14$ ; similar results are found for odd  $\mathcal{N}$ .

So far we assumed that monopoles decay. As this is not firmly established, we also consider the possibility that stable monopoles contribute to the DM abundance. Assuming the Kibble-Zurek estimate (dashed curve) we find that monopoles tend to be too much abundant in the allowed regions. This is partially avoided by adding estimated monopole annihilations (dot-dashed curve). As order unity factor become relevant and  $\mathcal{N}$  is somehow large, a more reliable estimate of the monopole abundance should take into account that monopoles fill some representation of the GNO dual group.

## 5 Conclusions

We proposed two simple models that provide a high-quality accidental PQ symmetry. The models are based on  $SU(\mathcal{N})$  gauge dynamics spontaneously broken to either  $Sp(\mathcal{N})$  or  $SO(\mathcal{N})$  by a scalar  $\mathcal{S}$  in the anti-symmetric or symmetric and heavy quarks and leptons in the fundamental, as summarized in table 1. The PQ symmetry acts as a phase rotation of  $\mathcal{S}$  and is only broken by operators involving the  $SU(\mathcal{N})$  anti-symmetric invariant tensor with  $\mathcal{N}$  indices. If  $\mathcal{S}$  is symmetric the lowest-dimensional operator that breaks the PQ symmetry is  $\det \mathcal{S}$  with dimension  $\mathcal{N}$ . If  $\mathcal{S}$  is anti-symmetric the lowest-dimensional operator that breaks the PQ symmetry is  $\text{Pf } \mathcal{S} = \sqrt{\det \mathcal{S}}$  with dimension  $\mathcal{N}/2$ . A high-quality PQ symmetry is thereby obtained for large enough  $\mathcal{N}$ . Putting together constraints of theoretical type (PQ quality and no sub-Planckian Landau poles, see figure 1) and of phenomenological type (colored relics decaying before BBN, cosmological DM density), the models are viable if  $\mathcal{N} \gtrsim 12$  (for the symmetric) or  $\mathcal{N} \gtrsim 24$  (for the anti-symmetric).

The models contain extra accidental symmetries that can lead to heavy relics. Generic non-renormalizable operators break some accidental symmetries. With an appropriate choice of heavy fermion hypercharges and masses, heavy quarks decay before BBN into heavy leptons, that form bound states together with dark vectors when the unbroken color group ( $SO$  or  $Sp$ ) confines at some scale  $\Lambda$ . Depending on the model, such bound states either decay or leave cosmologically stable relics that provide extra DM candidates beyond the axion.

If the PQ symmetry is broken before inflation, extra relics get diluted away and are only marginally produced at reheating, so that DM candidates can have the desired abundance.

If the PQ symmetry is broken after inflation, thermal relics of super-heavy particles are typically over-abundant. This is not necessarily a problem, as the models under consideration contain dark glue-balls that decay mildly slowly and can thereby partially dilute the heavier relics (while the axion density, still in the form of vacuum energy, does not get diluted). As a result, we find regions in the  $(f_a, \Lambda)$  plane where all constraints are satisfied, as shown in figure 3, 5. Furthermore, in the  $SU(\mathcal{N}) \rightarrow SO(\mathcal{N})$  model,  $\mathbb{Z}_2$  monopoles

arise at the cosmological phase transition. We argued that  $\text{SO}(\mathcal{N})$  confinement ruins their topological stability, but we also considered the opposite possibility of stable monopoles, showing that they could provide extra DM through the Kibble-Zurek mechanism.

All in all, such models predict strongly coupled dynamics at  $\Lambda \ll f_a$  and are thereby more testable than other proposed solutions to the PQ quality problem (based e.g. on discrete or abelian gauge symmetries), where the new dynamics remains confined to very high energies. While  $\Lambda$  might be larger than scales explorable at colliders, the new physics has implications for cosmology, with possible non-trivial cosmological interplays among different sources of DM.

Finally, we point out that the mechanism outlined in the present paper to address the axion quality problem could be also employed to protect the shift-symmetry of a generic Goldstone boson, as e.g. in the case of ultra-light fuzzy DM [55] or cosmological approaches to the hierarchy problem (see e.g. [56]). These scenarios typically require a shift-symmetry with a quality significantly higher than the axion case, that would be difficult to achieve otherwise, especially if the quantum-gravity breaking is not exponentially suppressed in the presence of radial modes, as claimed in [54]. The mechanism outlined here provides a natural framework to achieve such a high-quality shift-symmetry, given its robustness (the symmetry is  $\mathcal{N}$ -ality) and protecting power (the breaking can be suppressed to an arbitrarily high value by increasing  $\mathcal{N}$ ). We leave a detailed study to future work.

## Acknowledgments

We thank Claudio Bonati, Ken Konishi, Michele Redi and Alfredo Urbano for useful discussions. This work was supported by the ERC grant NEO-NAT. The work of LDL is supported by the Marie Skłodowska-Curie Individual Fellowship grant AXIONRUSH (GA 840791) and the Deutsche Forschungsgemeinschaft under Germany's Excellence Strategy — EXC 2121 Quantum Universe — 390833306. The work of JWW is supported by the China Scholarship Council with Grant No. 201904910660. This research is supported in part by the MIUR under contract 2017FMJFMW (PRIN2017).

**Open Access.** This article is distributed under the terms of the Creative Commons Attribution License ([CC-BY 4.0](https://creativecommons.org/licenses/by/4.0/)), which permits any use, distribution and reproduction in any medium, provided the original author(s) and source are credited.

## References

- [1] R.D. Peccei and H.R. Quinn, *CP Conservation in the Presence of Instantons*, *Phys. Rev. Lett.* **38** (1977) 1440 [[INSPIRE](#)].
- [2] R.D. Peccei and H.R. Quinn, *Constraints Imposed by CP Conservation in the Presence of Instantons*, *Phys. Rev. D* **16** (1977) 1791 [[INSPIRE](#)].
- [3] H.M. Georgi, L.J. Hall and M.B. Wise, *Grand Unified Models With an Automatic Peccei-Quinn Symmetry*, *Nucl. Phys. B* **192** (1981) 409 [[INSPIRE](#)].
- [4] M. Dine and N. Seiberg, *String Theory and the Strong CP Problem*, *Nucl. Phys. B* **273** (1986) 109 [[INSPIRE](#)].

- [5] S.M. Barr and D. Seckel, *Planck scale corrections to axion models*, *Phys. Rev. D* **46** (1992) 539 [INSPIRE].
- [6] M. Kamionkowski and J. March-Russell, *Planck scale physics and the Peccei-Quinn mechanism*, *Phys. Lett. B* **282** (1992) 137 [hep-th/9202003] [INSPIRE].
- [7] R. Holman, S.D.H. Hsu, T.W. Kephart, E.W. Kolb, R. Watkins and L.M. Widrow, *Solutions to the strong CP problem in a world with gravity*, *Phys. Lett. B* **282** (1992) 132 [hep-ph/9203206] [INSPIRE].
- [8] S. Ghigna, M. Lusignoli and M. Roncadelli, *Instability of the invisible axion*, *Phys. Lett. B* **283** (1992) 278 [INSPIRE].
- [9] L.F. Abbott and M.B. Wise, *Wormholes and Global Symmetries*, *Nucl. Phys. B* **325** (1989) 687 [INSPIRE].
- [10] S.R. Coleman and K.-M. Lee, *Wormholes made without massless matter fields*, *Nucl. Phys. B* **329** (1990) 387 [INSPIRE].
- [11] R. Kallosh, A.D. Linde, D.A. Linde and L. Susskind, *Gravity and global symmetries*, *Phys. Rev. D* **52** (1995) 912 [hep-th/9502069] [INSPIRE].
- [12] R. Alonso and A. Urbano, *Wormholes and masses for Goldstone bosons*, *JHEP* **02** (2019) 136 [arXiv:1706.07415] [INSPIRE].
- [13] A. Hebecker, T. Mikhail and P. Soler, *Euclidean wormholes, baby universes, and their impact on particle physics and cosmology*, *Front. Astron. Space Sci.* **5** (2018) 35 [arXiv:1807.00824] [INSPIRE].
- [14] A. Salvio and A. Strumia, *Agravity*, *JHEP* **06** (2014) 080 [arXiv:1403.4226] [INSPIRE].
- [15] C. Gross, A. Strumia, D. Teresi and M. Zirilli, *Is negative kinetic energy meta-stable?*, [arXiv:2007.05541] [INSPIRE].
- [16] L. Di Luzio, E. Nardi and L. Ubaldi, *Accidental Peccei-Quinn symmetry protected to arbitrary order*, *Phys. Rev. Lett.* **119** (2017) 011801 [arXiv:1704.01122] [INSPIRE].
- [17] D. Buttazzo et al., *Scalar gauge dynamics and Dark Matter*, *JHEP* **01** (2020) 130 [arXiv:1911.04502] [INSPIRE].
- [18] L. Randall, *Composite axion models and Planck scale physics*, *Phys. Lett. B* **284** (1992) 77 [INSPIRE].
- [19] B.A. Dobrescu, *The Strong CP problem versus Planck scale physics*, *Phys. Rev. D* **55** (1997) 5826 [hep-ph/9609221] [INSPIRE].
- [20] M. Redi and R. Sato, *Composite Accidental Axions*, *JHEP* **05** (2016) 104 [arXiv:1602.05427] [INSPIRE].
- [21] B. Lillard and T.M.P. Tait, *A High Quality Composite Axion*, *JHEP* **11** (2018) 199 [arXiv:1811.03089] [INSPIRE].
- [22] H.-S. Lee and W. Yin, *Peccei-Quinn symmetry from a hidden gauge group structure*, *Phys. Rev. D* **99** (2019) 015041 [arXiv:1811.04039] [INSPIRE].
- [23] M.B. Gavela, M. Ibe, P. Quilez and T.T. Yanagida, *Automatic Peccei-Quinn symmetry*, *Eur. Phys. J. C* **79** (2019) 542 [arXiv:1812.08174] [INSPIRE].
- [24] E. Nardi, *Naturally large Yukawa hierarchies*, *Phys. Rev. D* **84** (2011) 036008 [arXiv:1105.1770] [INSPIRE].

- [25] J.R. Espinosa, C.S. Fong and E. Nardi, *Yukawa hierarchies from spontaneous breaking of the  $SU(3)_L \times SU(3)_R$  flavour symmetry?*, *JHEP* **02** (2013) 137 [[arXiv:1211.6428](#)] [[INSPIRE](#)].
- [26] C.S. Fong and E. Nardi, *Quark masses, mixings, and CP-violation from spontaneous breaking of flavor  $SU(3)^3$* , *Phys. Rev. D* **89** (2014) 036008 [[arXiv:1307.4412](#)] [[INSPIRE](#)].
- [27] D.B. Kaplan, *Opening the Axion Window*, *Nucl. Phys. B* **260** (1985) 215 [[INSPIRE](#)].
- [28] M. Srednicki, *Axion Couplings to Matter. 1. CP Conserving Parts*, *Nucl. Phys. B* **260** (1985) 689 [[INSPIRE](#)].
- [29] G. Grilli di Cortona, E. Hardy, J. Pardo Vega and G. Villadoro, *The QCD axion, precisely*, *JHEP* **01** (2016) 034 [[arXiv:1511.02867](#)] [[INSPIRE](#)].
- [30] G. Lazarides and Q. Shafi, *Axion Models with No Domain Wall Problem*, *Phys. Lett. B* **115** (1982) 21 [[INSPIRE](#)].
- [31] H.M. Asatrian, A. Hovhannisyanyan and A. Yeghiazaryan, *The phase space analysis for three and four massive particles in final states*, *Phys. Rev. D* **86** (2012) 114023 [[arXiv:1210.7939](#)] [[INSPIRE](#)].
- [32] M. Kawasaki, K. Kohri and T. Moroi, *Big-Bang nucleosynthesis and hadronic decay of long-lived massive particles*, *Phys. Rev. D* **71** (2005) 083502 [[astro-ph/0408426](#)] [[INSPIRE](#)].
- [33] L. Di Luzio, F. Mescia and E. Nardi, *Redefining the Axion Window*, *Phys. Rev. Lett.* **118** (2017) 031801 [[arXiv:1610.07593](#)] [[INSPIRE](#)].
- [34] L. Di Luzio, F. Mescia and E. Nardi, *Window for preferred axion models*, *Phys. Rev. D* **96** (2017) 075003 [[arXiv:1705.05370](#)] [[INSPIRE](#)].
- [35] C. O'Hare, *cajohare/AxionLimits: AxionLimits*, *Zenodo* 7 July 2020.
- [36] L. Di Luzio, M. Giannotti, E. Nardi and L. Visinelli, *The landscape of QCD axion models*, *Phys. Rept.* **870** (2020) 1 [[arXiv:2003.01100](#)] [[INSPIRE](#)].
- [37] S. Borsányi et al., *Calculation of the axion mass based on high-temperature lattice quantum chromodynamics*, *Nature* **539** (2016) 69 [[arXiv:1606.07494](#)] [[INSPIRE](#)].
- [38] M. Gorghetto, E. Hardy and G. Villadoro, *Axions from Strings: the Attractive Solution*, *JHEP* **07** (2018) 151 [[arXiv:1806.04677](#)] [[INSPIRE](#)].
- [39] M. Gorghetto, E. Hardy and G. Villadoro, *More Axions from Strings*, [arXiv:2007.04990](#) [[INSPIRE](#)].
- [40] D. Buttazzo, L. Di Luzio, G. Landini, A. Strumia and D. Teresi, *Dark Matter from self-dual gauge/Higgs dynamics*, *JHEP* **10** (2019) 067 [[arXiv:1907.11228](#)] [[INSPIRE](#)].
- [41] G. Landini and J.-W. Wang, *Dark Matter in scalar  $Sp(\mathcal{N})$  gauge dynamics*, *JHEP* **06** (2020) 167 [[arXiv:2004.03299](#)] [[INSPIRE](#)].
- [42] A. Mitridate, M. Redi, J. Smirnov and A. Strumia, *Dark Matter as a weakly coupled Dark Baryon*, *JHEP* **10** (2017) 210 [[arXiv:1707.05380](#)] [[INSPIRE](#)].
- [43] E.J. Weinberg, D. London and J.L. Rosner, *Magnetic Monopoles With  $Z_n$  Charges*, *Nucl. Phys. B* **236** (1984) 90 [[INSPIRE](#)].
- [44] D. London, *Is the Doubly Charged Monopole Stable?*, *Phys. Rev. D* **33** (1986) 3075 [[INSPIRE](#)].
- [45] F.A. Bais and R. Laterveer, *Exact  $Z_N$  Monopole Solutions in Gauge Theories With Nonadjoint Higgs Representations*, *Nucl. Phys. B* **307** (1988) 487 [[INSPIRE](#)].
- [46] P. Goddard, J. Nuyts and D.I. Olive, *Gauge Theories and Magnetic Charge*, *Nucl. Phys. B* **125** (1977) 1 [[INSPIRE](#)].

- [47] R. Auzzi, S. Bolognesi, J. Evslin, K. Konishi and H. Murayama, *NonAbelian monopoles*, *Nucl. Phys. B* **701** (2004) 207 [[hep-th/0405070](#)] [[INSPIRE](#)].
- [48] K. Konishi, *The Magnetic Monopoles Seventy-Five Years Later*, in *Lecture Notes in Physics* **737**, Springer (2007), pp. 471–521 [[hep-th/0702102](#)] [[INSPIRE](#)].
- [49] N. Seiberg and E. Witten, *Monopoles, duality and chiral symmetry breaking in  $N = 2$  supersymmetric QCD*, *Nucl. Phys. B* **431** (1994) 484 [[hep-th/9408099](#)] [[INSPIRE](#)].
- [50] T.W.B. Kibble, *Topology of Cosmic Domains and Strings*, *J. Phys. A* **9** (1976) 1387 [[INSPIRE](#)].
- [51] W.H. Zurek, *Cosmological Experiments in Superfluid Helium?*, *Nature* **317** (1985) 505 [[INSPIRE](#)].
- [52] H. Murayama and J. Shu, *Topological Dark Matter*, *Phys. Lett. B* **686** (2010) 162 [[arXiv:0905.1720](#)] [[INSPIRE](#)].
- [53] A.H. Guth and E.J. Weinberg, *Could the Universe Have Recovered from a Slow First Order Phase Transition?*, *Nucl. Phys. B* **212** (1983) 321 [[INSPIRE](#)].
- [54] J. Alvey and M. Escudero, *The Axion Quality Problem: Global Symmetry Breaking and Wormholes*, [arXiv:2009.03917](#) [[INSPIRE](#)].
- [55] L. Hui, J.P. Ostriker, S. Tremaine and E. Witten, *Ultralight scalars as cosmological dark matter*, *Phys. Rev. D* **95** (2017) 043541 [[arXiv:1610.08297](#)] [[INSPIRE](#)].
- [56] A. Strumia and D. Teresi, *Relaxing the Higgs mass and its vacuum energy by living at the top of the potential*, *Phys. Rev. D* **101** (2020) 115002 [[arXiv:2002.02463](#)] [[INSPIRE](#)].