

# Clinical profile and long-term follow-up of a cohort of patients with desmoplakin cardiomyopathy



Riccardo Bariani, MD,\* Marco Cason, PhD,\* Iliaria Rigato, MD, PhD,\*  
Alberto Cipriani, MD,\* Rudy Celegghin, MSc, PhD,\* Monica De Gaspari, MD,\*  
Maria Bueno Marinas, MSc, PhD,\* Giulia Mattesi, MD,\* Valeria Pergola, MD,\*  
Stefania Rizzo, MD, PhD,\* Alessandro Zorzi, MD, PhD,\* Benedetta Giorgi, MD,†  
Alessandra Rampazzo, PhD,‡ Gaetano Thiene, MD,\* Sabino Iliceto, MD,\*  
Martina Perazzolo Marra, MD, PhD,\* Domenico Corrado, MD, PhD,\*  
Cristina Basso, MD, PhD,\* Kalliopi Pilichou, MSc, PhD,\*<sup>1</sup> Barbara Bauce, MD, PhD\*<sup>1</sup>

From the \*Department of Cardiac, Thoracic, Vascular Sciences and Public Health, University of Padua, Padua, Italy, †Radiology Division, Department of Medicine, University of Padua, Padua, Italy, and ‡Department of Biology, University of Padua, Padua, Italy.

**BACKGROUND** Desmoplakin (*DSP*) genetic variants have been reported in arrhythmogenic cardiomyopathy with particular regard to predominant left ventricular (LV) involvement.

**OBJECTIVE** The purpose of this study was to improve our understanding of clinical phenotype and outcome of *DSP* variant carriers.

**METHODS** The clinical picture and outcome of 73 patients (36% probands) harboring a pathogenic/likely pathogenic *DSP* variant were evaluated.

**RESULTS** The phenotype during follow-up (mean 11 years; range 1–39 years) changed in 25 patients (35%), arrhythmogenic LV cardiomyopathy (ALVC) forms being the most frequent ( $n = 26$  [36%]), followed by biventricular (BIV;  $n = 20$  [27%]) and arrhythmogenic right ventricular cardiomyopathy (ARVC;  $n = 16$  [22%]) forms. Major ventricular arrhythmias were detected in 21 patients (29%), and they were more common in ARVC ( $n = 6$ , 56%) and BIV forms ( $n = 8$ , 40%) than in ALVC forms ( $n = 4$ , 15%). In patients with ALVC, major ventricular arrhythmias occurred in the setting of a normal/mildly reduced systolic function. Heart failure (HF) occurred in

6 patients (8%); none affected with ALVC. Females showed more commonly LV involvement, while ARVC forms were more frequently detected in males (21 [61%] vs 15 [38%];  $P = .147$ ). Males showed a higher incidence of major ventricular arrhythmias (18 [52%] vs 9 [24%];  $P = .036$ ), HF (11 [31%] vs 1 [3%];  $P = .004$ ), and cardiac death (11 [31%] vs 0 [0%];  $P < .001$ ).

**CONCLUSION** The clinical phenotype in pathogenic/likely pathogenic *DSP* variant carriers is wide. Although most patients show LV involvement, 16 (22%) has right ventricular abnormalities in keeping with a “classical” arrhythmogenic cardiomyopathy form. In ALVC, HF and major ventricular arrhythmias seem less common than in right ventricular and BIV variants. Females show more frequently LV involvement and a better outcome.

**KEYWORDS** Desmoplakin; Arrhythmogenic cardiomyopathy; Dilated cardiomyopathy; Ventricular arrhythmias; Sudden cardiac death

(Heart Rhythm 2022;19:1315–1324) © 2022 Heart Rhythm Society. This is an open access article under the CC BY-NC-ND license (<http://creativecommons.org/licenses/by-nc-nd/4.0/>).

## Introduction

Rare variants in the desmoplakin (*DSP*) gene were for the first time linked to cardiomyopathy in patients with Carvajal syndrome, a cardiocutaneous syndrome characterized by

dilated cardiomyopathy (DCM), palmoplantar keratoderma, and woolly hair.<sup>1</sup> Few years later, an association between *DSP* variants and arrhythmogenic cardiomyopathy (ACM) was reported by our group.<sup>2,3</sup>

In 2008, Sen-Chowdhry et al<sup>4</sup> described a clinical entity named “arrhythmogenic left dominant cardiomyopathy” (ALVC) characterized by a predominant left ventricular (LV) involvement, with no or minor right ventricular (RV) abnormalities. The phenotype of ACM has then been recognized to be wider than previously thought, including right dominant (arrhythmogenic RV cardiomyopathy [ARVC]) and left dominant (ALVC) forms at the extremes of the spectrum.<sup>5</sup> In the following years, several studies demonstrated a correlation between ALVC and radical *DSP* variants.<sup>5,6</sup> More

Funding Sources: This work was supported by the Registry for Cardio-cerebro-vascular Pathology, Veneto Region, Venice, Italy; Ministry of Health grant and RFI/2013I/02356762; and RFI/2014I/00000394 University Research grants CPDA144300 and BIRD162733, Padua, Italy; PRIN Ministry of Education, University and Research 2015ZLNETW\_001, Rome, Italy; and the CARIPARO Foundation, Padua, Italy. Disclosures: The authors have no conflicts of interest to disclose. <sup>1</sup>These 2 coauthors shared the senior authorship. **Address reprint requests and correspondence:** Dr Barbara Bauce, Division of Cardiology, Department of Cardiac, Thoracic, Vascular Sciences and Public Health, University of Padua, Via Giustiniani, 2 35121 Padua, Italy. E-mail address: [barbara.bauce@unipd.it](mailto:barbara.bauce@unipd.it).

recently, Smith et al<sup>7</sup> collected a series of patients carrying *DSP* truncating variants proposing the term “desmoplakin cardiomyopathy” to describe a clinical phenotype characterized by a large amount of LV fibrosis, episodes of myocardial necrosis, and a significant degree of electrical.

In this article we present a retrospective study regarding clinical features of a large single-center cohort of consecutive patients carrying pathogenic/likely pathogenic (P/LP) *DSP* variants with long follow-up with the aim to achieve new insights into the clinical spectrum and outcome.

## Methods

From the entire cohort of probands and family members followed at the cardiomyopathy unit of the University of Padua, we selected those carrying a P/LP variant of the *DSP* gene. Patients with variants in other genes were excluded.

All patients provided written informed consent before inclusion in the study in accordance with the protocol approved by the regional ethics committee. All clinical investigations were conducted according to the principles expressed in the Declaration of Helsinki.

Patients underwent a complete clinical and evaluation assessment with personal and family history, 12-lead electrocardiogram (ECG), 24-hour Holter ECG, 2-dimensional echocardiogram, and cardiac magnetic resonance (CMR). When available, ventricular arrhythmia morphology (left bundle branch block [LBBB] and right bundle branch block [RBBB]) was reported.

Similar to other authors' publications, subjects were divided into different groups (ALVC, ARVC, and biventricular [BIV] forms)<sup>4,7</sup> according to RV and LV function with the aim to compare clinical and instrumental data. Details are reported in [Online Supplemental Methods](#).

Rare *DSP* (NM 004415.2) variants were described to be linked to ACM, suggesting the need to assess the diagnostic value of 2010 ACM Task Force criteria and of recently published Padua criteria.<sup>8,9</sup> The latter, although not yet validated in multicenter cohorts, is characterized by an increased sensitivity for the diagnosis of left dominant forms through the implementation of new parameters as morphofunctional and tissue characterization of the LV at CMR, ECG repolarization changes in inferolateral leads, and arrhythmia morphology in keeping with LV origin (RBBB morphology).

The presence of previous myocarditis, defined as hospital admission due to chest pain and myocardial damage markers detection in the absence of coronary arteries disease, was investigated.<sup>7,10</sup> Patients entered a follow-up program with a yearly evaluation with the same protocol.

The detailed description of the protocol followed for ECG, echocardiogram, CMR, genetic analysis, and statistical analysis has been provided in [Online Supplemental Methods](#).

## Results

We identified a total of 112 patients carrying a *DSP* variant, of whom 18 were excluded as carriers of benign variants and 21 carriers of variant of uncertain significance. A total of 73

subjects harboring a P/LP *DSP* variant (26 probands [36%]; median age at diagnosis 33 years; interquartile range 19–50 years) were eventually enrolled ([Online Supplemental Table 1](#)).

Curly hairs were present in 32 patients (44%): in detail, 4 (36%) without cardiac phenotype, 6 (38%) with ARVC, 9 (34%) with ALVC, and 13 (65%) with a BIV form. Furthermore, only 1 patient belonging to ALVC had palmoplantar keratoderma.

Taking into consideration the 26 probands, 7 (27%) had a family history of sudden cardiac death (SCD) and 13 (50%) of cardiomyopathy (ACM in 12 cases and DCM in 1 case). The reason for first evaluation was detection of ventricular arrhythmia (VA) ( $n = 14$  [54%]) or ECG abnormalities ( $n = 12$  [46%]). One proband died suddenly after a first cardiac evaluation, and genetic analysis was performed post-mortem.<sup>11</sup>

Among the 26 probands carrying a P/LP *DSP* variant, we were able to screen family members in 19 (73%) patients. Overall, 87 family members were analyzed with identification of a P/LP *DSP* variant in 47 (54%) subjects. Thus, a total of 73 patients were finally included in our cohort. Five family members (11%) already had a diagnosis of cardiac disease. The relative risk of developing ACM features in family members carrying a P/LP *DSP* variant is increased (relative risk 23.34;  $P < .0001$ ) as compared to the general population, but similar survival rates were seen after adjustment for age and cause of ACM in this cohort. As such, the presence of familial clustering does not necessarily affect the results.

## Genotype-phenotype correlation

At the first evaluation, 20 of 73 patients (27%; 11 males and 9 females; mean age  $36 \pm 17$  years; minimum 18 years; maximum 69 years) were classified as having ARVC, 26 (36%; 13 males and 13 females; mean age  $36 \pm 16$  years; minimum 12 years; maximum 66 years) had ALVC, and 7 (10%; 4 males and 3 females; mean age  $51 \pm 19$  years; minimum 18 years; maximum 74 years) had a BIV form. A total of 20 P/LP *DSP* variant carriers (27%; 7 males, 13 females; mean age  $29 \pm 21$  years; minimum 9 years; maximum 84 years), all family members, did not show any morphological or tissue abnormality.

At the last evaluation, 20 patients (27%; 8 males and 12 females; mean age  $36 \pm 15$  years; minimum 10 years; maximum 65 years) were classified in a different phenotypic group as compared with the first evaluation. ALVC was confirmed as the most common clinical phenotype (36%; 9 males and 17 females; mean age  $34 \pm 18$  years; minimum 10 years; maximum 66 years), followed by BIV form (27%; 9 males and 11 females; mean age  $42 \pm 16$  years; minimum 18 years; maximum 74 years) and ARVC (22%; 11 males and 5 females; mean age  $36 \pm 18$  years; minimum 18 years; maximum 69 years) ([Figure 1](#)). A total of 11 P/LP *DSP* variant carriers (15%; mean age  $26 \pm 24$  years) still showed unremarkable instrumental findings.

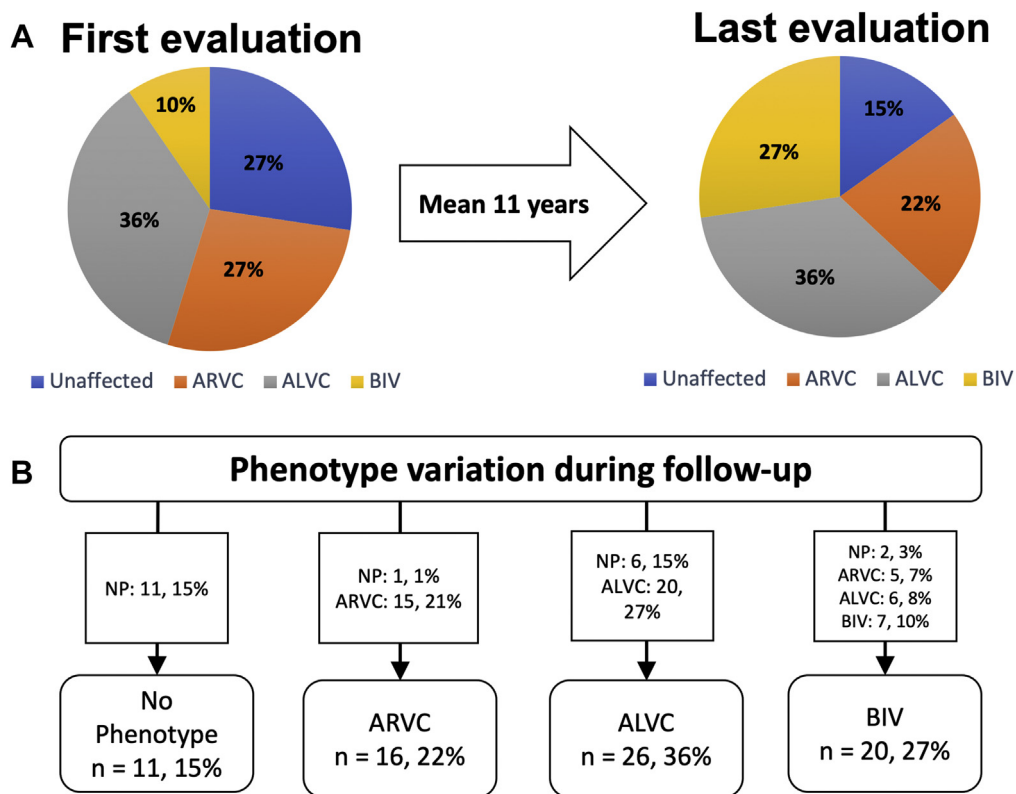

**Figure 1** Analysis of the phenotypic variation observed during the mean 11-year follow-up period. **A:** Clinical phenotypes at the first evaluation and at the end of follow-up. **B:** Transitions from initial to last phenotypic expression. ALVC = left dominant phenotype; ARVC = right dominant phenotype; BIV = biventricular phenotype; NP = no phenotype.

By using the 2010 ACM criteria, a definite diagnosis was achieved in 32 patients (42%; 19 males and 13 females), with a significant difference when comparing ALVC and ARVC or BIV form (23% vs 69% and 75%, respectively;  $P = .009$ ). When applying the Padua criteria, 49 patients (67%; 23 males and 26 females) reached a definite diagnosis. Furthermore, we performed a comparative analysis with the 2010 Task Force criteria that did not demonstrate an increase in sensitivity for predicting arrhythmic events, heart failure (HF), or sudden death ( $P = .537$ ).

Considering sex analysis, the ALVC (17 females [65%]), BIV (11 females [55%]), and unaffected (6 females [55%]) groups consisted mainly of female subjects as compared with the ARVC group (5 females [31%]) ( $P = .204$ ).

The clinical characteristics of patients at last follow-up are summarized in Table 1.

In 8 of 19 families (42%), an intrafamilial variability with the presence of patients with ALVC and BIV/ARVC was observed (Figures 2 and 3).

#### ECG features

ECG features are summarized in Table 2. All subjects were in sinus rhythm except 1 (1%) who presented with atrial fibrillation. The most common findings were low QRS voltages in the limb leads ( $n = 32$  [44%]), followed by T-wave inversion (TWI) in leads  $V_1$ – $V_3$  ( $n = 15$  [21%]) and in leads  $V_4$ – $V_6$

( $n = 16$  [22%]). A total of 13 patients (18%) showed low QRS voltages in the precordial leads as well. The epsilon wave was uncommon ( $n = 2$  [3%]).

Eight patients (11%) developed a first-degree atrioventricular block, which remained unchanged during follow-up. In 12 cases (16%), a fragmented QRS complex was observed. One patient (1%) showed LBBB, and 3 (4%) RBBB.

A comparison between the 3 phenotypic groups showed that TWI in leads  $V_1$ – $V_3$  were more common in the ARVC group ( $n = 7$  [44%]) than in the ALVC group ( $n = 2$  [8%]) ( $P = .024$ ). Similarly, low QRS voltages in the limb leads were found more frequently in those with ALVC ( $n = 13$  [50%]) and a BIV form ( $n = 12$  [60%]) than in those with ARVC ( $n = 6$  [38%]) ( $P = .037$ ). No other significant differences were found (Table 2).

#### VAs

A 24-hour ECG Holter monitor was available in all 73 subjects, and in 46 (63%), the presence of VA was documented. In detail, 18 patients (39%) showed rare premature ventricular contractions (PVCs), 20 (43%) frequent PVCs (>500 per 24 hours), and 8 (17) nonsustained ventricular tachycardia episodes.

Analysis of VA morphology was available for 45 subjects (71%) and showed LBBB morphology in 30 (87% ARVC

**Table 1** General data of patients with a pathogenic/likely pathogenic variant on the *DSP* gene at the end of follow-up

Variable	Phenotype					<i>P</i>
	Overall (N = 73 [100%])	Unaffected (n = 11 [15%])	ARVC (n = 16 [22%])	ALVC (n = 26 [36%])	BIV (n = 20 [27%])	
Age at diagnosis (y)	33 (19–50)	14 (10–44)	33 (30–51)	27 (18–45)	44 (30–51)	.028
Male sex	34 (47)	5 (46)	11 (68)	9 (35)	9 (45)	.204
Probands	26 (36)	0 (0)	7 (54)	8 (31)	11 (52)	.001
Myocarditis	11 (15)	0 (0)	3 (19)	5 (19)	3 (15)	.530
Family history of SCD	22 (30)	3 (27)	4 (25)	10 (39)	5 (25)	.754
Family history of DCM	5 (7)	0 (0)	0 (0)	3 (12)	2 (10)	.524
Family history of ACM	53 (73)	11 (100)	8 (50)	19 (73)	15 (75)	.034
Syncope	10 (16)	1 (9)	1 (6)	4 (15)	3 (15)	.568
Atrial fibrillation	2 (3)	0 (0)	2 (14)	0 (0)	0 (0)	.067
ICD	26 (36)	0 (0)	8 (50)	6 (23)	12 (60)	.001
Diagnosis						
Certain	32 (42)	0 (0)	11 (69)	6 (23)	15 (75)	<.001
Borderline	21 (29)	0 (0)	4 (25)	15 (58)	2 (10)	
Possible	9 (12)	0 (0)	1 (6)	5 (19)	3 (15)	
No diagnosis	11 (15)	11 (100)	0 (0)	0 (0)	0 (0)	

Continuous variables are expressed as median (25th–75th percentile). Categorical variables are expressed as absolute number (percentage).

ACM = arrhythmogenic cardiomyopathy; ALVC = arrhythmogenic left dominant cardiomyopathy; ARVC = arrhythmogenic right ventricular cardiomyopathy; BIV = biventricular; DCM = dilated cardiomyopathy; ICD = implantable cardioverter-defibrillator; SCD = sudden cardiac death.

and 80% BIV form;  $P = .676$ ) and RBBB in 15 cases (42% ALVC and 20% BIV form;  $P = .128$ ).

A total of 26 subjects (36%; 14 males and 12 females) received an implantable cardioverter-defibrillator, and a significant difference was observed between those with ARVC ( $n = 8$  [50%]) and those with ALVC ( $n = 19$  [73%]) or a BIV form ( $n = 15$  [75%]) ( $P = .001$ ).

### CMR findings

CMR was available in 56 patients (77%). Data on BIV dimension, function, wall motion alteration, and tissue characterization are reported in [Table 2](#).

Analysis of RV parameters showed that subjects with BIV and ARVC forms did not differ significantly. In LV analysis, end-diastolic volume values were higher ( $P = .003$ ) and ejection fraction (EF) was lower in BIV forms than in ARVC and ALVC forms ( $P = .003$ ). Regarding LV-late gadolinium enhancement (LGE), the most peculiar pattern of distribution was the subepicardial stria, frequently located in the basal segments of the inferolateral wall. In ALVC and BIV forms, the extent of LGE often exceeded 2 segments, in contrast to ARVC forms ( $P = .012$ ).

### Episodes of clinically suspected myocarditis

A total of 11 subjects (15%; 6 probands and 5 family members; 4 males and 7 females; mean age  $27 \pm 13$  years) experienced episodes of chest pain with myocardial enzyme release in the presence of normal coronary arteries. None of them showed major VAs (MVAs) during the acute event, while 2 had MVAs during follow-up (mean 6 years). None of these patients experienced HF either during the myocardial episode or during follow-up.

### Follow-up

The mean follow-up period was 11 years (range 1–39 years). No statistical difference was found between the 3 phenotypes regarding the number of PVCs both at the first ( $P = .113$ ) and at the last ( $P = .086$ ) evaluation.

At the first evaluation, 39 patients (53%) were on medical therapy, and the most common drugs were  $\beta$ -blockers (67%) and sotalol (23%). At last follow-up, 50 patients (68%) were on antiarrhythmic therapy (70%  $\beta$ -blockers, 23% sotalol, and 7% amiodarone).

A detailed description of major arrhythmic events, comprehensive of SCD, divided according to phenotype, is provided in [Online Supplemental Table 2](#).

Documented MVAs occurred in 21 subjects (29%; 14 males and 7 females;  $P = .039$ ; mean age at event  $45 \pm 15$  years), and significant differences were found among the 3 groups (ARVC:  $n = 9$  [56%]; ALVC:  $n = 4$  [15%]; BIV:  $n = 8$  [40%]; ARVC vs ALVC,  $P = .014$ ). In patients with sustained ventricular tachycardia, the mean cycle length observed was  $251 \pm 33$  bpm. All subjects with an ALVC form and MVAs showed normal or mildly reduced EF (mean  $53\% \pm 10\%$ ; minimum 40%; maximum 68%).

Eight patients (7 males and 1 female; median age 48 years; interquartile range 29–65 years;  $P = .018$ ) died during follow-up because of a cardiac cause (ARVC:  $n = 5$  [31%]; ALVC:  $n = 1$  [4%]; BIV:  $n = 2$  [10%];  $P = .009$ ): refractory HF in 2 cases and SCD with an autopsy finding in keeping with ACM in the remaining 6. Two additional patients died of noncardiac causes. Episodes of HF occurred in 6 patients (8%). In detail, 2 had an ARVC form (13%; 1 female and 1 male) and 4 a BIV form (20%; 3 males and 1 female) while none belonged

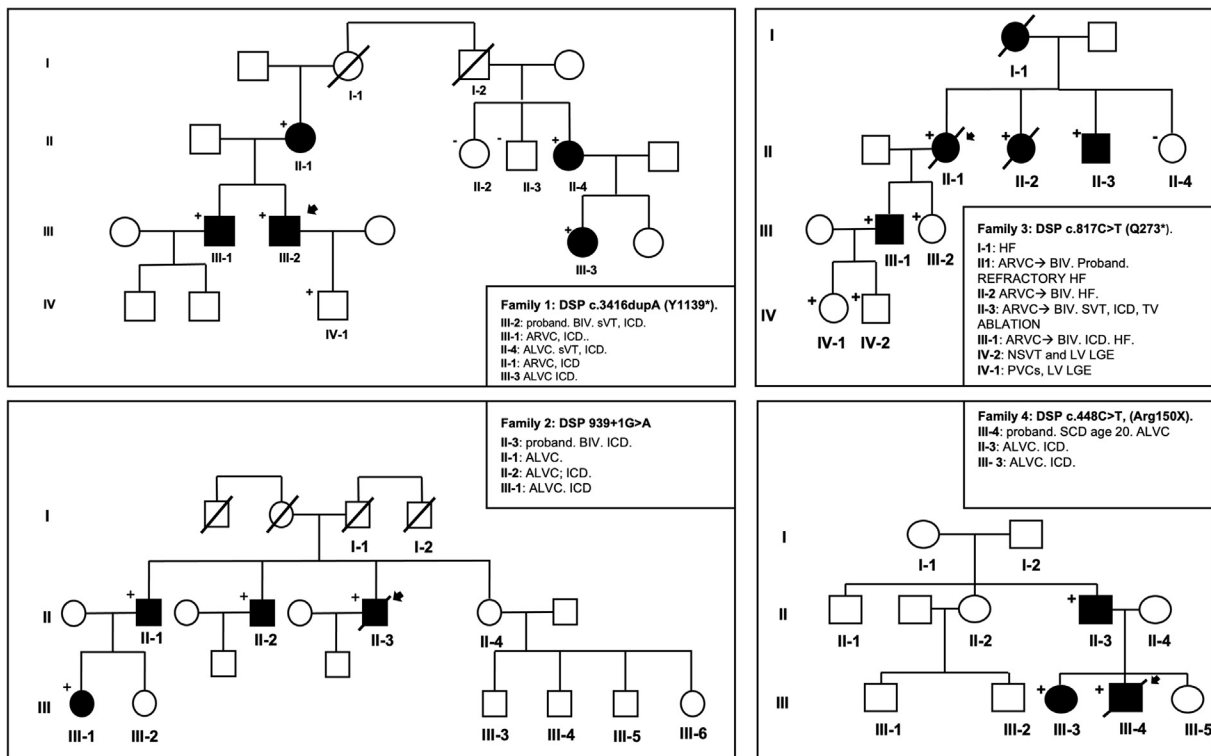

**Figure 2** Family trees of 4 families with a P/LP variant on the DSP gene. Black squares and circles indicate affected males and females, respectively. White squares and circles indicate healthy males and females, respectively. The + sign indicates the presence of the variant in the subject; the arrow indicate the proband; and the crossed-out square or circle indicates that the subject is dead. The corner panels contain brief clinical information, including change in phenotype during follow-up. ARVC arrhythmic right ventricular cardiomyopathy; ALVC = arrhythmic left dominant cardiomyopathy; BIV = biventricular phenotype; DSP = desmoplakin; HF = heart failure; ICD = implantable cardioverter-defibrillator; LGE = late gadolinium enhancement; LV = left ventricle; NSVT = non sustained ventricular tachycardia; P/LP = pathogenic/likely pathogenic; PVCs = premature ventricular contractions; SCD = sudden cardiac death; sVT = sustained ventricular tachycardia.

to the ALVC group ( $P = .001$ ). One female patient was transplanted because of refractory HF at the age of 67 years (Table 3).

Males showed a higher incidence of MVAs (52% vs 24%;  $P = .036$ ), HF episodes (31% vs 3%;  $P = .004$ ), and cardiac death (31% vs 0%;  $P \leq .001$ ) than did females.

In Kaplan-Meier analysis, ARVC forms had a worse event-free survival when compared with the other phenotypic groups regarding death from cardiac causes (log-rank,  $P = .020$ ). No significant difference among the 3 ACM phenotypes was observed regarding HF-free survival (log-rank,  $P = .342$ ). In addition, males appeared to have lower major arrhythmia-free survival than females, although this did not reach a statistical significance (log-rank,  $P = .060$ ).

Regarding MVAs event-free survival analyses (Figure 4), we observed a higher arrhythmic burden in ARVC forms than in disease forms with LV involvement when evaluated from birth (log-rank,  $P = .005$ ) (Figure 4A). Considering only the follow-up period (Figure 4B), a trend of increased arrhythmogenicity in ARVC forms was present, even if the difference among the 4 groups was not statistically significant (log-rank,  $P = .207$ ). The Kaplan-Meier curve (Figure 4C) shows a worse composite outcome in ARVC

forms as compared with ALVC forms (log-rank,  $P = .0374$ ). Patients without a phenotype do not have any major event during follow-up.

**Autopsy findings**

Autopsy was performed in 5 of 8 subjects (63%) who died of cardiac causes, all SCD except 1 with HF. Heart weight ranged from normal values to cardiomegaly (300–760 g). Ventricular chamber dilatation was evident in 3, with RV aneurysms in 2. The LV was involved in all, in the setting of an ALVC pattern in 3 (60%), and BIV in 2 (40%) (Figure 5). Fibrofatty replacement of the LV free wall typically involved the subepicardial and mid-mural layers with transmural extension and wall thinning but no aneurysm formation in 1 of 5 patients (20%). Cardiomyopathic changes were detected in all except 1 (20%) who showed an “infarct-like” band of acute-subacute myocyte necrosis associated with inflammation in the outer mid–subepicardial layer of the posteroseptal and posterolateral walls of the LV, findings consistent with an early stage of disease onset (previously reported).<sup>3</sup> Noteworthy, 1 additional patient (20%) had an endomyocardial biopsy 20 years before detecting active myocarditis.

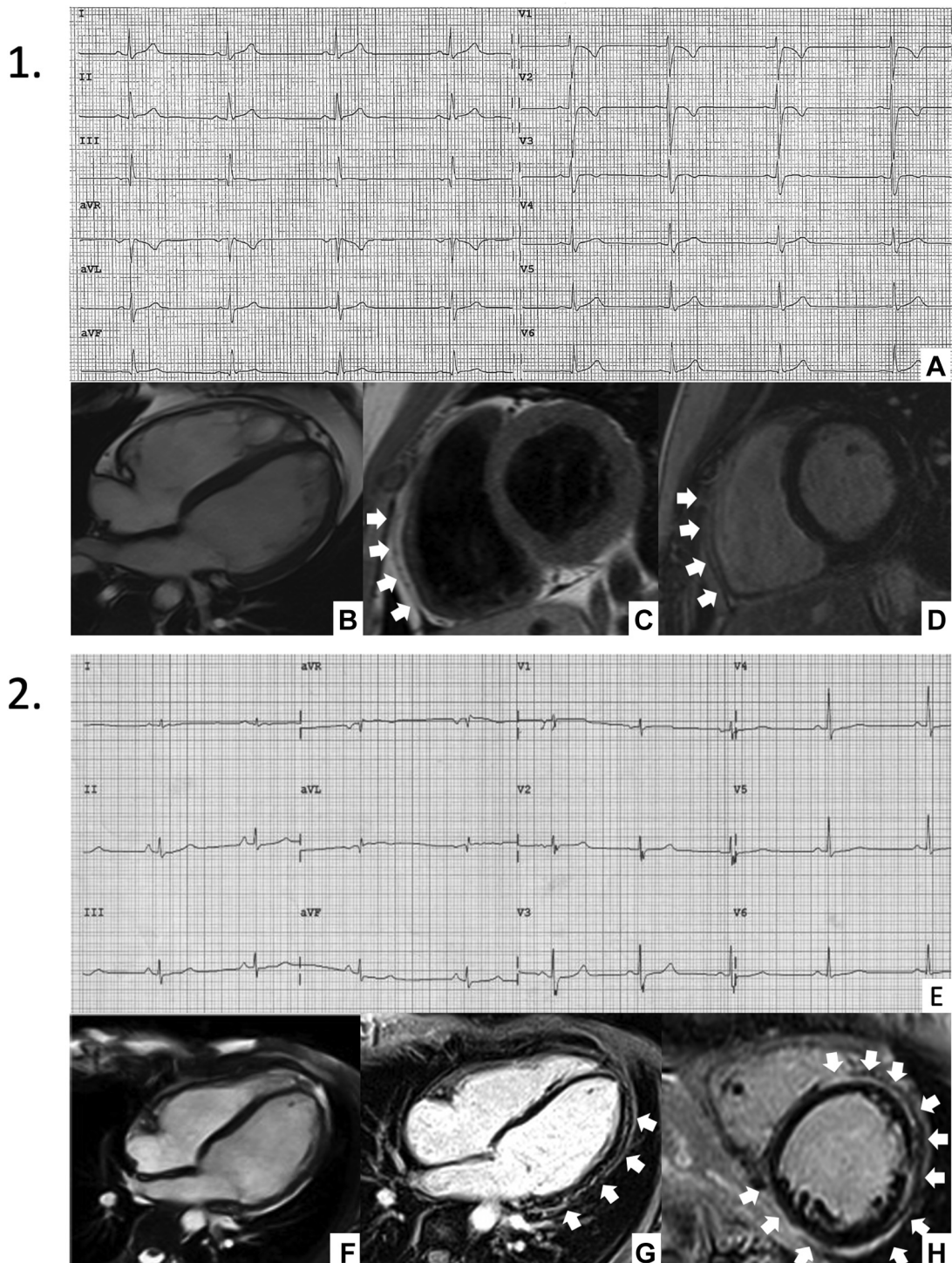

**Figure 3** Phenotypic variability within family 1. **Panel 1:** ECG and CMR of subject III-1. **Panel 2:** Same examinations of subject III-3. In the first patient, ECG demonstrates the presence of TWI from leads V<sub>1</sub>–V<sub>3</sub> (A) and CMR shows mild RV dilatation and moderate dysfunction with anterior and inferior wall akinesia in the mid-apical segments (B); in the same regions, fibrofatty infiltration was present (C and D). In the second patient, ECG shows diffuse low QRS voltages (E) and CMR demonstrates a mild LV dilatation with moderate systolic dysfunction (F). After gadolinium administration, circumferential LGE appeared (G and H). CMR = cardiac magnetic resonance; ECG = electrocardiography; LGE = late gadolinium enhancement; LV = left ventricle; RV = right ventricle; TWI = T-wave inversion.

## Discussion

By analyzing the clinical features and outcome of a consecutive series of patients carrying *P/LP DSP* genetic variants, we evidenced a wide phenotypic spectrum with a prevalence of

LV involvement. However, 16 subjects (22%) showed ARVC fulfilling the 2010 ACM diagnostic criteria, and within the same family, different clinical phenotypes were diagnosed. CMR with tissue characterization confirms its

**Table 2** Instrumental findings of patients with a pathogenic/likely pathogenic variant on the *DSP* gene at the end of follow-up

Variable	Phenotype					P
	Overall (N = 73 [100%])	Unaffected (n = 11 [15%])	ARVC (n = 16 [22%])	ALVD (n = 26 [36%])	BIV (n = 20 [27%])	
TWI V <sub>1</sub> -V <sub>3</sub>	15 (21)	0 (0)	7 (44)	2 (8)	6 (30)	.024
TWI V <sub>4</sub> -V <sub>6</sub>	16 (22)	0 (0)	5 (31)	5 (19)	6 (30)	.174
TWI inf leads	8 (11)	0 (0)	2 (13)	4 (15)	2 (10)	.677
Epsilon wave	2 (3)	0 (0)	2 (10)	0 (0)	0 (0)	.206
LQRS voltages in the precordial leads	13 (18)	0 (0)	2 (13)	6 (23)	5 (25)	.291
LQRS voltages in the limb leads	32 (44)	1 (9)	6 (38)	13 (50)	12 (60)	.037
WMA RV	22 (39)	0 (0)	4 (80)	7 (30)	11 (65)	.012
LGE RV	17 (30)	0 (0)	4 (80)	0 (0)	13 (77)	<.001
EF RV	55 (47-63)	63 (60-67)	46 (43-58)	57 (54-65)	45 (40-54)	<.001
EDV RV	78 (69-103)	69 (55-79)	111 (101-117)	76 (68-86)	83 (82-89)	.002
FAT RV	11 (20)	0 (0)	2 (40)	2 (9)	7 (41)	.046
FAT LV	23 (41)	0 (0)	3 (60)	9 (39)	11 (65)	.093
EDV LV	85 (75-106)	66 (57-80)	83 (82-89)	84 (82-94)	105 (87-120)	.003
EF LV	52 (44-63)	69 (64-77)	56 (55-63)	55 (46-63)	47 (36-53)	.003
WMA LV	25 (45)	0 (0)	2 (40)	11 (48)	12 (71)	.068
LGE LV	40 (72)	0 (0)	2 (40)	21 (91)	15 (88)	.001
LGE LV >2 segments	33 (59)	0 (0)	0 (0)	19 (83)	11 (65)	.012

Continuous variables are expressed as median (25th-75th percentile). Categorical variables as absolute number (percentage).

ALVC = arrhythmogenic left dominant cardiomyopathy; ARVC = arrhythmogenic right ventricular cardiomyopathy; BIV = biventricular; EDV = end-diastolic volume; EF = ejection fraction; inf = inferior; LGE = late gadolinium enhancement; LQRS = low QRS; LV = left ventricle; RV = right ventricle; TWI = T-wave inversion; WMA = wall motion alteration.

fundamental role in ALVC variant diagnosis. The adoption of ACM Padua criteria in this cohort was able to significantly increase the number of definite diagnoses. Finally, in our series, subjects with ARVC and BIV phenotypes had a significant higher incidence of HF than did those with ALVC, the latter being characterized by a lower degree of electrical instability.

### DSP genetic variants and cardiomyopathies

Studies on genotyped subjects with ACM demonstrated that compared with other desmosomal gene carriers, P/LP *DSP* variant carriers were considerably more likely to develop both HF and signs of LV involvement.<sup>7,12</sup> Taking into consideration the wide clinical phenotype of patients carrying P/LP *DSP* variants, we divided our cohort into 3 groups according to ventricular systolic function: ARVC, ALVC, and BIV. Moreover, we assessed the usefulness of ACM Padua criteria by applying them to our cohort

and found that they were able to significantly increase the number of definite diagnoses. This result suggests that the modified ACM criteria, which have been created taking into consideration the ACM wide clinical spectrum, play a crucial role in the clinical assessment of P/LP *DSP* variant carriers even if a higher sensitivity for identifying patients with HF and VA outcome was not investigated so far.

### Intrafamilial clinical variability in P/LP *DSP* variant carriers

Many patients showed LV involvement (26 [36%] ALVC and 20 [27%] BIV), thus confirming the association (even if not exclusive) between P/LP *DSP* variants and LV abnormalities. An intrafamilial variability in terms of disease phenotype was also observed. While the progression of an ARVC to a BIV variant is already known to be common

**Table 3** Outcome of patients with a pathogenic/likely pathogenic variant on the *DSP* gene

Variable	Phenotype					P
	Overall (N = 73 [100%])	Unaffected (n = 11 [15%])	ARVC (n = 16 [22%])	ALVC (n = 26 [36%])	BIV (n = 20 [27%])	
MVAs	21 (29)	0 (0)	9 (56)	4 (15)	8 (40)	.002
Death for cardiac causes	8 (13)	0 (0)	5 (31)	1 (4)	2 (10)	.009
Heart failure	6 (8)	0 (0)	2 (25)	0 (0)	4 (20)	.001

Categorical variables are expressed as absolute number (percentage).

ALVC = arrhythmogenic left dominant cardiomyopathy; ARVC = arrhythmogenic right ventricular cardiomyopathy; BIV = biventricular; MVAs = major ventricular arrhythmias.

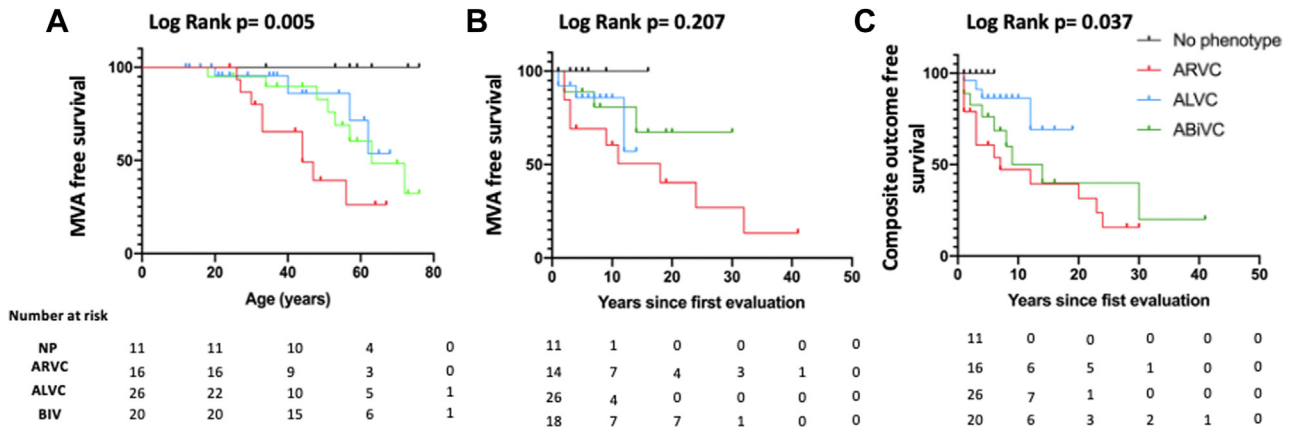
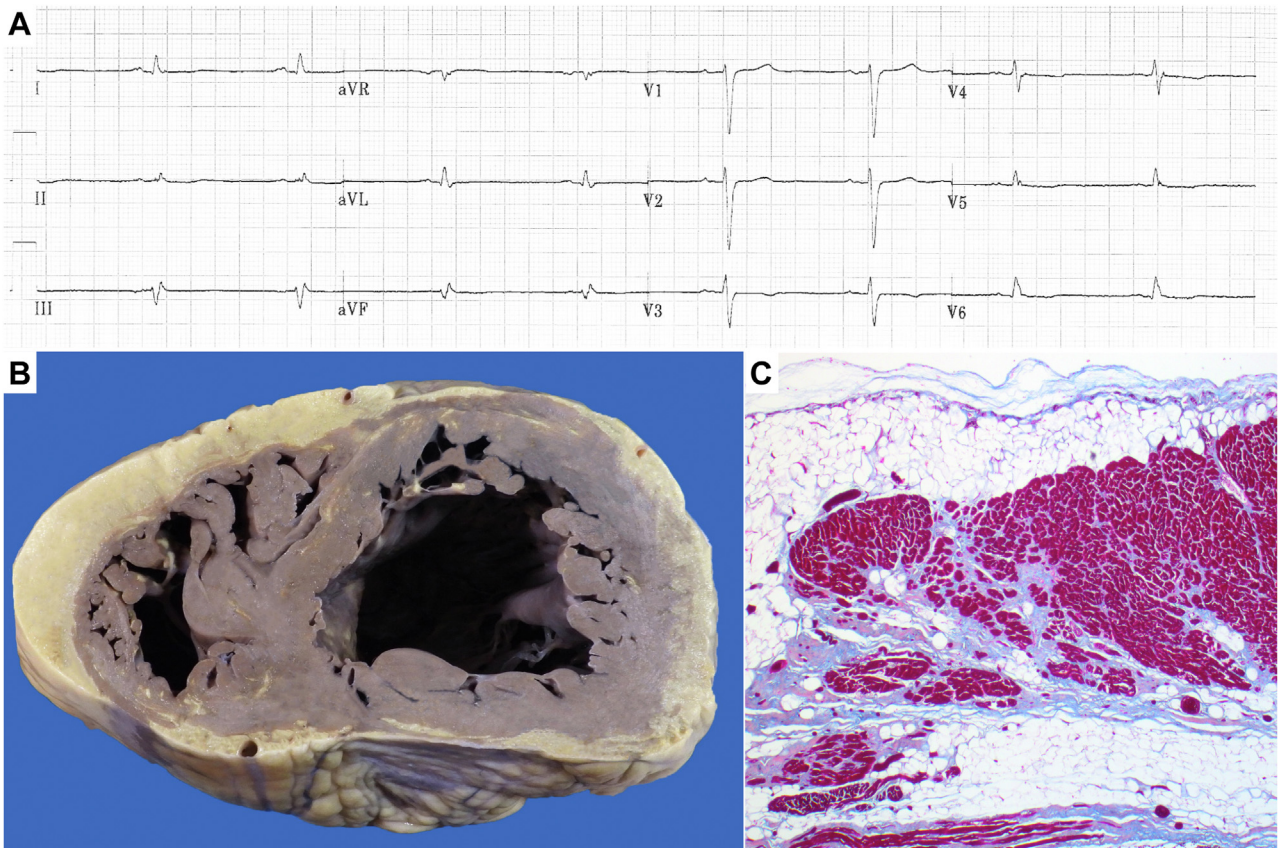

**Figure 4** Kaplan-Meier analysis. **A:** MVA-free survival from birth. **B:** MVA-free survival from the first clinical evaluation is considered. **C:** Composite outcome-free survival. The description is reported in the text. ALVC = arrhythmic left dominant cardiomyopathy; ARVC = arrhythmic right ventricular cardiomyopathy; BIV = biventricular phenotype; MVA = major ventricular arrhythmia; NP = no phenotype.

in ACM natural history, the coexistence of ALVC and ARVC forms even within variant carriers belonging to the same family raises the issue of modifying factors and genes that are not completely known up to now (Figures 2 and 3).<sup>13–18</sup>

### CMR findings and disease diagnosis

A CMR study with use of contrast agent has a pivotal role in the diagnosis of cardiomyopathies. Recently, Smith et al<sup>7</sup> proposed the term “desmoplakin cardiomyopathy” describing a clinical phenotype characterized by a large



**Figure 5** Patient II-3, family 2 with biventricular variant. **A:** ECG demonstrated the presence of TWI from leads V<sub>3</sub>–V<sub>6</sub> and inferior leads with diffuse low QRS voltages. **B:** Gross analysis of the heart at autopsy: at transverse section, evidence of almost circumferential LV yellow appearance of the subepicardial layer. **C:** Histological confirmation of fibrofatty replacement of the myocardium in the subepicardium of the LV wall (Heidenhain trichrome, original magnification  $\times 20$ ). ECG = electrocardiography; LV = left ventricular; TWI = T-wave inversion.



amount of LV fibrosis, episodes of myocardial necrosis, and a significant degree of electrical instability. However, this definition applied to our series was able to describe only 26 (36%) of clinically affected patients, in contrast to the study by Smith et al, which had 51% of patients with an ALVC form. Indeed, RV morphological features fulfilling a diagnosis of a “classical” ACM phenotype were present in 16 (22%) subjects. The fundamental role of CMR in ACM diagnosis was recently emphasized by our group with the inclusion of LGE results in the Padua criteria.<sup>4,10,19</sup>

### Disease progression and outcome

In our cohort, 20 (27%) patients were classified in a different phenotypic group compared to the first evaluation. The most common change was from “no phenotype” to ALVC, with detection in the majority of newly diagnosed cases of LV-LGE in the absence of LV dilatation. This could suggest that in these patients, the LV is the first chamber to be involved, with tissue abnormalities preceding chamber dilation and dysfunction.

Furthermore, 21 (29%) patients showed MVAs. The analysis of MVAs-free survival demonstrated a higher incidence of electrical instability in ARVC forms (Figure 4A) when considering patients’ whole life, while in follow-up examination (Figure 4B) a significant difference was not found, probably reflecting the role of therapy. Finally, evaluation of the composite outcome-free survival (Figure 4C) found the presence of a significant worse trend in patients with RV involvement. Recently, Wang et al<sup>12</sup> analyzed 91 P/LP *DSP* variant carriers and found that LV EF < 35% and RV dysfunction were prognostic for sustained VA. Even if the 2 cohorts are different in the number of probands, phenotypic classification, and follow-up duration, these features on LV and RV function are usually in keeping with BIV and ARVC forms, thus confirming the higher risk of MVAs in these patients.<sup>12</sup> Noteworthy, according to Smith et al, all patients with ALVC with MVAs showed normal or mildly decrease LV systolic function, underlying the poor prognostic role of this parameter in contrast to other cardiomyopathies such as DCM. During follow-up, 11% experienced HF with similar incidence in ARVC and BIV variants. Remarkably, no subject belonging to the ALVC group experienced HF. Wang et al<sup>12</sup> found that myocardial injury has recently been associated with an increased incidence of HF. However, in our population, no HF episodes were observed in patients with previous myocarditis.

### Role of sex

It is noteworthy that in our cohort, females were more commonly diagnosed as having LV involvement, consisting with both ALVC and BIV forms, than males, who more frequently showed an ARVC variant. This confirms previous observations on male prevalence in the “classical” ACM form. Furthermore, a female prevalence in P/LP variant *DSP* carriers with ALVC has been previously described.<sup>7</sup>

Regarding disease outcome, males showed a significantly higher incidence of MVAs, HF, and cardiac death than did females. This confirms previous data on both patients with ACM and those with DCM.<sup>20,21</sup>

### Conclusion

The phenotypic spectrum in subjects carrying P/LP *DSP* variants is wide in terms of both morphological abnormalities and the degree of electrical instability. Although the majority of patients show LV involvement, 16 (22%) have RV abnormalities in keeping with the diagnosis of “classical” ACM. In P/LP *DSP* variant carriers with an ALVC phenotype, HF episodes and MVAs seem to be less common as compared with other phenotypic forms with RV involvement. LV systolic function cannot be considered a valuable parameter to predict arrhythmic risk. Sex seems to play a role in the variable phenotype of P/LP *DSP* variant carriers.

### Appendix Supplementary data

Supplementary data associated with this article can be found in the online version at <https://doi.org/10.1016/j.hrthm.2022.04.015>.

### References

1. Norgett EE, Hattell SJ, Carvajal-Huerta L, et al. Recessive mutation in desmoplakin disrupts desmoplakin-intermediate filament interactions and causes dilated cardiomyopathy, woolly hair and keratoderma. *Hum Mol Genet* 2000; 9:2761–2766.
2. Rampazzo A, Nava A, Malacrida S, et al. Mutation in human desmoplakin domain binding to plakoglobin causes a dominant form of arrhythmogenic right ventricular cardiomyopathy. *Am J Hum Genet* 2002;71:1200–1206.
3. Bauce B, Basso C, Rampazzo A, et al. Clinical profile of four families with arrhythmogenic right ventricular cardiomyopathy caused by dominant desmoplakin mutations. *Eur Heart J* 2005;26:1666–1675.
4. Sen-Chowdhry S, Syrris P, Prasad SK, et al. Left-dominant arrhythmogenic cardiomyopathy: an under-recognized clinical entity. *J Am Coll Cardiol* 2008; 52:2175–2187.
5. López-Ayala JM, Gómez-Milanés I, Sánchez Muñoz JJ, et al. Desmoplakin truncations and arrhythmogenic left ventricular cardiomyopathy: characterizing a phenotype. *Europace* 2014;16:1838–1846.
6. Heliö K, Kangas-Kontio T, Weckström S, et al. *DSP* p.(Thr2104Glnfs\*12) variant presents variably with early onset severe arrhythmias and left ventricular cardiomyopathy. *BMC Med Genet* 2020;21:19.
7. Smith ED, Lakdawala NK, Papoutsidakis N, et al. Desmoplakin cardiomyopathy, a fibrotic and inflammatory form of cardiomyopathy distinct from typical dilated or arrhythmogenic right ventricular cardiomyopathy. *Circulation* 2020; 141:1872–1884.
8. Marcus FI, McKenna WJ, Sherrill D, et al. Diagnosis of arrhythmogenic right ventricular cardiomyopathy/dysplasia. *Circulation* 2010;121:1533–1541.
9. Corrado D, Perazzolo Marra M, Zorzi A, et al. Diagnosis of arrhythmogenic cardiomyopathy: the Padua criteria. *Int J Cardiol* 2020;319:106–114.
10. Bariani R, Cipriani A, Rizzo S, et al. ‘Hot phase’ clinical presentation in arrhythmogenic cardiomyopathy. *Europace* 2021;23:907–917.
11. Pilichou K, Mancini M, Rigato I, et al. Nonischemic left ventricular scar: screen the genes, scan the mutation carriers. *Circulation* 2014;130:e180–e182.
12. Wang W, Murray B, Tichnell C, et al. Clinical characteristics and risk stratification of desmoplakin cardiomyopathy. *Europace* 2022;24:268–277.
13. James CA, Bhonsale A, Tichnell C, et al. Exercise increases age-related penetrance and arrhythmic risk in arrhythmogenic right ventricular dysplasia/cardiomyopathy-associated desmosomal mutation carriers. *J Am Coll Cardiol* 2013; 62:1290–1297.

14. Zorzi A, Cipriani A, Bariani R, Pilichou K, Corrado D, Bauce B. Role of exercise as a modulating factor in arrhythmogenic cardiomyopathy. *Curr Cardiol Rep* 2021;23:57.
15. Bauce B, Frigo G, Marcus FI, et al. Comparison of clinical features of arrhythmogenic right ventricular cardiomyopathy in men versus women. *Am J Cardiol* 2008;102:1252–1257.
16. Akdis D, Saguner AM, Shah K, et al. Sex hormones affect outcome in arrhythmogenic right ventricular cardiomyopathy/dysplasia: from a stem cell derived cardiomyocyte-based model to clinical biomarkers of disease outcome. *Eur Heart J* 2017;38:1498–1508.
17. Cason M, Celegnin R, Marinas MB, et al. Novel pathogenic role for galectin-3 in early disease stages of arrhythmogenic cardiomyopathy. *Heart Rhythm* 2021; 18:1394–1403.
18. Bueno Marinas M, Celegnin R, Cason M, Thiene G, Basso C, Pilichou K. The role of microRNAs in arrhythmogenic cardiomyopathy: biomarkers or innocent bystanders of disease progression? *Int J Mol Sci* 2020; 21:6434.
19. Marra MP, Leoni L, Bauce B, et al. Imaging study of ventricular scar in arrhythmogenic right ventricular cardiomyopathy. *Circ Arrhythm Electrophysiol* 2012; 5:91–100.
20. Fairweather D, Cooper LT, Blauwet LA. Sex and gender differences in myocarditis and dilated cardiomyopathy. *Curr Probl Cardiol* 2013; 38:7–46.
21. Bazoukis G, Letsas KP, Thomopoulos C, et al. Predictors of adverse outcomes in patients with arrhythmogenic right ventricular cardiomyopathy: a meta-analysis of observational studies. *Cardiol Rev* 2019;27:189–197.