



Status and challenges for the concept design development of the EU DEMO Plant Electrical System

E. Gaio^{a,*}, A. Ferro^a, A. Lampasi^b, A. Maistrello^a, M. Dan^a, M.C. Falvo^c, F. Gasparini^a, F. Lunardon^a, A. Magnanimo^e, M. Manganelli^c, S. Minucci^d, S. Panella^c, M. Proietti Cosimi^c, D. Ratti^a, L. Barucca^f, S. Ciattaglia^g, T. Franke^{e,g}, G. Federici^h, R. Piovan^a

^a Consorzio RFX (CNR, ENEA, INFN, Università di Padova, Acciaierie Venete S.p.A.), Padova 35127, Italy

^b ENEA Frascati, Frascati, Rome 00044, Italy

^c Department of Astronautic, Electrical and Energy Engineering, Sapienza University of Rome, 00184 Rome Italy

^d Department of Economics, Engineering, Society and Business Organization, University of Tuscia, Viterbo 01100, Italy

^e Max-Planck-Institut für Plasmaphysik, Garching 85748, Germany

^f Ansaldo Nucleare, Genova 16152, Italy

^g EUROfusion Consortium, Boltzmannstrasse 2, Garching, Germany

^h Fusion for Energy, Boltzmannstr.2, Garching 85748, Germany

ARTICLE INFO

Keywords:

EU DEMO
Plant Electrical System
Net power
Recirculation power
Electrical technologies
Advanced power converters
Electrical energy storage
Power quality

ABSTRACT

The EU DEMO Plant Electrical System (PES) main scopes are to supply all the plant electrical loads and to deliver to the Power Transmission Grid (PTG) the net electrical power generated. The studies on the PES during the Pre-Concept Design (PCD) Phase were mainly addressed to understand the possible issues, related to the special features both of the power generated, with respect to a power plant of the same size, and of the power to be supplied to the electrical loads. For this purpose, the approach was to start the design of the different PES components adopting technologies already utilized in fusion experiments and in Nuclear Power Plants (NPP) to verify their applicability and identify possible limits when scaled to the DEMO size and applied to the specific pulsed operating conditions. This work is not completed, however several issues have been already identified related to the pulsed operation of the turbine generator, the large amount of recirculation power, the very high peaks of active power required for the plasma formation and control, the huge reactive power demand, if thyristor converter technology was adopted to supply the superconducting coils, etc.. The paper gives an overview on the features and scope of the PES and its subsystems, on the main achievements during the Pre-Concept Design (PCD) Phase, on the challenges for the development of the conceptual design in the next framework program and on the plan to face them.

1. Introduction

In the frame of the integrated design development of the EU DEMO [1], the Plant Electrical System (PES) is composed of the subsystems and components serving to provide the needed electrical power to the plant electrical loads and to deliver the generated net electrical power to the Power Transmission Grid (PTG).

The PES is highly interrelated with other plant systems; Fig. 1 shows the main interfaces. Different options are under development for the DEMO key core parts; the impact of some of them, like: breeding blanket (BB) heat transfer system [2,3], magnets [4], plasma control [5], heating and current drive (HCD) systems [6], on the requirements for the PES

design is very strong. Thus, an integrated approach is needed.

This paper gives an overview on the features and scope of the PES and its subsystems and components, on the main achievements during the DEMO Pre-Concept Design (PCD) Phase, on the challenges for the Concept Design (CD) development and on the plan to face them.

2. The plant electrical system

The PES has been divided into five main subsystems, as shown in the block scheme of Fig. 2, which also sketches the subsystems function and links among them.

The yellow box represents the Turbine Generator (TG), which

* Corresponding author.

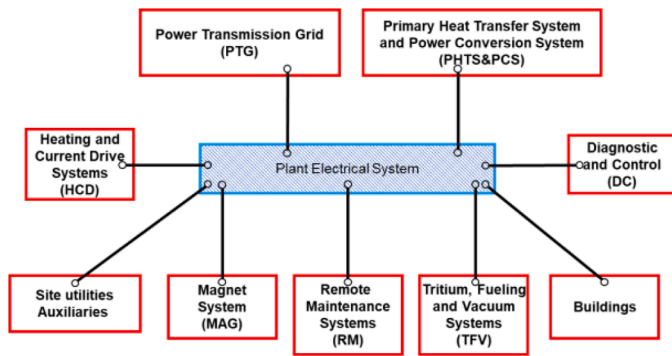

Fig. 1. Main PES interfaces with other DEMO systems.

produces the gross electrical power, part of which will be recirculated to supply the plant electrical loads.

The green box represents the High Voltage electrical Network (HVN), providing the transmission of high voltage (HV – higher than 30 kV) within the plant and the delivery to the external Power Transmission Grid (PTG) of the net electrical power, resulting from the gross electrical power minus the recirculation power to supply the plant electrical loads.

The violet block includes the components of the medium voltage and low voltage electrical network (MLVNE) to provide the relevant electrical power to the plant electrical loads, according to their classification. The MLVNE also includes the emergency power supplies (EmPS).

The electrical loads are classified in the following categories according to the functions associated to the supplied systems:

- Ordinary electrical Loads (OL): their loss will not cause safety or investment protection issues. They are supplied by Class IV (Table 1 -

Table 1
Supply classes for steady state load.

Class I	the dc power is warranted by uninterrupted power supply (UPS) for few hours, also in case of LOOSP* and class III failure (Station Blackout)
Class II	the ac power is provided (UPS) for few hours, also in case of LOOSP* and class III failure (Station Blackout)
Class III	the ac power supply can be lost for a short period, i.e. tens of sec
Class IV	the ac power can be lost for long periods, up to 32 h, e.g. for a serious LOOSP*

* LOOSP Loss Of Off Site Power [7].

supply classes for steady state load)

- Safety Important Class (SIC) Structures, Systems and Components (SSC): their loss might cause a nuclear safety issue. They are supplied by the relevant classes I, II, III, designed according to the safety requirements for SIC electrical loads (see 3.4.3).
- Investment Protection (IP) electrical loads: their loss will cause an IP issue. They are supplied by the relevant classes I, II, III.

The blue box represents the Coil Power Supply (CPS) system devoted: to supply the needed voltage and current to the Superconducting (SC) coils [4] for the plasma formation during the breakdown phase and the subsequent plasma current rise, and its sustainment and control during the pulse; to provide the fast discharge of SC coils; to supply non SC coils and in-vessel coils, if provided in DEMO; this will be defined in the CD phase.

Fig. 3 shows a sketch of the plasma pulse with the main phases indicated.

Finally, the red box includes the components for the supply of the devices for HCD system [6].

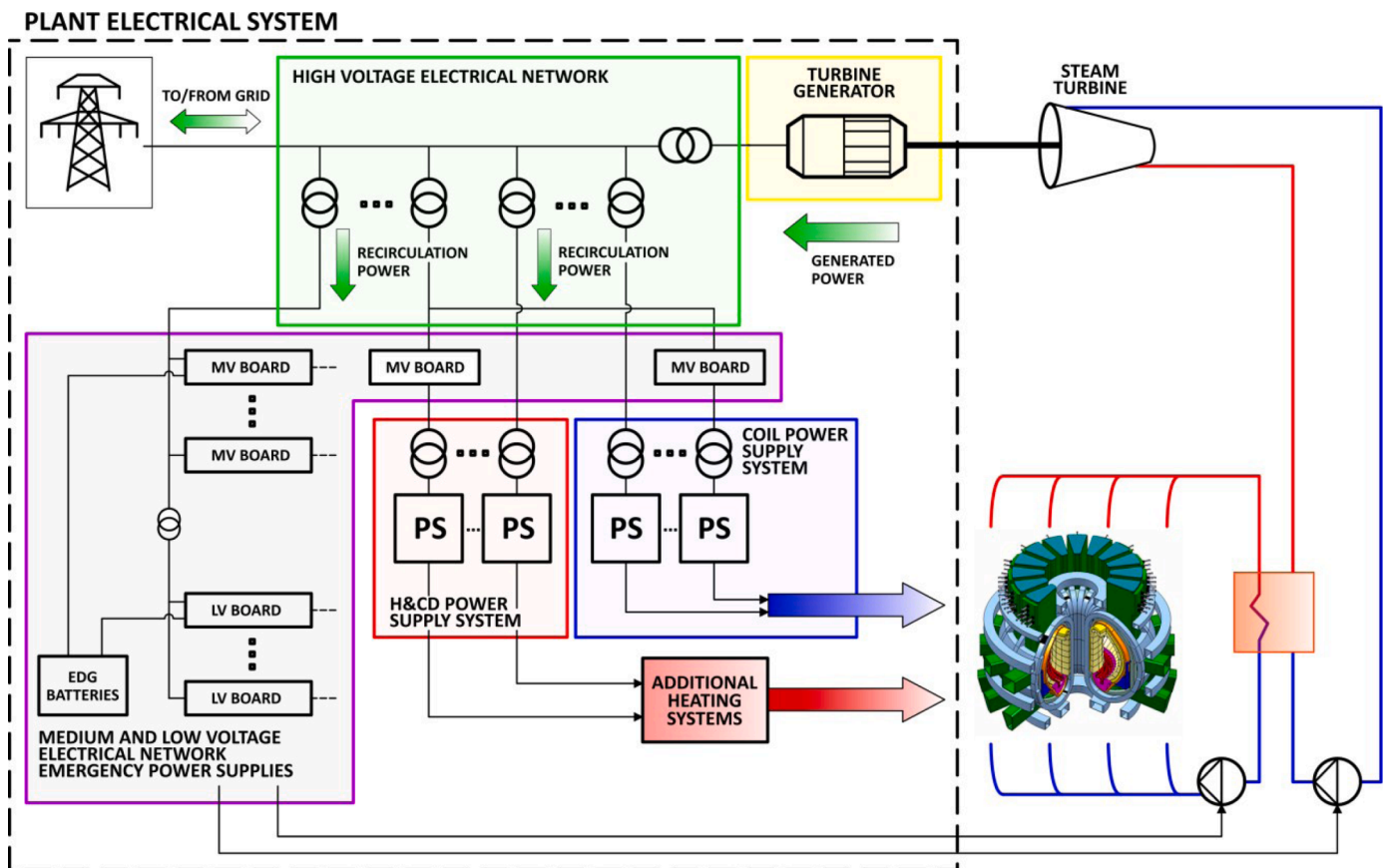

Fig. 2. Simplified block scheme of the DEMO PES with subsystems highlighted, (EDG is Emergency Diesel Generator, PS is Power Supply, HV, MV, LV are High Voltage, Medium Voltage and Low Voltage).

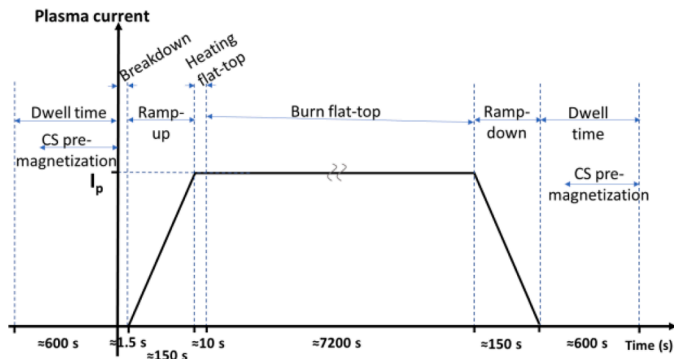

Fig. 3. Sketch of plasma pulse indicating the main phases.

3. Design and R&D status at the end of the PCD Phase

The studies on the PES during the PCD Phase were concentrated in particular to understand the requirements, to identify main issues and to start exploring solutions [8].

The study approach, to be continued in the next CD phase, is described in the flow-chart in Fig. 4.

The first step is focused on the study and understanding of the power needs of the plant electrical loads, which present very special features, on the different TG operating conditions, and on the issues related to the interface with the PTG.

The initial design was started adopting the technologies utilized in ITER, where applicable, and in Nuclear Power Plant (NPP) for the non-

fusion parts of the plant. Although preliminary, this work enabled the identification of the limits of some design solutions when scaled to the DEMO size and to identify some issues.

The next section reports the status of the work done in the PCD Phase, starting from the CPS components, since they generate issues that impact on the upstream power system. Research and Development (R&D) work to face them, already launched and planned for the CD phase, is described in Section 4.

3.1. ITER-like design of the CPS

Since the largest and fastest power transients are caused by pulsed power in the SC coils for plasma formation and control, the work was first addressed to estimate them, by assuming ITER-like circuit topologies and technologies for the relevant power supply systems of poloidal circuit [9].

3.1.1. The poloidal circuits

The poloidal circuits of DEMO are shown in Fig. 5. Each central solenoid (CS) and poloidal (PF) coil is fed by a dedicated Base Converter (BC), with the exception of CS1U and CS1L, connected in series and fed by the same couple of converters.

The nominal current of the CS and PF coils were not yet fixed, thus the values of Table 2 were agreed within the DEMO team to be assumed for all the BCs currents. The tentative on-load voltage ratings have been derived from the needs for plasma formation during breakdown and ramp-up phases (± 6 kV and ± 9 kV respectively), with some margin [10]. They are 2–3 times higher than the on-load voltage of the corresponding ITER base converters (Table 2).

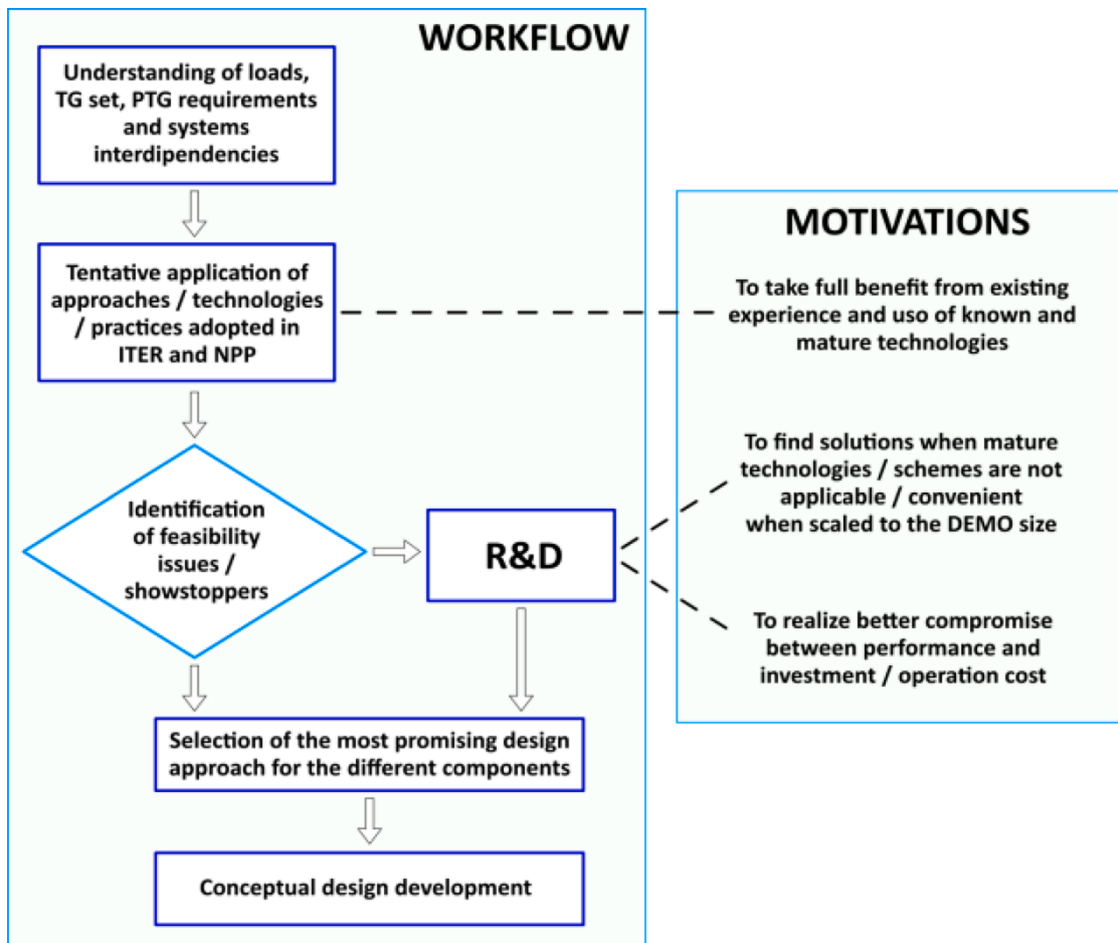

Fig. 4. Overview of the approach to the studies to be continued in the CD phase.

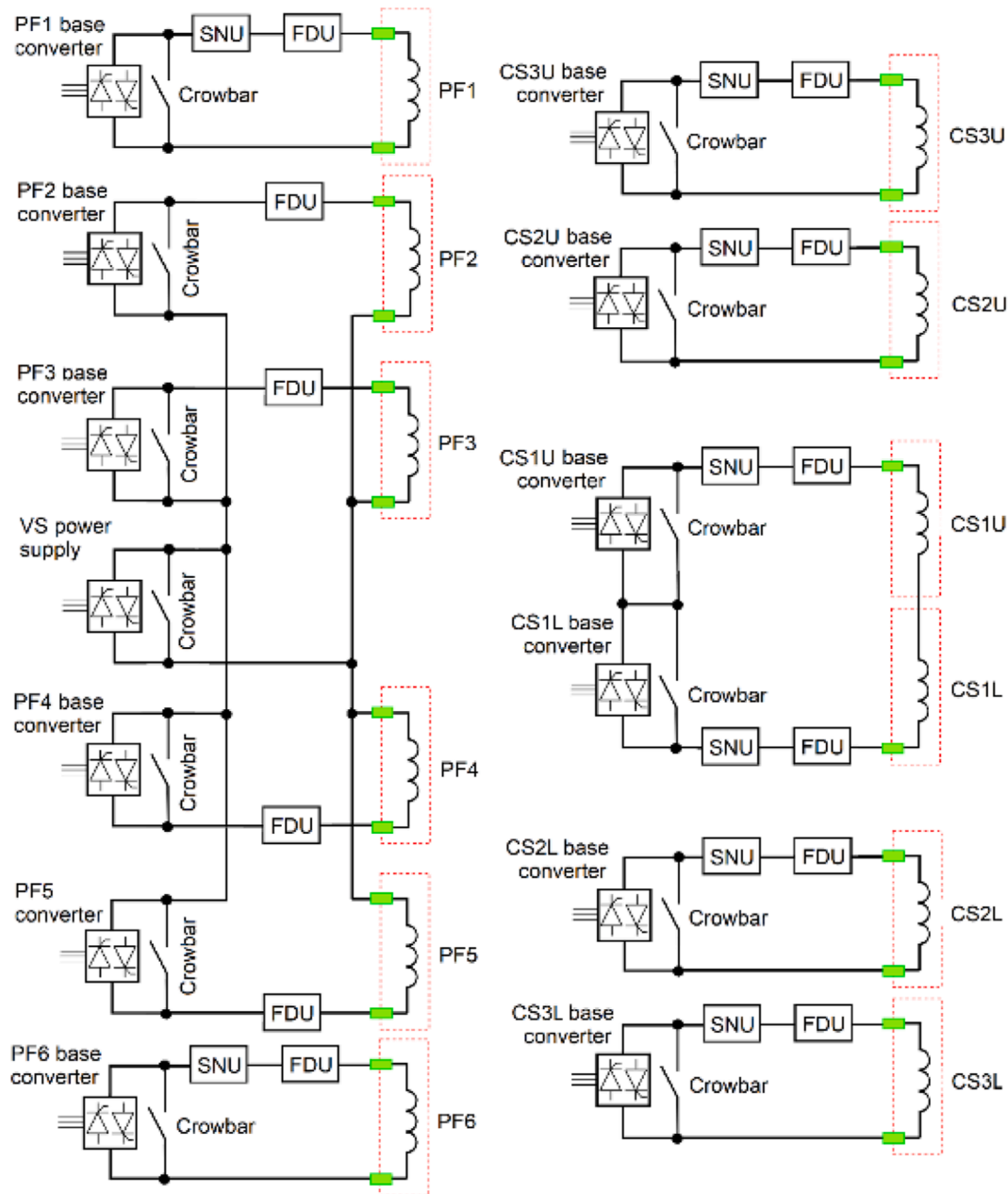

Fig. 5. ITER-like circuits for DEMO CS and PF Coils.

Table 2
Tentative BC ratings for CS and PF coils in comparison with ITER ones.

SC coils	DEMO voltage rating*	DEMO current rating	ITER voltage rating*	ITER current rating
CS1U, CS1L, CS2U, CS2L, CS3U, CS3L	±8 kV	±45 kA	±2.1 kV	±45 kA
PF1, PF6				±55 kA
PF2, PF3, PF4, PF5	±10 kV		±3.15 kV	

* on load, coil terminal to terminal voltage.

A Vertical Stabilization (VS) converter is foreseen, providing the voltage required for vertical stabilization of the plasma. For this, a provisional voltage rating was considered in the PCD Phase (± 6 kV), while current rating and dynamic requirements are still to be defined.

At plasma breakdown and ramp-up, additional voltage not requiring fine regulation is provided to all the CS coils, PF1 and PF6, by Switching Network Units (SNU), composed of resistors inserted in series to the poloidal coils and bypassed at the proper time. In this way, no active power is required from the ac side. The same scheme of the ITER SNUs [11] could be applicable also to DEMO. The rated voltage has tentatively fixed to 10 kV for all the SNUs, considering a margin ranging in $[0 \div 2$ kV] with respect to the values resulting from the plasma breakdown scenarios, in the range $8 \div 10$ kV.

The design study gave also inputs for the DEMO plant integrated layout; details can be found in [12]. The estimation of the overall area for CS and PF converters and Reactive Power Compensation and Harmonic Filtering (RPC&HF) System is summarized in Table 3 and described in more detail in [10].

3.1.2. Power profiles

Simulink® models were developed to estimate the amount of active

Table 3
Overall area estimation of DEMO PF/CS BCs and RPC&HF system.

	CS and PF converters		RPC&HF system	
	Indoor [m ²]	Outdoor [m ²]	Indoor [m ²]	Outdoor [m ²]
ITER	5780	3644	819	8408
DEMO	14,023	11,075	2590	26,587

and reactive power demand using thyristor converters to supply CS and PF coils [10]. Fig. 6 shows the active power profiles related to CS and PF BCs, calculated in the DEMO breakdown phase for the two plasma scenarios studied [13,14], giving the minimum and maximum active power peak.

The results also revealed that the power utilization factor of the coil PS (ratio between the maximum active power and the installed one that can be derived from Table 2) is extremely low; it is related to the fact that the maximum current and voltage are not contemporary required in all the circuits. This is another issue that needs to be assessed, also exploring possible optimization of requirements.

Fig. 7 shows the active and reactive power profiles, related to CS and PF BCs and calculated in the whole DEMO pulse for the plasma scenarios requiring the minimum active power peak. The power for the HCD systems has to be added to these profiles; in particular, during the flat-top phase, power transients are expected as indicated in [5]. The results showed that the reactive power demand would be enormous (more than 2 Gvar), also when mitigated with the typical Q-reduction control strategies, like the sequential control of series-connected units adopted in ITER, or the introduction of a bypass switch at the output of each unit. Fig. 8 shows that the reactive power level resulting at the plasma breakdown is about a factor of 3 times that of ITER.

The issues in terms of active power peaks and the huge reactive demand are evident; the second one is mainly related to the need of high current and low voltage values in large part of the plasma pulse and shows that thyristor converters do not seem so suitable to supply SC coils, when scaled to the DEMO size.

3.2. Issues on fast discharge of superconducting coils

To discharge quickly the coils in the case of a quench and whenever necessary, Fast Discharge Units (FDUs) are provided in series to each coil; they are composed of Circuit Breakers (CB) to interrupt the coil current and transfer it to proper Dump Resistor (DR) to discharge the stored energy (principle scheme inside the red box of Fig. 10). To be noted that the current in the FDU CBs lasts all the coil operation time

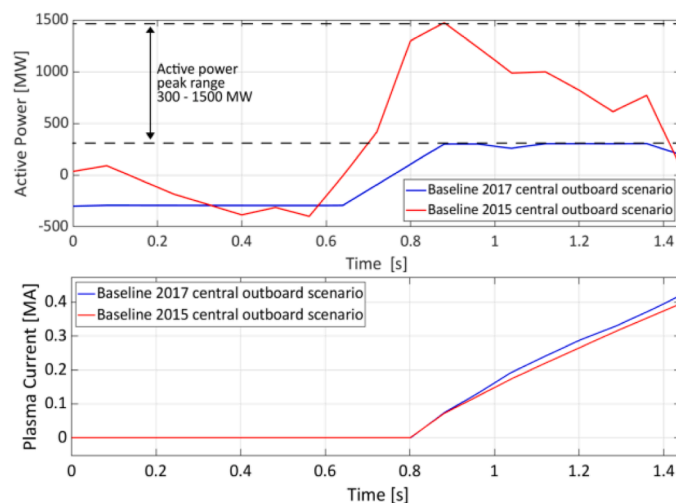

Fig. 6. Active power profiles related to CS and PF BCs calculated for two plasma scenarios at the plasma breakdown.

(continuous for TF coils and equal to the pulse length (~ 2 h) for CS and PF coils), while in DRs only during the current dump; this implies smaller size for cable/busbars connecting the CBs to the DRs.

The work done in the PCD Phase was mainly concentrated on the FDU of TF coils. In DEMO the TF coils are 16; they can be grouped in sectors of coils in series, each one interleaved with one FDU. Fig. 9 shows the case with 16 sectors and as many FDUs and couples of feeders.

The need to reduce the size of penetrations in the tokamak building suggests locating the FDU CBs as close as possible to the coils; however, the environmental conditions are not suitable for electrical and electronic components due to the presence of dc stray magnetic field and nuclear irradiation. This aspect represents one of the main issues related to the FDU design and has to be taken into account since the very beginning, starting a close coordination and integration with teams responsible of the layout development, definition of room conditions in the areas where the TF FDU could be located and design of nuclear shielding. A first step in the PCD Phase was to estimate the footprint of the TF coil FDUs components to be installed in the tokamak building scaling from ITER (for 16 coil sectors, the total footprint is around 176 m²) and to start jointly analyzing the layout.

Another important issue is related to the need to limit the coil terminal to terminal and terminal to ground voltage at the current dump. The terminal to ground voltage of each TF FDU mainly depends on the number of sectors; thus, the voltage limitation is a contrasting requirement with respect to the reduction of the feeders number.

The 8 sectors case (two coils in series per sector, like in ITER) was explored to halve the number of penetrations through the tokamak building, with consequent reduction of power losses and a great simplification of the layout. To better quantify the implications in terms of voltage and judge the feasibility, specific analyses have been performed [15].

3.2.1. Circuitual studies to estimate coil peak voltages

The evolution of the transient voltages at the coil current dump and in fault conditions strongly depend on the circuit topology, on the FDU requirements and design, and also on stray circuitual parameters; therefore, studies on TF circuit and a tentative design of FDU were performed to estimate the peak voltages in the different conditions. Among different schemes analysed, two solutions have been considered for the earth connection of the TF circuit (Fig. 10).

Both schemes allow halving the terminal to ground voltage with respect to the terminal to terminal voltage, in case of normal fast discharge. To better evaluate the relative merit of A and B topologies in terms of transient peak voltage values, further analyses should be done, taking also into account the impact of circuit stray parameters.

3.2.2. FDU first design for layout studies and estimation of coil peak voltages

Several winding packs are under study for DEMO TF coils, with different values of currents and total coil inductance [4]. The values assumed for the design, labelled as Baseline 2018, are summarised in Table 4, where also the other data assumed for a first ITER-like design of DEMO TF FDUs are summarized. The limits in terms of maximum TF coils terminal to terminal and terminal to ground voltages at current dump are 10 kV and 5 kV, respectively [4].

In ITER, the FDUs have been designed for a value of energy corresponding to the energy stored in the TF coils minus the energy dissipated in the structures surrounding the coils (in particular: the coil cases, radial plates and vacuum vessel) during the FDU intervention. This value is not negligible, being around 15% of the total energy. However, since the geometry of the passive structures of DEMO is not finalized yet, this effect could not be simulated. Therefore, for DEMO the FDU discharge resistors have been supposed to dissipate all the energy stored in the coils, being aware that this is a too conservative assumption that will be corrected in the following CD phase.

A simplified scheme of an ITER-like FDU [16] is shown in Fig. 11.

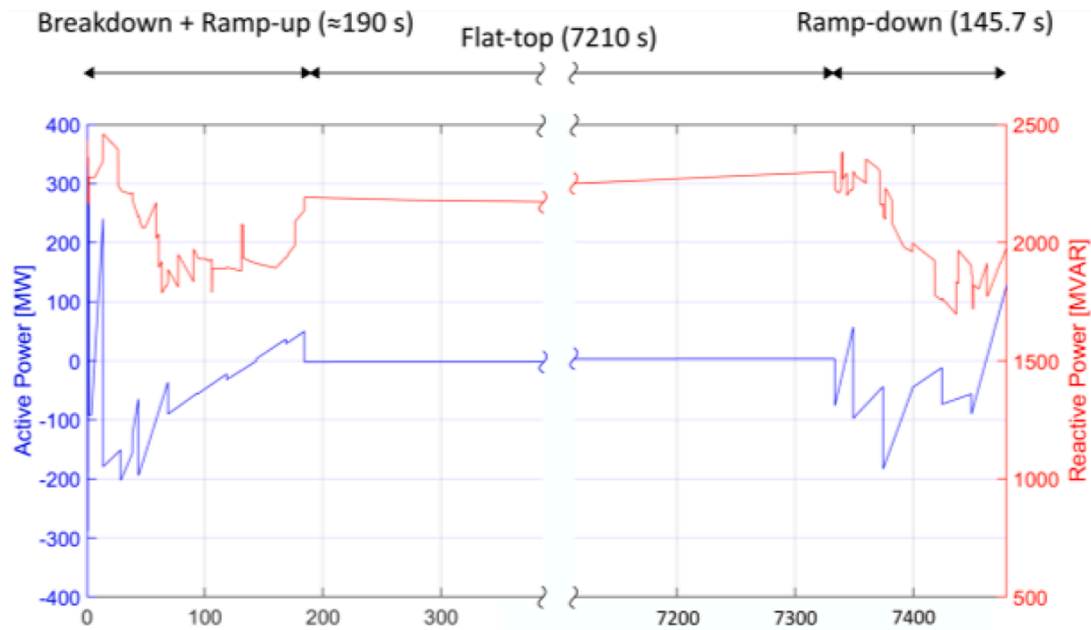

Fig. 7. Active (blue curve) and reactive (red curve) power profiles related to CS and PF BCs assuming sequential control for thyristor converters. (For interpretation of the references to color in this figure legend, the reader is referred to the web version of this article).

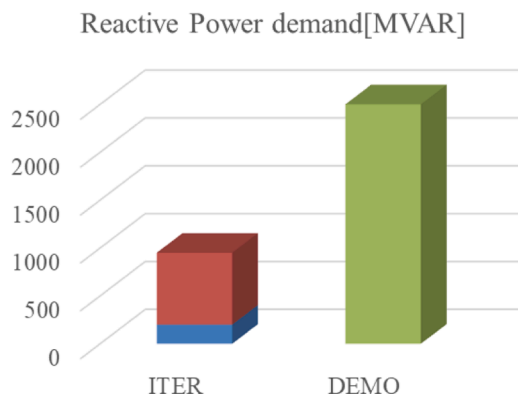

Fig. 8. Estimated reactive power demand by DEMO CS and PF BCs during the breakdown phase compared to that of ITER (blue part: reactive power permitted, red part, to be compensated). (For interpretation of the references to color in this figure legend, the reader is referred to the web version of this article).

The Main Circuit Breaker (MCB) is composed of a Bypass Switch (BPS) in parallel to a Vacuum Circuit Breaker (VCB), with a Counter Pulse Circuit (CPC) necessary to extinguish the arc generated at the dc current interruption [17]. The PyroBreaker (PB) is an explosive actuated switch, acting as a back-up protection in case of failure of the MCB [18].

For the FDU resistors, a modular approach has been followed; a footprint of the DRs was estimated around 640 m², scaling from ITER. The same resistor section has been considered [19] and the resistance variation with the temperature accounted to limit the peak transient voltages. By simulation, it was found a series/parallel arrangement of unified resistor sections (~ 67 m Ω at 20 °C) to significantly reduce the peak voltage, while satisfying the $\int i^2(t)dt$ limit and the maximum resistor temperature (300 °C).

The results are shown in Fig. 12, where the coil terminal to ground voltage is shown for the case with 8 sectors. The peak voltage value, equal to 6.1 kV, is much reduced with respect to that obtained with a constant resistance value (7.68 kV with 103 m Ω), but still exceeds the limit of 5 kV. On the contrary, the coil terminal to terminal voltage,

equal in the 8 sector case to the terminal to ground, is well below the limit of 10 kV.

To improve the voltage transient estimation, a tentative assumption was done on the stray impedance of the cables connecting the switching section to the DR, which length can reach about 250 m in the worst case. The result of the circuit model simulations showed that, without any mitigation, the terminals to ground voltage peaks can largely exceed the design limit, depending on the current derivative on the circuit breakers. This is higher in case of PB intervention, much faster than the MCB, as also noted in studies done for JT-60SA [20]. However, suitable clamping circuits can be effective in smoothing the waveform, without affecting the main coil discharge evolution, as shown on the right side of Fig. 12, where the first fast transient is magnified.

3.2.3. Peak transient voltages in fault conditions

The peak transient voltages in fault conditions were estimated both for the 16 and 8 TF coil sector options. The considered faults were: ground fault at one FDU terminal, failure of one FDU intervention, untimely operation of one FDU, and their combinations. The results of the simulations of the circuit model (for the ITER-like grounding scheme and with 8 TF coil sectors) showed that the worst fault condition (in terms of overvoltages and $\int i^2(t) dt$ increment) consists in the failure of one FDU intervention, plus a ground fault next to the faulty FDU. In this case, the highest peak absolute voltage at one coil terminal versus ground is 22.5 kV, which is within the limit of 29 kV allowed in case of fault condition by the present TF coil design [4]. The maximum increment of $\int i^2(t) dt$ is 8.5 GA²s, which represents 8.4% of the nominal value. Details of the study can be found in [15].

Both for the analyses of FDU intervention and fault case, the uncertainties in the input data are such that any conclusion on the number of coil sectors can not be taken at the present time. The developed models will allow to further assess this issue.

3.3. Issues on the power generation

Differently from ITER, the DEMO, First-Of-A-Kind (FOAK) fusion power plant, shall deliver the power produced by the TG to the HV PTG. Two main BB concept options are to be further explored in the CD phase: the Helium Cooled Pebble Bed (HCPB) and the Water-Cooled Lithium-

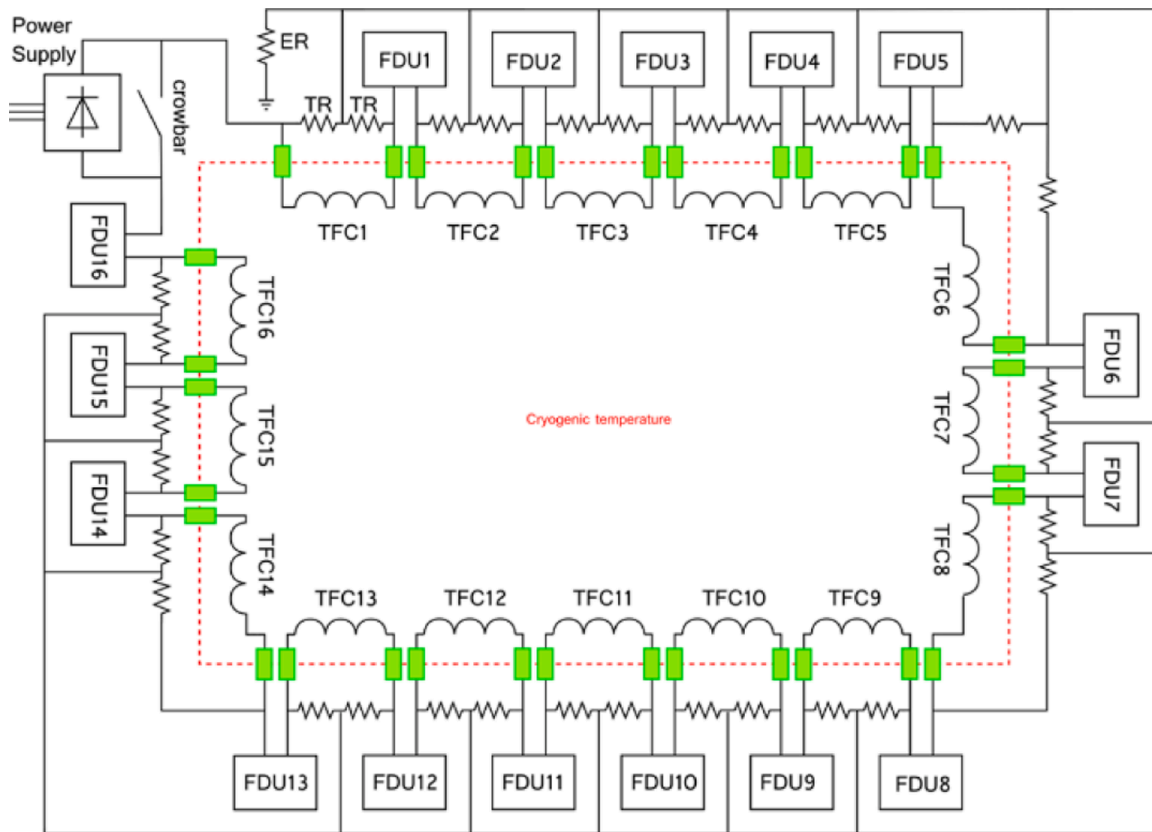

Fig. 9. DEMO Toroidal Field coils with 16 sectors and as many FDU and couples of feeders (in green). (For interpretation of the references to color in this figure legend, the reader is referred to the web version of this article).

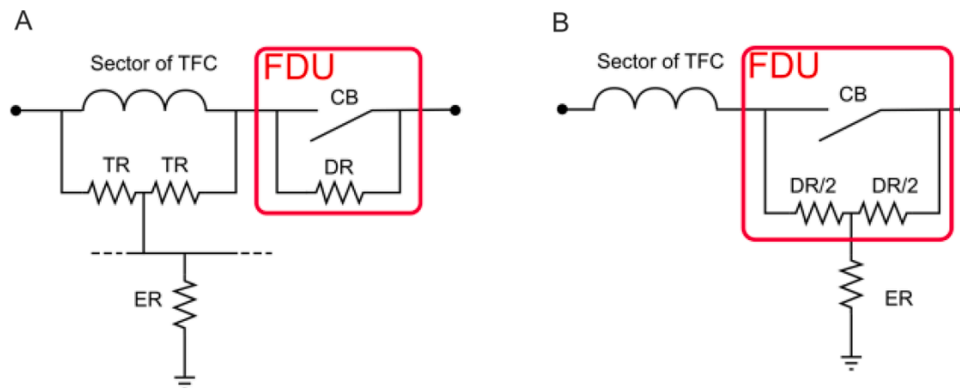

Fig. 10. Principle scheme of FDU inside red box and two possible earthing schemes for the TF FDU: ITER-like (A) and JT-60SA-like (B); ER stands for Earthing Resistor, TR for Terminal Resistor. (For interpretation of the references to color in this figure legend, the reader is referred to the web version of this article).

Table 4

Data assumed for a first ITER-like design of DEMO TF FDU, compared with ITER ones.

	DEMO	ITER
Number of TF coils	16	18
Number of TF sectors	16	9
TF coils current	74.6 kA	68 kA
Inductance of 1 coil	3.61 H	0.985 H
Energy stored in TF coils	161 GJ	41 GJ
Equivalent discharge time constant	35 s*	11 s
Maximum $\int i^2(t)dt$ during fast discharge	103.7 GA ² s	24.5 GA ² s

* In case of constant resistance.

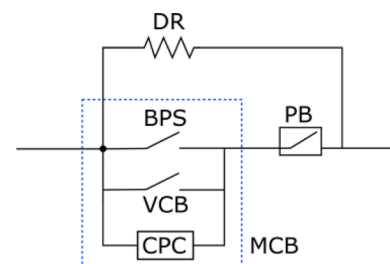

Fig. 11. Simplified scheme of ITER-like FDU.

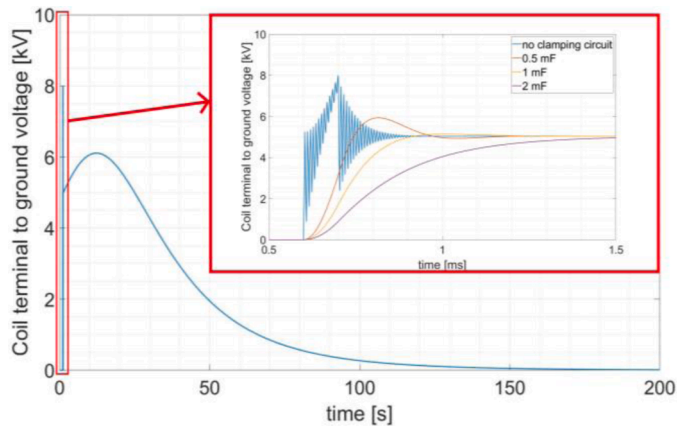

Fig. 12. TF coil terminal to ground voltage at FDU intervention for the case with 8 coil sectors.

Lead (WCLL) [21]. And two coupling options are under study for the BB Primary Heat Transfer System (PHTS) and Power Conversion System (PCS): the Indirect Coupling Option, provided with an Intermediate Heat Transfer System (IHTS) equipped with a thermal Energy Storage (ES) system to buffer energy for PCS operation during pulse dwell time and the WCLL Direct Coupling Option, with the PHTS directly connected to the PCS with some provision to operate at low load the PCS in dwell time [2,3].

The HCPB indirect coupling option and the WCLL direct coupling option with small thermal ES system are the main options selected. A sketch of the gross electrical power generation profiles in the BB PHTS & PCS indirect and direct coupling option is shown in Fig. 13.

The direct coupling option presents issues and limits for the safe operation of the TG to be evaluated, like the capability to safely supply the plant electrical loads without losing the synchronism with the grid. Additional problem for the TG is represented by the large power transients produced by the pulsed load (Fig. 6, Fig. 7) which can perturb its operation.

3.4. Issues and first studies on the DEMO electrical network

DEMO will be both a power source, delivering a pulsed power to the PTG in the BB PHTS & PCS direct coupling option (Fig. 13), and also an utilizer requiring to the PTG the power that cannot be provided by the TG during dwell time and to start/end the plasma pulse. These are unprecedented conditions to be assessed, which represent a big challenge both for the interface with the PTG and the design of the internal electrical network. The first studies on the DEMO PES power system were performed making reference to the ITER power system design criteria and lessons learnt, where applicable Fig. 15.

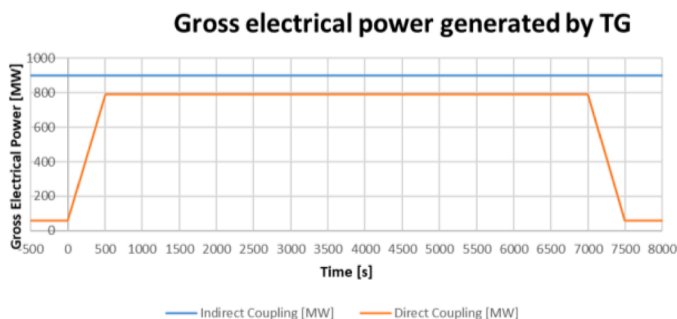

Fig. 13. Gross power generation profiles in the indirect and direct coupling options.

3.4.1. Site assumptions

A suitable site for the European DEMO will be set in the future, so as the details of the interface with the PTG. However, it seems reasonable that the European DEMO can be connected to the PTG at the 400 kV level. Preliminary assumptions on limits to be respected for the interface with the PTG have been made to study the plant power system; they are summarized in Table 5.

These assumptions will be revised during the CD phase, also with the involvement of Transmission System Operators (TSO).

3.4.2. ITER electrical network architecture: main design criteria and lessons learnt

In ITER, two separate networks have been designed, the so-called Steady State Electrical Network (SSEN) and Pulsed Power Electrical Network (PPEN), decoupled by the impedance of the step-down transformers (400/66/22 kV). The reason of this important design choice was due to the large and fast power transients produced by the pulsed electrical loads, which cause on the ac side harmonic distortion and voltage variations. Without decoupling the two networks, the quality of the power distributed to the steady state electrical loads would be much worsened. For the PPEN, the selected values of 66 kV and 22 kV levels were the result of a trade-off between technical and cost considerations among the available high voltage levels, including in the evaluations also the step-down and the converter transformers.

As for the definition of the RPC&HF, composed of 3 units rated for 250 Mvar, connected to as many 66 kV busbars, the main criteria were to limit the voltage variations at 400 kV busbars below 2%, in the range 62–72 kV at 66 kV busbars and the Total Harmonic Distorsion (THD) in compliance with IEC standards.

An additional very important criterion, as a lesson learnt from ITER experience, is to assure the Effective Short-Circuit Ratio (ESCR) above a value that guarantees stability of the distribution system (IEC 60,919). This criterion poses constraints in the relative values of the rated power of the step-down transformers and of the RPC&HF system. In this regard, ITER is a “strong system” being characterized by an ESRC value in between 2.5–5; nevertheless, specific studies were devoted to identify possible instability phenomena due to interactions between the ac/dc converters and reactive power compensation systems and to develop a proper design of related controllers to avoid them [22].

The main criteria for the definition of the SSEN voltage levels were to limit their number and to select values commonly adopted in other applications to limit the cost. Another important criterion was to limit the current of distribution feeders, possibly below 500 A, again to limit their cost. The most common values of 22 kV and 400 V plus the intermediate one at 6.6 kV allowed satisfying the criteria also with a certain degree of flexibility.

The electrical network supplying SIC electrical loads consists of two redundant, independent and segregated trains, to be located in different fire zones, from the power sources (Emergency Diesel Generators (EDG) and batteries), up to the SIC electrical load.

3.4.3. First ITER-like studies of the DEMO electrical network

The same choice of separating the electrical network in two parts serving steady state and pulsed electrical loads would be mandatory for DEMO too, if thyristor converters were selected to supply SC coils, considering the the relevant active power peaks and reactive power demand (Figs. 6, 7). Actually, this separation was assumed for the first

Table 5
Preliminary assumptions for interface with the PTG.

Reactive power	250 Mvar
Active power peak	600 MW
Active power steps	150 MW
Active power derivative	500 MW/s
Fault power level	> 15 GVA

ITER-like studies in the PCD Phase, focused on the electrical network to supply the steady state electrical loads.

The SIC part of the electrical network and EmPS must meet the nuclear safety criteria: redundancy, independence, qualification to normal and accidental environmental conditions and all the other design basis events, in order to avoid common failure modes and to supply in a reliable way the SIC electrical loads that are devoted to bring and maintain DEMO in a safe status (see [7]). It has to be recalled that the SIC electrical system is a vital system for DEMO, and that the safe state cannot be reached and maintained with passive systems.

The electrical supply of SIC and IP electrical loads have to be recovered by the EDGs; on low voltage signal on the emergency busbars, the EDGs starts running, reaching in short time (30 s in ITER, 15 s in NPP) the nominal conditions. Then, they supply the requested electrical loads according to a certain sequence that is completed in few tens of seconds.

The EDG and the SIC part of the electrical network have to be sized to supply, with a certain margin, the SSC in that accident sequence, among those identified as Postulated Initiating Events by Safety (see [7]), requiring the highest electrical power. The design basis accidents are all associated to the LOOSP event [7], some beyond design basis event are associated to the Station Blackout event, the loss of off-site power combined with loss of emergency diesel generators (for 2 h in ITER).

The largest SIC electrical loads in DEMO, as in ITER, are expected to be those of the SIC part of detritiation system, cooling water system and chiller water system.

Fig. 14 shows a section (train A) of a principle single line diagram implementing the general criteria expressed.

3.4.4. Power needs of the DEMO steady state electrical loads

Table 6 summarizes the estimated power installed for steady state electrical loads of the EU-DEMO subsystems, at the present state of their PCD.

For those subsystems with a too preliminary state of the project, the table data are derived by reasonable scaling from other existing or

under-construction tokamaks.

In the table, one should note that for the total power computation for the different phases and coupling options either the values for HCPB or for WCLL have to be considered. The power supplied to the main PHTS in case of HCPB configuration is not constant during the plasma phases, because the compressor motors are operated at 20% of the rated power during the CS Pre-magnetization, the plasma breakdown and the dwell time; after the plasma breakdown the power supplied to the compressors is increased according to a speed time-profile rising at a rate of 20% per minute. Correspondingly, during the Plasma Ramp-down phase the compressors are brought back to the base value.

3.4.5. Estimation of active and reactive power required by steady state electrical loads

A model of the DEMO electrical network to supply steady state electrical loads have been developed to perform Power Flow Analysis (PFAs) that can support in perspective the components sizing.

The data of Table 6 are the inputs; some information, like utilization and coincidence factors are not yet available. The conservative assumption equal to one was made; it will be updated to avoid the over sizing of the electrical components.

The criteria and limits adopted for the components design/sizing are summarized below:

- Limit on maximum voltage drop in the distribution system during operation: 4%;
- Power transformers apparent power higher than required one, even with any possible overload;
- Cables current lower than nominal thermal current limit, chosen among the possible current limits;
- Low voltage level (<1 kV) for electrical loads with a nominal power lower than 200 kW; medium voltage level (> 1 kV) for electrical loads with higher power;
- Splitting of electrical loads among different electrical sub-stations, according to their class

The assumed voltage levels were the ITER-like ones indicated in

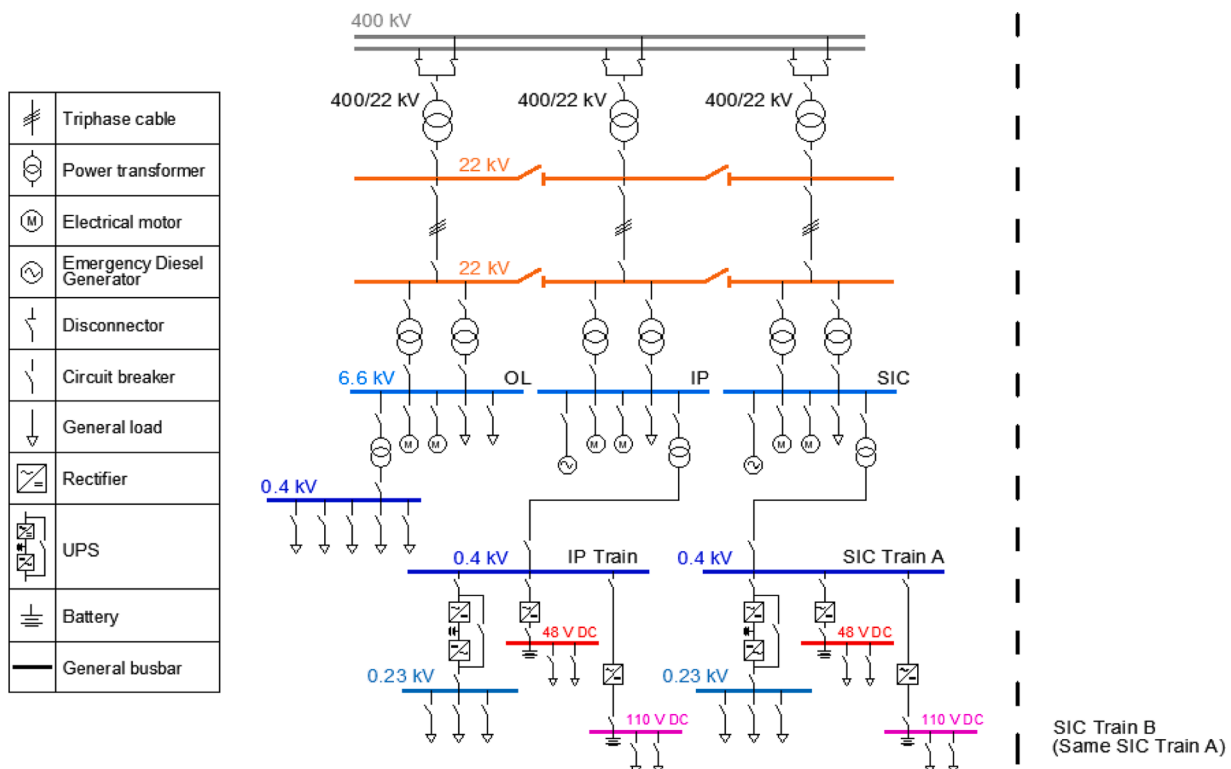

Fig. 14. Principle ITER-like single line diagram of train A; there is a parallel similar train B for redundancy.

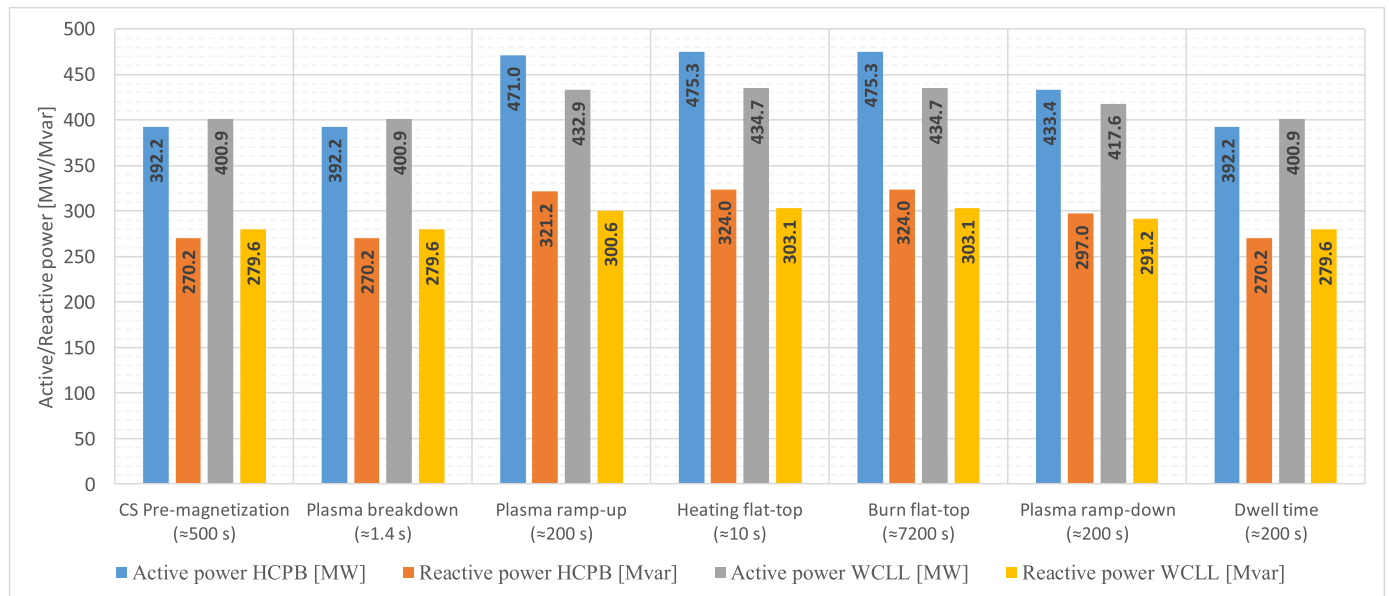

Fig. 15. First estimation of electrical active and reactive power required by the steady state electrical loads.

Table 6

Estimation of power needs for the EU-DEMO subsystems.

DEMO subsystems	Estimated power factor	Indirect Flat-Top [MW]	Indirect Dwell time [MW]	Direct Flat-Top [MW]	Direct Dwell time [MW]
Breeding Blanket PHTS (HCPB)	0,9	100	26	92	18,5
Breeding Blanket PHTS (WCLL)	0,9	30	30	21	21
Tritium, Fuelling, Vacuum	0,8	12	12	12	12
Tritium Extraction and Removal for HCPB	0,8	3	3	3	3
Tritium Extraction and Removal for WCLL	0,8	3	3	3	3
Plasma Diagnostic & Control System	0,9	10	10	10	10
Vacuum Vessel (VV) PHTS	0,9	5.4	5.4	5.4	5.4
VV Pressure Suppression System (HCPB)	1	2.3	2.3	2.3	2.3
VV Pressure Suppression System (WCLL)	0,8	4.6	4.6	4.6	4.6
Divertor & Limiter PHTS (HCPB)	0,8	11	2.2	11	2.2
Divertor & Limiter PHTS (WCLL)	0,8	9	9	9	9
Remote Maintenance System	0,8	5	5	5	5
Assembly	0,9	4.6	4.6	4.6	4.6
Radwaste Treatment and Storage	0,9	3	3	3	3
BoP Power Conversion System (HCPB)	0,90	27	27	68	43
BoP Power Conversion System (WCLL)	0,90	27	27	64	30
Cryoplant & Cryodistribution	0,8	102	102	102	102
Auxiliaries of Power Supply Systems	0,9	39	39	39	39
Buildings	0,9	58	58	58	58
Plant auxiliaries	0,8	91	91	91	91

Fig. 14 and the electrical loads location derived from the present DEMO layout [12].

The model is able to simulate the electrical behavior of the physical components of the system and to calculate the values of the main electrical variables in the simulated system for checking the respect of the limits. It represents a tool for a complete procedure of design and sizing, that should include short-circuit analysis, reliability analysis, etc., to be performed when the status of project of DEMO subsystems will be more mature and detailed. The model for the PFA has been implemented in DiGSILENT PowerFactory [23].

The numerical simulations allowed obtaining a first estimation of the actual active and reactive power needed to operate the power distribution system and its preliminary design; more details of the work done can be found in [24]. Fig. 15 gives a summary of the results for the case of HCPB indirect coupling configuration and WCLL direct coupling configuration [2,3].

3.5. First studies on the TG connection to the PTG

DEMO will be a FOAK fusion power plant, thus it is possible that specific rules will be introduced for the connection to the PTG. However, it is worth to start studying how the generators connected to the European network are used to be designed and operated according to the present EU standards and to discuss the compliance of the TG operation with them.

3.5.1. Issues related to the TG pulsed operation

The European reference standard for the connection of generators to the transmission grid is the ENTSO-E Regulation of 14 April 2016 “Establishing a network code on requirements for grid connection of generators” commonly called RfG network code [25].

Contextualizing the implications of the RfG policy to DEMO generator, they can imply different limitations to the operation of the plant, if the direct or indirect coupling is chosen. Most of the issues are related to the direct coupling configuration [2,3], leading to a pulsed active power delivery to the network. This kind of operation is not in line with the

requirements for Power-Generating Modules (PGMs) of this rating, where the name PGM generically identifies a synchronous generator or a power park. In fact, in reference to [25], a PGM connected to the European grid “shall be capable of maintaining constant output at its target active power value regardless of the changes in frequency”.

On the contrary, the profile of the DEMO output electrical power (Fig. 13), presents so large variations of the output power in short time (hundreds of seconds, i.e. less than 10 min) such that no compensation could be possible, by increasing the delivered power of other power plants, with the risk to compromise the operation of the grid itself, for example if it is in a state of over-frequency or under-frequency and the PGM is unable to activate the frequency response. As a result, if the direct coupling solution will be adopted, some measures will have to be implemented in order to guarantee the proper operation of DEMO generator into the network according to the present ENTSO-E standard.

In case of an indirect coupling configuration, the stable and continuous operation with a fixed active power set-point should be guaranteed thanks to the IHTS. However, the variations in the recirculation power could produce a rate of change of active power not coherent with that required by the system operator, in the limits of the RfG; therefore, also the acceptability of the indirect coupling option will need a careful assessment.

In addition, there could be the requirement for active power control capability if the PGM has to cooperate for the maintenance of the proper frequency on the network in general (frequency stability), and even more if it has to operate in particular network conditions, such as in Limited Frequency Sensitive Mode – Overfrequency (LFSM-O) and Underfrequency (LFSM-U).

The DEMO reactor cannot provide the “black start” capability, which is the capability to start again after a shutdown, without the grid supply.

3.5.2. First studies on connection to the PTG

The connection of new facilities to the national European transmission grid has to be planned in accordance with a proper procedure reported in the standard; as an example, reference can be made to the Italian one [26].

In particular, the evaluation of the voltage level to which the facility has to be connected is performed considering:

- The type and power rating of the facility;
- The characteristics of the neighbouring networks;
- The forecasted locations of the neighbouring power demand and generation facilities for the following 5 years;
- The contribution of the generators to the Short-Circuit Power of the network, which cannot exceed the limits imposed by the TSO at any point.

The definition of the delivery point is subject the following main criteria:

- The power rating of the facility;
- The location of the facility and the presence of generation plants, power lines and HV substations in the influence area;
- The potential implementation of upgrades on the current configuration of the transmission network in the area;
- The static and dynamic stability margins of the transmission network;
- The operation safety of the transmission network where the inclusion is foreseen.

The reference provides a standard solution: in-and-out and radial schemes with a variable number of busbars.

In reference to this standard, some possible configurations for the connection of the DEMO HVN to the PTG have been considered. It is worth to stress that, at the present stage of development of the overall project, there are not sufficient elements which allow getting power profiles with a certain reliability. The profiles shown in Figs. 7 and 13 are intended as indicative of possible scenarios of power to be required or delivered, in order to make qualitative assessments of connection problems.

The main aspects to be taken into account for the definition of possible configurations for the connection are both related to the operation of the facility and to the operation of the external grid.

From the facility point of view in turn, there are two elements to be considered: the proper functioning of the generator and the proper functioning of the plant. In this sense, three configurations have been selected for the evaluation. These solutions involve the choice of the number of Points of Delivery (POD) and the specific substations connected to each point, considering one substation for each main element of the facility, i.e. the TG, the pulsed electrical loads and the steady state electrical loads.

In particular, the solutions considered are sketched in Fig. 16 listed below:

- Single POD, with the TG and all the electrical loads (pulsed or not) connected to the same HV Switchyard;
- Double POD with TG-dedicated node: all the electrical loads (pulsed or not) are connected to one HV Switchyard, while the TG is connected to another HV Switchyard;
- Double POD with pulsed electrical loads dedicated node: the other electrical loads and the TG are connected to one HV Switchyard, while the pulsed electrical loads are connected to another HV Switchyard.

The main characteristics (average and maximum power, maximum power derivative, energy exchanged with the PTG) of the power profiles for each configuration proposed have been estimated in [27]; the effort in the CD phase will be addressed on the one side to smooth the power transient due to pulsed electrical loads and on the other hand to decouple within the DEMO plant the TG, so as the adoption of the single POD connection can be acceptable.

4. Challenges and plans for the PES CD development

4.1. Summary of the main issues identified

The main issues identified during the PCD Phase are summarized below:

- The high active power peaks mainly required for the plasma formation, vertical stabilization and control, due to the high levels of voltages and currents necessary for the SC coils.
- The power utilization factor in particular for coil power supply, which should be increased
- The huge reactive power demand if the classical thyristor converter technology is adopted
- The risk of instabilities in the electrical network connected to need of too large RPC systems
- The reliability of fast discharge units for SC coils

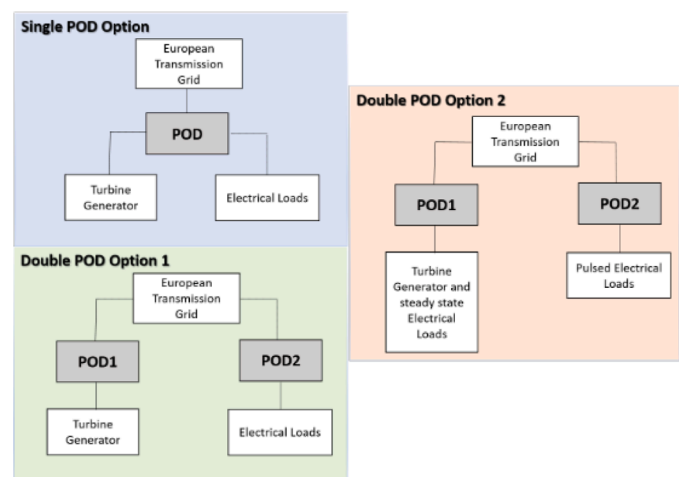

Fig. 16. Sketch of options for the connection to the PTG.

- The generator capability to operate in compliance with the different solutions of the PHTS&PCS

- The need to respect the limits for the interface with the PTG.
- The assurance of required reliability for EmPS

They shall be faced during the CD development taking into account dependencies and interrelations both among PES subsystems and with others DEMO systems. Variants are under study for the most critical DEMO components and the impact on the PES design of choices for some of them, like magnets and power conversion system, is very high.

4.2. Future planning of system design and technological R&D

4.2.1. System level

System level modeling and analyses

All the study toward the PES design definition will be accompanied by development of models of circuits, subsystems and components and by numerical simulations to reproduce their operation, with the aim to estimate and verify the performance.

A comprehensive fault analysis will be carried out, in order to identify the fault conditions which can reasonably occur, to quantify the consequent electrical over-stresses on the electrical loads and the PS components and to identify possible issues on specific technological solutions or further design margins to be taken to mitigate the risks.

A specific line will be devoted to the development of models of the PES plant capable to describe the power flow, to support the evaluation of the amount of concentrated and distributed electrical energy storage within the power supply systems, to achieve an integrated evaluation of the plant operation, to identify possible electro-magnetic instabilities and provisions to avoid them.

Other studies will be aimed to keep updated the estimation of the amount and profile of recirculation power needed to sustain the desired plasma scenarios and verify the limits in the capability to provide it both from the TG and from the PTG.

System level technology R&D

The technology R&D plan mainly aims to find solutions for the several issues identified, but also to explore technologies more attractive, in perspective, with respect to traditional ones, while achieving a good compromise between performance and investment / operation cost.

One of the main target to solve several of the above cited issues is to succeed in maximizing the energy transfer within the DEMO plant, without requiring high power peaks either to the TG or the external PTG. For this purpose, technologies for electrical ES are key ones; Fig. 17 sketches where different electrical ES technologies lie in terms of energy and power density [28–31].

The complexity of the DEMO plant make their application not straightforward. A mix of electrical energy ES systems, based on

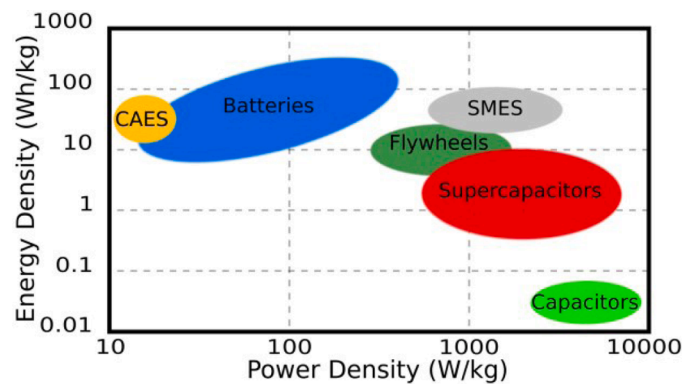

Fig. 17. Comparison among different ES systems in terms of energy and power density, CAES and SMES stands for Compressed Air Energy Storage and Superconducting magnetic Energy System, respectively.

different technologies will be probably necessary for the DEMO PES but most of all they will have to be combined with suitable electrical power converters to provide the required voltage and current waveforms on the electrical loads with the desired dynamics and peculiar requirements. Some of the electrical ES technologies and schemes under investigation for the different PES subsystems are reported in the next paragraphs.

4.2.2. Turbine generator

The work on the TG design will start assuming the technology adopted in the NPPs and verifying its suitability and limits for all the PHTS&PCS configurations.

With direct coupling of the PHTS & PCS in the case of the WCLL BB (Fig. 13), the challenging thermo-hydraulic and mechanical aspects are under study within the Work Package Balance of Plant (WPBOP), while the evaluation of the feasibility of the direct coupling option from the electrical point of view is one of the main objectives of the PES design. In particular, the study of specific issues related to the power delivery to the electrical loads during transients and low-regime operation of the generator are planned.

Another main issue to be assessed is how not to perturb the TG correct operation with the high power transient produced by the pulsed load (Fig. 6, Fig. 7). This will be performed in strict connection with the R&D on the CPS addressed to reduce the power peaks.

All the work on the TG technology will be done with the involvement of the industry.

4.2.3. PES electrical networks (HVN and MLVN)

The studies on the PES electrical networks (HVN and MLVN) are planned to complete firstly the design according to the ITER-like approach and criteria, to verify the limit of applicability and possible additional specific issues when scaled to the DEMO size.

Then, alternatives will be explored with an open minded approach both in terms of definition of voltage levels and architecture of the electrical power distribution inside the plant but considering the lessons learnt from ITER experience.

In particular, if the technology R&D on pulsed power supplies will allow identifying effective solutions in mitigating the highest transient power peaks, it could be possible to overcome the distinction between the electrical networks to serve steady state and pulsed power electrical loads, called SSEN and PPEN in ITER, and to develop an architecture based on a more extended high voltage transmission inside the plant and consequently more optimized in terms of busbars/cable distribution.

Joint work has been planned so as the design of the electrical network will be developed in strict connection with the plant layout design to assure that the two redundant, independent and segregated trains, supplying SIC electrical loads, are always in different fire zones, taking benefit from the experience gained from ITER.

The dependency of the development of the PES electrical networks architecture on CPS and Heating Power Supply systems (HPS) technologies that will be selected is very strong. Again mainly linked with CPS and HPS will be the remaining reactive power to be compensated within the PES electrical network. Suitable RPC&HF systems will be studied to contribute improving the power quality not to perturb the TG operation and to fulfill the requirements for the connection to the PTG.

Involvement of TSOs will be pursued to well understand all the relevant implications, jointly explore suitable solutions, address design choices for key components of the PES power system, analyze fault conditions and relevant protection systems. The development of integrated models is planned to support the studies. Assessment of the pulsed power delivery to the PTG (direct cycle) from the technical and economical point of view will be pursued also with the TSO involvement.

The consolidation of the Electrical Load list for the steady state electrical loads and of the power profiles of pulsed electrical loads represent the essential input for the development of the architecture of both the HVN and MVLN. They will be updated according to the evolution of the EU-DEMO project and of the considered technologies for

the pulsed power supply systems.

4.2.4. Advanced technologies for pulsed power supplies

The MEST. A new Magnetic Energy Storage and Transfer (MEST) system, based on Superconducting Magnetic Energy Storage (SMES), was conceived as an alternative solution to thyristor-based converters to supply the SC coils of DEMO. It is under investigation with the aim to face both the issues related to high active power peaks and huge reactive power demand [32].

The MEST circuit is shown in Fig. 18; the basic idea is to provide an additional SC coil that acts as energy storage reservoir (KC), to be pre-charged before the plasma pulse along with the load coil (LC) and then to transfer the energy step by step from one to the other and vice versa via switched-capacitor (C, S1 – S4), during the different phases of the plasma pulse. The PS has the function to provide the average active power required by the load and to compensate for the circuit losses, which are very low with SC coils.

The MEST can be quite suitable to supply both the CS sectors and the PF coils; in Fig. 19a simplified typical current waveform of a CS sector is sketched to reproduce the operation.

The result of the first studies aimed at estimating the potentiality of this design approach are synthesized in Fig. 20, where the active power peaks requested from the ac side with the design solution based on thyristor converters are compared to the one potentially obtainable with the MEST.

The active power profile required on the ac side is almost flat, since the needed power is not instantly supplied by the network, which provides the average value only. The reactive power demand is not shown, but it is almost nullified, as well.

From the feasibility point of view, it will be necessary to develop a small scale prototype first, as a proof of principle, due to the novelty of the concept and, in case of positive results, it might be appropriate to realize and test another one on a more significant scale for DEMO.

From the operational point of view, the MEST could provide both the FDU (only for LC) and the SNU functions. Future studies will be crucial to understand and evaluate which functions are the most convenient, considering the final requirements in term of current and voltage waveforms, the reliability of the overall CPS system and the fault analysis and protection strategies.

Advanced converter technologies. Other technologies to supply SC coils are under investigation too, such as various topologies of Voltage Source Converter (VSC) with Active Front End (AFE).

VSC based on cascade topology for SC coils supply

The first topology of VSC with AFE considered is shown in Fig. 21; it is based on a cascade connection of bridges (cells in the figure) with fully controllable power switches. With reference to the voltage ratings, two possible VSC with AFE configurations have been considered for the base converters rated for ±8 kV and ±10 kV respectively, with $N = 2$ and $N = 3$ cells in series, respectively. Each cell is composed of a line-side ac/dc

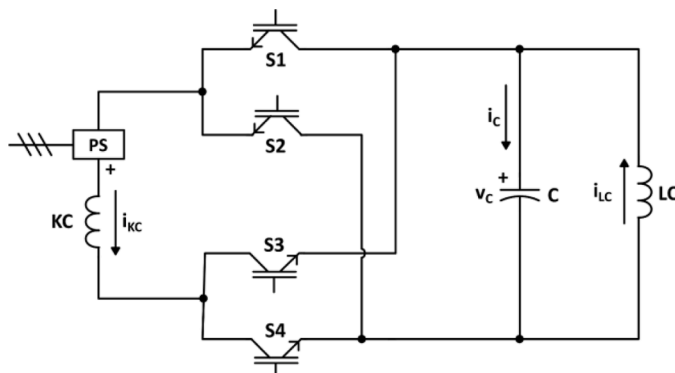

Fig. 18. Principle scheme of the MEST.

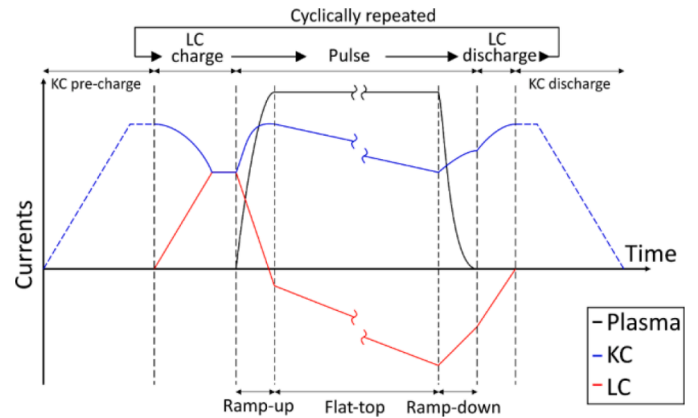

Fig. 19. Typical current waveform of one CS sector.

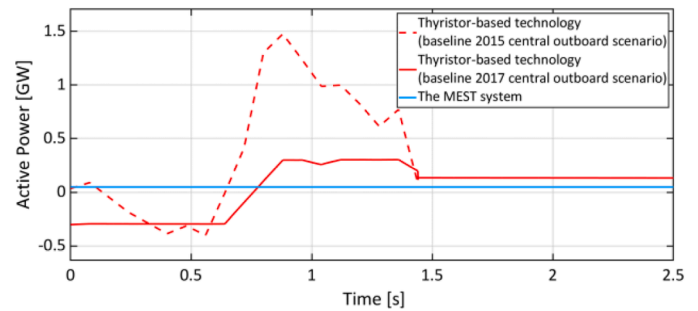

Fig. 20. Expected effectiveness of the MEST in reducing the active power peaks at the plasma breakdown – application study to the DEMO CS and PF coils.

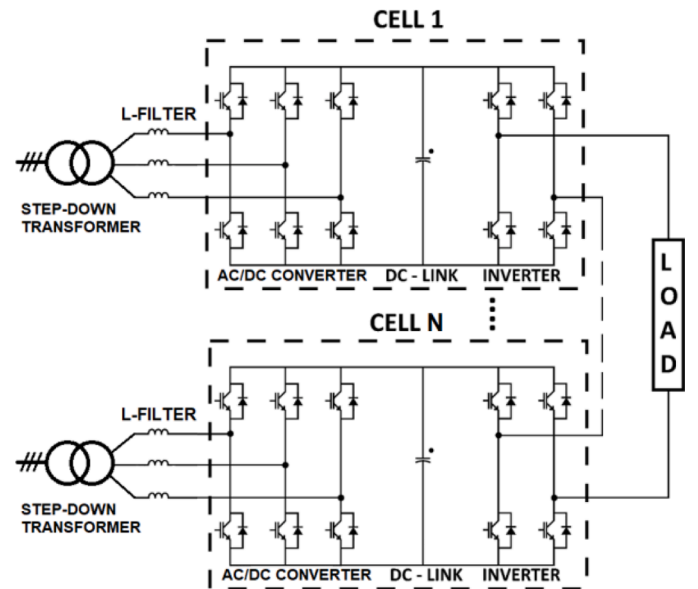

Fig. 21. Possible scheme of a DEMO base converter based on VSC with AFE.

converter, a dc-link capacitor bank and a load-side converter.

The VSC with AFE technology for the DEMO base converters can almost nullify the reactive power demand in every load condition, as demonstrated by numerical simulations [10]. Thus, the consequent large area occupied by the RPC&HF system can be saved.

On the contrary, the capability of VSC with AFE to smooth the active power peaks is strictly related to the advances in the capacitor technology to be used in the dc link section.

Modular Multilevel Converters (MMC) with supercapacitors for SC coils supply

Another R&D line has been started, which derives from the development of a Supercapacitors (Supercaps) based design solution with the MMC topology, which purpose is to study a possible replacement of one of the three Flywheel Generators providing electrical power to the ASDEX Upgrade tokamak experiment. In particular at the Max-Planck-Institute for Plasma Physics in Garching, Germany, a lab scale prototype has been built and it is ready to be tested [33].

The outcomes of this development are relevant for DEMO, in particular in terms of increase of knowledge and expertise on Supercaps. Today, Supercaps can reach a power density of up 5–10 kW/kg, as shown in Fig. 17, similarly to standard capacitors, but with a higher energy density. Furthermore, due to their material composition and design structure, they also have the equivalent series resistance (ESR) lower than Li-ion batteries, which leads to higher efficiency, larger current charge/discharge capacity, and lower losses. However, the limits in terms of voltage rating, ac and high frequency operation and even higher losses than those of standard capacitors, make their suitability for DEMO application not straightforward at the present stage of technology development.

The other aim of this R&D line is to explore the relative merit of MMC topology against others. In MMC converters each branch is made of a large number of modules essentially composed of a DC capacitor and power switches, such to insert or bypass the charged capacitor in the branch. The modules can be connected in series and in parallel and can be individually controlled, thus featuring several advantages:

- Modular structure with identical modules;
- Scalable voltage;
- Redundancy at module level;
- Stored energy distributed among the modules easier to be handled in case of a failure;
- Simple mechanical construction.

On the other hand, the high number of fully controllable semi-conductors and the number of variables to be controlled at the same time lead to a complex control strategy.

Nevertheless, the combination of the high power density of Supercaps and the flexibility/reliability of the MMC topology represent a promising solution to be explored for DEMO pulsed power supply systems.

Discussion on VSC technologies for SC coils supply

To assess the suitability of the VSC with AFE technology as DEMO base converters to supply SC coils, deeper studies are necessary to verify how they can be integrated in the DEMO circuits, considering both normal and anomalous conditions. In particular, the integration of the base converters with the FDU and the overall protection strategies shall be carefully examined.

The capability of VSC with AFE technologies to reduce the reactive power demand is high; on the contrary, the potentiality in terms of mitigating the amplitude of the active power peaks for the DEMO application does not seem as high as that of the MEST. In fact, in the VSC, the ES device is the dc link capacitor and, even assuming further significant step forward of the Supercaps technology in the next years, the gap with respect to the requirement for the application in DEMO seems to remain large.

In addition, it must be pointed out that the feasibility, reliability and cost of VSC with AFE with the ratings required for DEMO is still to be verified, since the highest rated power of an industrial VSC with AFE is presently in the order of few tens of MVA. However, it is important to continue the R&D on these technologies since they are promising in perspective and new applications also in fusion are under development [34], providing return of experience.

Technologies for Fast Discharge Units

The verification of the applicability of the ITER-like technology to TF and PF FDU CB and resistors will proceed in the CD Phase. Alternative technologies will be also explored, and also the feasibility of the

application of the hybrid one developed for JT-60SA CBs [35] will be explored, for PF FDU in particular. For TF FDU, the focus will be more on the evaluation of the impact of dc stray magnetic field and nuclear (neutron/gamma) radiation on the CB presently foreseen to be located in the tokamak; selection of suitable technology and specific qualification procedures shall be performed.

Some analyses on the use of high temperature SC busbars are ongoing [4]; this solution might allow changing the layout moving all the FDU components out from the tokamak building, in another building dedicated to host safety relevant components. The issue relevant to the number of penetrations will be taken into account in such analysis.

VSC for in-vessel coils supply

Analyses have recently started on the possibility to have in-vessel coils in DEMO, for both VS control, and sweeping of the strike points in case of a loss of detachment, also considering the relative merits against ex-vessel coils. In both the cases of ex-vessel or in-vessel coils, VSC technology is the most suitable one, considering the typical dynamic requirements. The studies are at the very beginning stage, but they are planned to proceed in the CD phase with the understandings of requirements and exploration of the most suitable converter topologies.

R&D on high voltage PS for HCD. R&D on technologies that could be potentially interesting for HCD devices has started, in particular for the high voltage PS of Heating Neutral Beam Injectors (HNBI), to be ready for a possible inclusion of the NBI in the HCD mix, during the development of the DEMO CD [6].

The PCD of the DEMO HNBI foresees an acceleration voltage of 1 MV, divided in 5 equal steps (200 kV each). This voltage, which has the same value of ITER HNBIs and MITICA [36] has to be provided by the Acceleration Grid Power Supply (AGPS) [37].

A peculiarity of the AGPS is the required capability to withstand to frequent short-circuits at the output, due to the breakdowns (BD) foreseen among the grids in the accelerator. In such events, the AGPS shall switch off in few tens of μ s, to minimize the energy transferred to the arc and so the damages to the grids. After each BD, the AGPS shall restart in few ms and ramp-up the voltage again. Another important requirement is the capability to provide a voltage regulation range of $\sim 10 \div 100\%$, for the highest flexibility of NBI operation, especially during commissioning.

In ITER and in MITICA, the high voltage is provided by 5 step-up oil transformers, fed at the input by 3-phase Neutral Point Clamped inverters, and connected at the output to diode bridges insulated with SF₆, all connected in series to reach the full voltage up to 1 MV [38].

Alternative technologies are being investigated for DEMO; in particular, the MMC topology is considered [39]. This is based on 3-phase rectifiers, in which each branch is realized with the series of many submodules (SM) and an arm inductor, as shown in Fig. 22. The main existing topologies for the SMs are the Half-Bridge (HB) and the Full-Bridge (FB). While the HB requires half active switches, it cannot interrupt the fault current in case of short-circuit at dc side. Therefore, MMC converters based on FB SM or a mix of FB and HB SM will be also considered.

Specific R&D is required to verify the feasibility of exploiting the MMC topology for the AGPS. The control of such kind of converters is quite complex, since it has to perform many functions at the same time: dc output voltage closed-loop control; ac input current control, unitary power factor and reduced harmonic content; modulation and SM balancing, SM capacitor voltages to follow the desired value and switching losses equally distributed. During the PCD Phase, a very preliminary design of a MMC-based AGPS for DEMO has been attempted, [40] considering only FB SM (Fig. 22).

The static and dynamic performance of the MMC solution have been verified by simulation with a reduced model including a subset of SM and a preliminary control scheme. The results are promising, both in normal, BD and beam-off (loss of load) conditions [40]. The charge transferred to the arc in case of grid BD is reduced with respect to the MITICA-like scheme, thanks to the small output dc filter and the fast

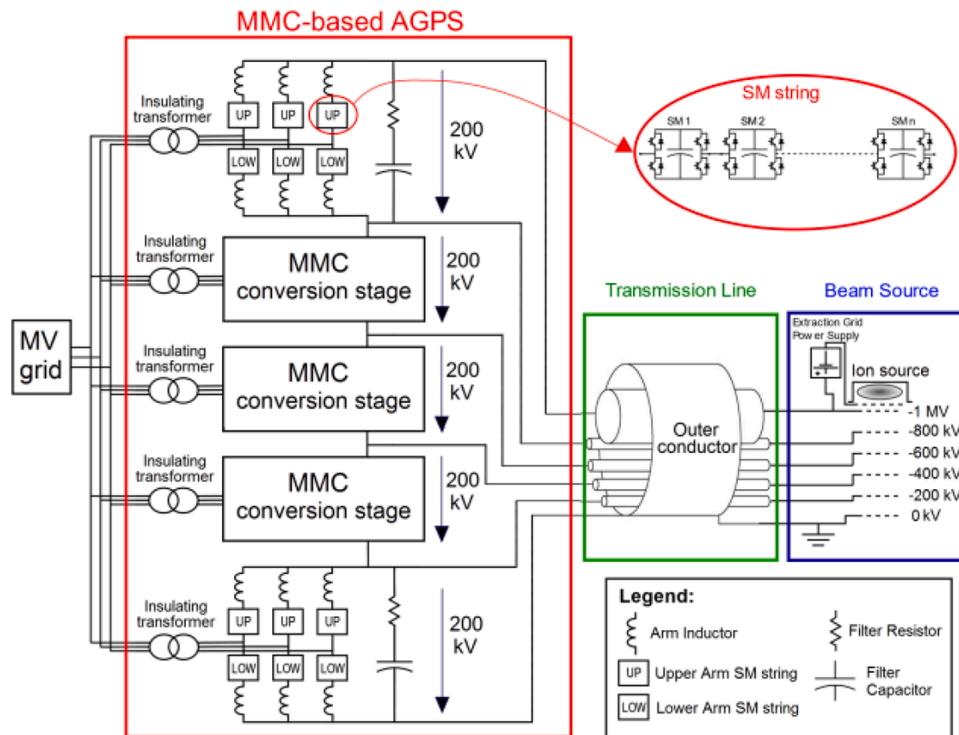

Fig. 22. DEMO NBI AGPS based on MMC, with submodules based on Full-Bridge topology.

switch-off time. A low switching frequency of the single SM is sufficient to guarantee the dynamic requirements, thanks to the high number of SM; this reduces the power losses due to IGBT commutations. Due to the high efficiency, preliminary results show that natural air cooling could be sufficient, avoiding the complication of carrying demineralized water at very high potentials. A high power factor is obtained at ac side, and the modular topology could be exploited to add some redundancies, increasing the availability of the system.

A preliminary estimation of the size of the AGPS based on MMC has been attempted too. Obviously, much more indoor space would be required with respect to the MITICA AGPS, since the conversion system is air-insulated. Future work will investigate the possibility to adopt hybrid FB-HB schemes with optimized control, to reduce the number of components, the overall dimensions and the reliability, without reducing the performance significantly. Comprehensive fault and RAMI analyses will be pursued too, to complement the feasibility study and the comparison with the ITER-like solution.

5. Conclusions

The most important achievement in the PCD Phase was the gain of a broad awareness of the existence of several complex issues related to the PES design, which require extensive studies to be resolved since the beginning of the overall DEMO design.

One of the main issues is the fact that thyristor converters, robust and cost effective technology largely used in all fusion experiments, are not suitable for supplying SC coils when scaled to the DEMO size, due to the too huge reactive power demand and too high amplitude of active power peaks.

The Technical Readiness Level (TRL) of alternatives identified so far for the supply of the DEMO SC coils are quite low. The MEST is fully new, thus a lot of R&D, with the industry involvement, has to be done to prove the feasibility first but also the suitability and convenience of the application to the DEMO case. VSC technologies are already largely utilized in industrial applications, but at power level much lower than those required in DEMO, thus also in this case R&D is necessary, again

with the industry involvement.

Another important issue is related to the power utilization factor (the ratio between the actual active power required by the electrical loads and the installed power) which is very low. This issue is more related to the large difference between the level of voltage needed for plasma formation and instabilities control and that one needed in quiet flat-top phase and is unavoidable to some extent; however room for improvement should be explored.

The level of recirculation power is quite high according to the preliminary evaluations and should be lowered as much as possible.

The generator pulsed operation (direct cycle), so different from that of a NPP, was not addressed so far and needs to be assessed from the technical and economical point of view with the involvement both of the industry and the TSO. The level of power steps and derivatives and voltage perturbations compatible with the stable operation of the grid and of the internal network has to be assessed, too.

Important lessons learnt from the ITER experience will drive the electrical network design, stability verification and layout development. Margins for further architecture optimization will be connected to the success in smoothing the large power transients caused by pulsed electrical loads.

The first milestone of the CD phase is to complete the verification of the applicability or non-applicability of the technologies adopted in ITER or NPP when scaled to DEMO size. This will clarify to which extent it will be possible to benefit from the use of mature technologies and for which components it will be necessary to explore and assess alternative ones toward an integrated viable, reliable and cost effective design for DEMO plant electrical systems.

CRediT authorship contribution statement

E. Gaio: Conceptualization, Methodology, Supervision, Investigation, Writing – original draft, Writing – review & editing. **A. Ferro:** Methodology, Investigation, Formal analysis, Visualization, Writing – original draft. **A. Lampasi:** Methodology, Investigation, Formal analysis, Visualization, Writing – original draft. **A. Maistrello:**

Methodology, Investigation, Formal analysis, Visualization, Writing – original draft. **M. Dan:** Methodology, Investigation, Formal analysis, Visualization, Writing – original draft. **M.C. Falvo:** Methodology, Investigation, Formal analysis, Visualization, Writing – original draft. **F. Gasparini:** Investigation, Formal analysis, Visualization, Writing – original draft. **F. Lunardon:** Methodology, Investigation, Formal analysis, Visualization, Writing – original draft. **A. Magnanimo:** Investigation, Formal analysis, Visualization, Writing – original draft. **M. Manganeli:** Investigation, Formal analysis, Visualization, Writing – original draft. **S. Minucci:** Methodology, Investigation, Formal analysis, Visualization, Writing – original draft. **S. Panella:** Investigation, Formal analysis, Visualization, Writing – original draft. **M. Proietti Cosimi:** Investigation, Formal analysis, Visualization, Writing – original draft. **D. Ratti:** Investigation, Formal analysis, Visualization, Writing – original draft. **L. Barucca:** Project administration. **S. Ciattaglia:** Conceptualization, Project administration, Writing – review & editing. **T. Franke:** Project administration. **G. Federici:** Project administration. **R. Piovani:** Conceptualization, Methodology, Writing – review & editing.

Declaration of Competing Interest

The authors declare that they have no known competing financial interests or personal relationships that could have appeared to influence the work reported in this paper.

Acknowledgments

The authors would like to thank the members of the Design Review panel on the EU DEMO PES for their precious suggestions and recommendations for the future work. This work has been carried out within the framework of the EUROfusion Consortium and has received funding from the Euratom research and training program 2014–2018 and 2019–2020 under grant agreement No 633053. The views and opinions expressed herein do not necessarily reflect those of the European Commission.

References

- [1] G. Federici, et al., The EU DEMO staged design approach in the pre-concept design phase, *Fusion Eng. Des.* (2022) this issue.
- [2] I. Moscato et al., Tokamak cooling systems and power conversion system options, this issue. 2022.
- [3] L. Barucca et al. Maturation of critical technologies for the DEMO balance of plant systems, *fusion engineering and design*, this issue. 2022.
- [4] V. Corato, et al., The DEMO magnet system – status and future challenges, *Fusion Eng. Des.* (2022) this issue.
- [5] M. Siccinio, et al., Development of the plasma scenario for EU-DEMO: status and plans, *Fusion Eng. Des.* (2022) this issue.
- [6] M.Q. Tran, Status and future development of heating and current drive for the EU DEMO, *Fusion Eng. Des.* (2022) this issue.
- [7] M.T. Porfiri, et al., DEMO – the main achievements of the pre – concept phase of the safety and environmental work package and the development of the GSSR, *Fusion Eng. Des.* (2022) this issue.
- [8] E. Gaio, et al., The EU DEMO plant electrical system: issues and perspective, *Fusion Engineering and Design* Volume 156 (July 2020), 111728.
- [9] C. Neumeyer, et al., ITER power supply innovations and advances, in: *Proceedings of the IEEE IEEE 25th Symposium on Fusion Engineering (SOFE)*, San Francisco, CA, 2013, pp. 1–8.
- [10] A. Ferro, et al., The reactive power demand in DEMO: estimations and study of mitigation via a novel design approach for base converters, *Fusion Eng. Des.* 146 (2019) 2687–2691. Part B.
- [11] A. Roshal, et al., Design and analysis of Switching Network Units for the ITER coil power supply system, *Fusion Eng. Des.* 86 (Issues 6–8) (2011) 1450–1453.
- [12] C. Gliss, et al., Integrated design of tokamak building concepts incl. ex-vessel maintenance, *Fusion Eng. Des.* (2022) this issue.
- [13] M. Mattei, R. Ambrosino and R. Albanese, “Annex B to PMI-5.2.1-T016-D001 final report “EM investigations of dynamic phases in DEMO”, December 31th, 2017, Eurofusion IDM link: 2HE47F.
- [14] M. Mattei, R. Ambrosino, R. Albanese, PMI-5.2.1-T030-D001. Final Report “EM Investigations of Dynamic Phases in DEMO”, December 31th, Eurofusion IDM link: 2LFKLN, 2018.
- [15] A. Maistrello, et al., Preliminary studies on DEMO toroidal field circuit topology and overvoltage estimation, *Fusion Eng. Des.* 146 (2019) 539–542.
- [16] I. Song, et al., The fast discharge system of ITER superconducting magnets, in: *Proceedings of the International Conference on Electrical Machines and Systems*, Beijing, 2011, pp. 1–6.
- [17] A. Ivanov, et al., Type tests of counter pulse circuits for the ITER fast discharge units, *Fusion Eng. Des.* 146 (2019) 1934–1937. Part B.
- [18] M. Manzuk, et al., The 70 kA pyrobreaker for ITER magnet back-up protection, *Fusion Eng. Des.* 88 (9–10) (2013) 1537–1540.
- [19] Victor Tanchuk, et al., Air-cooled fast discharge resistors for ITER magnets, *Fusion Eng. Des.* 86 (2011) 1445–1449.
- [20] A. Maistrello, et al., Analyses of the impact of connections’ layout on the coil transient voltage at the Quench Protection Circuit intervention in JT-60SA, *Fusion Eng. Des.* 98 (2022) 1109–1112.
- [21] L. Boccaccini, et al., Results and open challenges in the development of the EU DEMO breeding blanket, *Fusion Eng. Des.* (2022) this issue.
- [22] C. Finotti, et al., Continuous state space model of the ITER pulsed power electrical network for stability analysis, *Fusion Eng. Des.* 139 (2019) 62–73.
- [23] DigSILENT Power System Analysis Software, <https://www.digsilent.de/en/powerfactory.html>. 2022.
- [24] S. Minucci, et al., Electrical loads and power systems for the DEMO nuclear fusion project, *Energies* 13 (2020) 2269.
- [25] Commission Regulation (EU) 2016/631 of 14 April 2016 establishing a network code on requirements for grid connection of generators. 2022.
- [26] Terna, G. Agli schemi di connessione, Annex 2 of “Terna, Accesso alla rete di trasmissione nazionale”.2022.
- [27] S. Ciattaglia, et al., Energy Analysis for the Connection of the Nuclear Reactor DEMO to the European Electrical Grid, *Energies* 13 (9) (2020) 2157.
- [28] H. Ibrahim, A. Ilinca, J. Perron, Energy storage systems—Characteristics and comparisons, *Renewable Sustainable Energy Rev.* Volume 12 (Issue 5) (2008), <https://doi.org/10.1016/j.rser.2007.01.023>.
- [29] A. Rufer, K.O. Papailiou, *Energy Storage*. Springer Handbook of Power Systems, Springer Handbooks. Springer, Singapore, 2022, https://doi.org/10.1007/978-981-32-9938-2_16.
- [30] B. Dunn, H. Kamath, J. Tarascon, Electrical energy storage for the grid: a battery of choices, *Science* 334 (2022), <https://doi.org/10.1126/science.1212741>.
- [31] <https://www.hydrostor.ca/> 2022.
- [32] F. Lunardon, et al., MEST, a new magnetic energy storage and transfer system: application studies to the European DEMO, *Fusion Eng. Des.* (2020).
- [33] A. Magnanimo, M. Teschke, G. Griepentrog, Supercapacitors-based Power Supply for ASDEX Upgrade Toroidal Field Coils, *Fusion Eng. Des.* 171 (2021), 112574.
- [34] A. Lampasi, et al., Poloidal power supply system of the divertor tokamak test (DTT) facility, in: *Proceedings of the IEEE 20th MELECON*, Palermo, Italy, 2020, pp. 634–639.
- [35] E. Gaio, et al., The new technological solution for the JT-60SA quench protection circuits, *Nucl. Fusion* (2018) 58.
- [36] V. Toigo, et al., The PRIMA test facility: SPIDER and MITICA test-beds for ITER neutral beam injectors, *New J. Phys.* 19 (8) (2017), 085004.
- [37] L. Zanotto, et al., Final design of the acceleration grid power supply conversion system of the MITICA neutral beam injector, *Fusion Eng. Des.* 123 (2017) 376–380.
- [38] H. Tobar, et al., Progress on design and manufacturing of DC ultra-high voltage component for ITER NBI, *Fusion Eng. Des.* 123 (2017) 309–312.
- [39] L. Lesnicar, e R. Marquardt, An innovative Modular multilevel converter topology suitable for a wide power range, in: *Proceedings of the IEEE Bologna PowerTech Conference*, Bologna, Italy, 2003.
- [40] D. Ratti, et al., Application studies of the modular multilevel converter topology to the acceleration grid power supply of the DEMO neutral beam injector, *Fusion Eng. Des.* 173 (2021), 112907. December.