

Multiple spatial frequencies Pyramid WaveFront Sensing

*Roberto Ragazzoni (1,2), Daniele Vassallo (1,2,3), Marco Dima (1,2),
Elisa Portaluri (1,2), Maria Bergomi (1,2), Davide Greggio (1,2),
Valentina Viotto (1,2), Marco Guilleuszik (1,2), Federico Biondi (1,2),
Elena Carolo (1,2), Simonetta Chinellato (1,2), Jacopo Farinato (1,2),
Demetrio Magrin (1,2), Luca Marafatto (1,2)*

1: INAF, Astronomical Observatory of Padova – Italy

2: ADONI, Laboratorio Nazionale di Ottica Adattiva - Italy

3: Dipartimento di Fisica ed Astronomia, Università degli Studi di Padova – Italy

Submitted to PASP – January 15th 2017

Revised version – May 18th 2017

Abstract

A modification of the pyramid wavefront sensor is described. In this conceptually new class of devices the perturbations are split at the level of the focal plane depending upon their spatial frequencies and then, measured separately. The aim of this approach is to increase the accuracy in the determination of some range of spatial frequency perturbations, or a certain classes of modes, disentangling them from the noise associated to the Poissonian fluctuations of the light coming from the perturbations outside the range of interest or from the background in the pupil planes, the latter case specifically when the pyramid wavefront sensor is used with a large modulation. While the limits and the effectiveness of this approach should be further investigated, a number of variations on the concept are shown, including a generalization of the spatial filtering in the point-diffraction wavefront sensor. While the simplest application, a generalization to the Pyramid of the well known spatially filtering in wavefront sensing, is shown to promise a significant limiting magnitude advance, applications are further speculated in the area of eXtreme Adaptive Optics and when serving spectroscopic instrumentation where “light in the bucket” rather than Strehl performance is required.

1. Introduction

Wavefront sensor (WFS hereafter) is one of the crucial key elements into attaining Adaptive Optics (hereafter AO) correction together with wavefront correctors; for a review on the subject see Beckers (1993) and Davies & Kasper (2012). One of the elements denoting the quality of the actual AO compensation is the Strehl ratio S , defined as the ratio of the peak of the actual PSF with respect to the nominal diffraction limited one. After a significant period in which $S \approx 0.3$

was considered a reasonable benchmark (see in fact Rigaut & Gendron, 1992 as an example) to characterize a well performing AO, we recently entered (Esposito et al., 2003, 2010) into the realm of the so-called eXtreme AO (or XAO) where $S > 0.9$ is routinely obtained, at least in the bright-end regime in the near infrared, such that dedicated cameras are requested to exploit these performances (Farinato et al., 2014, 2015).

This can be obtained using both WFSs and correctors that are able to attain a large number of modes or conversely a somehow relatively large spatial frequency of the perturbations.

A large number of sensing elements and a large number of actuators become mandatory and, as the system is designed to work in regimes close to the diffraction limit, it has been recognized that the pyramid WFS (Ragazzoni, 1996), both for its efficient use of the detector and for its inherent high sensitivity when used in closed loop (Ragazzoni & Farinato, 1999; Peter et al., 2010) is one of the possible key element in an XAO system (Davies & Kasper 2012). While the ultimate performance of an XAO system can depend upon the kind of WFS used, favoring the pyramid one (Guyon, 2005), this is of course not necessarily mandatory as it has been shown that in the bright-end regime also a conventional Shack-Hartmann WFS is able to achieve extremely good performances (Sauvage et al., 2014). The push for the precision and sensitivity in a WFS however has a twofold meaning: on one hand it would allow to achieve the same XAO performances on somehow fainter stars, while on the other hand, the pupil sampling increase is desirable both for the need to reach higher and higher Strehls (for instance for exoplanets direct detection or scrutiny), or just because observations toward the bluer portion of the spectrum are required (XAO in the visible still remains a target barely reached). In other words, it is true that for a bright enough reference source several kinds of WFS would probably achieve similar performances, but their characteristics in terms of sensitivity allow only the most performing ones to reach the highest Strehl in the visible and to focus also on relatively faint stars, moving away from the bright-end regime. Photons are never enough if one wants to push the boundary of the achievable performance further and further away.

In this context we recently revised the concept of developing some kind of WFS in which the light that does not contribute to the signal to assess the departure of the wavefront from the perfect flat one is not insisting on the detector, so avoiding to perturb negatively the quality of the signal with its inherent Poissonian fluctuations. In their extreme form, these are supposed to work with less and less photons actually detected and have been nicknamed Dark WFSs; see for instance Le Roux & Ragazzoni (2005), Ragazzoni (2015), Arcidiacono et al. (2016), Ragazzoni et al. (2016).

We recently found that such a concept could be applied just to a fraction of the light, properly chosen in a manner that only resembles the hierarchical WFS concept previously introduced (Le Roux et al., 2005) but that, in fact, selects only the light that is responsible for a certain class of perturbations. We show that one can easily design a kind of WFS that splits spatial frequencies in order to turn a pyramid-like WFS into a new device the only senses the photons that are specific to that class of spatial frequencies, with the aim to allow that –under some conditions that has to be properly investigated- reaching a higher SNR in the

given spatial frequencies regime, and specifically the ones that are more responsible to reach the ultimate performance in terms of XAO.

We will also show that this led us to introduce some further classes of WFS, and we tried to identify some further areas of potential interest within the astronomical needs.

2. Splitting spatial frequencies onto the focal plane

Let us consider a typical pupil of a large telescope, characterized by a diameter D and eventually an obstruction denoted by an obstruction linear coefficient ε . Let us now impose on the incoming wavefront a high spatial frequency on one direction defined by a one dimensional sine wave of amplitude W and wavenumber n defined as the number of full waves insisting on the diameter of the pupil (see also Fig.1). This will produce on the focal plane, as the most prominent feature, a couple of additional speckles of diffraction limited, λ/D size, symmetric around the optical axis and located at about $n \times \lambda/D$ from the PSF's center. It is relatively easy to compute the relative brightness of these speckles. Assuming the Marchal approximation, the Strehl can be expressed as

$$S = e^{-\sigma^2} \approx 1 - \sigma^2 \quad (1)$$

where the standard deviation of the perturbation is measured in radians of phase. Using the standard deviation by a sinusoidal wave of amplitude W as:

$$\sigma_W = \frac{W}{\sqrt{2}} \quad (2)$$

one can retrieve that the signal I onto the reimaged pupils, where only the light from the high-frequency speckles is conveyed, is of the order of:

$$I \approx 2\pi^2 \left(\frac{W}{\lambda}\right)^2 \quad (3)$$

For example, when $W=10\text{nm}$ at $\lambda=1\mu\text{m}$, with $S=0.8$ the signal is of the order of 0.2% that is equally split into the two symmetric speckles. This simple consideration is at the basis of the spatial filtering that has been also used in the implementation of the spatially filtered Shack-Hartmann WFS. In that device, see also Poyneer & Machintosh (2004) and Verinaud et al., (2005), a physical stop cancels out at the level of the focal plane spatial frequencies over the pupil above a certain limit, such that these cannot contribute to any aliasing into the sensing of the lower modes.

In a Pyramid WFS, when the modulation is absent or negligible (a choice well tested on the sky, for example, with the MultiConjugated Adaptive Optics Demonstrator, MAD, onboard VLT, see for instance Marchetti et al. 2004) a simplified model of the illumination of the pupil planes that turn out to be useful in the context of this work, is given by assuming that most of the light, when a

perfectly flat wavefront is incoming, is basically confined to the edges of the four pupil images and that the light representing a single spatial frequency perturbation is producing fringe patterns on most of the pupil planes as the result of the interference from the central peak and from each of the pair of the speckles described in Fig.1 depicted as point coherent sources whose light interfere in the pupil plane associated with the two quadrants of the four faceted pyramid where each speckles lie.

2.1 Low pass filtering

Using this model it is easy to estimate the gain in limiting magnitude deriving from the simplest application of the concept described so far, that is a spatially filtered pyramid WFS. Let us assume, in fact, that an AO system will be able to compensate only for perturbation up to a certain spatial frequency. All the highest order modes residual from the atmosphere will hit the outer parts of the pyramid facets and will populate of some light patterns the pupils, although the system has no chance to compensate them. While a detailed calculation of these effects involves using detailed parameters of the AO system under scrutiny, there is a simple calculation that is able to give an estimate of the gain that one is expecting. We note passing by that such a gain must always be positive. In fact the spatial filter has to be chosen not to attenuate the modes that are to be computed and compensated, but will rule out all the lights that has no chance to be used by the second and that will unavoidably introduce some Poissonian noise associated with their illumination of the pupils. If one consider the behavior of a Pyramid WFS in terms of Strehl vs. magnitude the related curve will exhibits a flat behavior in the bright end regime (where the fitting error of the turbulence associated with the limited number of modes sensed dominates) and then a decaying portion toward the faint end, where the Poissonian noise associated with the measurements will dominates (assuming further detectors noise sources are negligible or somehow controlled out). Of course, as long as this second regime is encountered, one can switch the AO system to a more limited number of modes such that an optimum behavior is always attained, although it is likely this will happen in a discretized manner. This is depicted in Fig.2 where a possible layout of a spatially filtered Pyramid WFS is shown as well as an inset.

It is reasonable to assume that the knee occurs when the two sources of errors described so far are comparable. When the Pyramid WFS is spatially filtered the residual uncompensated turbulence will disappears, in contrast with the conventional, non spatially filtered Pyramid WFS. The linearized Marechal expression, as long as it can be used, also indicates that the light in the halo sum up linearly, under this approximation. This means that when the knee of the curves Strehl vs. mag occurs, the residual perturbation of the highest order (the one that leads to the additional illumination of the pupil) will be of the same order of the illumination due to the residual of the correction from the modes actually handled by the AO system.

Under these conditions one can find out at which ratio of brightness the same SNR is achieved, or in other words, the gain in limiting magnitude that can be accomplished with such an approach.

Let us note with I_C the illumination on the pupil under a conventional Pyramid scheme, and with I_{SF} the same parameter when a proper Spatial Filtering is employed. One can easily write:

$$\frac{I_C}{\sqrt{I_C + I_0}} = \frac{I_{SF}}{\sqrt{I_{SF}}} \quad (4)$$

where I_0 is the background illumination due to the uncompensated high order turbulence, that at the knee level, must be of the same order of magnitude of the uncompensated modes handled by the AO system. With this condition one obtains $I_C=2I_{SF}$ translating into a gain in the limiting magnitude of 0.75mags. Using a hand-on simulation through the TRILEGAL model of the Milky Way (Girardi et al., 2012) we estimate an increase in the number of potential reference sources of the order of a factor 1.5, a figure confirmed by a coarse inspection of the published tables at the typical magnitudes of interest here from Bahcall & Soneira 1980. Of course the sky coverage of an NGS-based AO system using such approach has to be adjusted accordingly to a somehow significantly better figure, which in details depends upon a large number of factors not considered here. However, at lowest Strehl ratio, when no longer is holding the approximation described in Eq.1, one should expect a gain somehow smaller, as the variation of the light with respect to the Strehl becomes progressively less steep, although this part of the faint end of the curve is also the less interesting. All this is depicted in the dashed lines in Fig.2 where arbitrary numerical values are given, while the curves behaviour follow strictly the assumptions made in the text.

2.2 High pass filtering

This spatial filtering, selecting the low order modes, the ones actually under control by a sort of conventional AO system, is just the first example of how this technique can be used in a pupil plane WFS context.

If one detects just the spatial frequencies larger than a given amount, these can be conveyed on a pyramid-style splitter and reimaged onto four pupils, where only the information from the spatial frequencies larger than what defined by the spatial filtering are allowed.

The filtered out central portion can still be used for conventional pyramid wavefront sensing of the lowest modes. While this can be of some practical help), the idea behind this concept is that some augmented performances should come out from the fact that the signal from the frequencies larger than the one defined by the equivalent occulting disk are not affected by the plateau of signal coming from the central portion of the PSF from the residuals of the low order modes correction (if any) or, when the Pyramid WFS is used with a large modulation such that the pupils are populated by a certain plateau of illumination even with a flat incoming Wavefront.

We first verified that the measurement principle still works: the signal formed by the proper combination of the pupil planes generated by illuminating the pupils from A', B', C' and D' (see Fig.3) effectively produces a quantity proportional to the first derivatives of the high spatial frequency components of the incoming wavefront and of course the same can be said using the pupils from A, B, C and D, that in fact would simply represent a spatially filtered Pyramid WFS (see also Fig.3).

While the simulation code does not depend upon how practically the light is split and conveyed into several different pupil images, there are several ways to achieve such a goal. It should be taken into consideration that the low and high spatial frequencies would likely require a different degree of sampling (hereafter the terms "low" and "high" would refer to the discrimination introduced by the spatial filtering at focal plane level). If the same format for the detector is adopted, this translates into larger pupils for the high frequency channel, while conveying the same pupil images onto the same detector would require some sort of different zonal binning, whose feasibility will depend upon the detail of the detector involved and it is beyond the limit of this paper. However we sorted out a straightforward design for such a WFS, as depicted in Fig.4 using two different detectors, while in Fig.5a a possible optical layout for this kind of WFS employing the same pupil plane and two possible arrangements for the same detector with different binnings (Fig.5c) or with different kind of detecting devices (Fig.5b), are also shown.

We note, passing by, that a double pyramid as depicted in this and the following examples, do exhibits a non continuous interfaces at their confining edges. A way to overcome this practical issue is to adopt a double pyramid (Tozzi et al. 2008) in which, however, one of the two has a much smaller diameter, defining directly the disk size on the focal plane. This approach, however, would imply a larger distance from the in-focus plane of at least one of the two splitting pyramids.

Even though these WFSs qualitatively deliver the required information, the intensities involved are much fainter than the case for the conventional Pyramid WFS making these solutions, as they have been described, probably of little interest for direct astronomical applications, maybe with the exception of strongly modulated Pyramid WFS, an approach that does not match the ultimate performances that can be reached by such devices, unless some specific application requires an extremely linear behavior under an exceptionally large range. Playing with the simulation code we noted that the plateau in the pupil planes become significantly larger, such that to enter into a regime that this approach would gives some advantage in terms of photon efficiency, only when modulations of at least of the order of $20 \times \lambda/D$.

While the interested reader is also invited to look at the work by Verinaud (2004) this result -when no or little modulation is involved- is not surprising at the light of the model described above as in fact one of the sources of the interference pattern producing the signature of the perturbation on the pupil plane is actually missing: the central peak.

Such a signature (actually the signal coming from the high frequency part of the PSF) can be strongly reinforced if one allows for some of the light in the very central portion of the focal plane region to supply the pupil plane of the high spatial frequency ones.

In practice, a fraction of the central region part of the order of a few percents is enough to reinforce so much the signal in the high spatial frequency pupils at a vanishing small diminution of the signal supposed to supply the low order modes. In Fig.6 several ways to combine portions of the focal planes are described. Further to the different conceptual approach, these are characterized by the fraction η of the light collected in the central portion of the PSF is used to produce the high frequency signal.

Further numerical experiments show that the results are basically independent from the splitting of the inner light into the four facets of the pyramid, and even essentially are powered by the central spike of the PSF (in other words, results are very close to each other using the splitting of the light in the focal plane depicted in Fig.6a, and Fig.6b, and most of the results are obtained just using the approach described by Fig.6c).

This also suggests a couple of further variations, one is just to introduce a sort of pin-hole in the center of the pyramid, the other is to adopt such filtering concept directly to a point-diffraction interferometer (Smartt & Strong, 1972).

There are several ways to incorporate this in manners that can strongly differ in terms of complete use of the collected photons, with the ones involving the (eventually partial) reflection directly on the surface of the pyramid located at the focal plane. A few of these possible examples are listed in a non exhaustive manner in Fig.7, where one should recall that the use of a double pyramid (Tozzi et al. 2008) essentially gives a large degree of freedom on the vertex angle of the first surface, so that a reflective layer deposited properly in that region can be used to convey a selected amount of light η to the proper optical train. Furthermore, a schematic arrangement for the point diffraction modified WFS is shown in Fig.8.

2.3 Toward a spectrograph-friendly WFS

Finally, one should add that within this class of devices maybe there is, in some form, that kind of elusive WFS that, because it senses essentially the high order modes, is able to give, with some degrees of advantage with respect to a conventional WFS where simply the low frequency information is “thrown away”, the right information to the wavefront corrector in order to achieve that PSF engineering largely demanded by spectroscopic applications, where the equivalent sampling is significantly larger than the diffraction limited one but still much smaller than the uncompensated images, ideally forming a top-hat PSF where the energy in the wings is, to a larger degree, conveyed into a central region (Ragazzoni 2015) although with a formally miserable Strehl ratio. The gain of this approach, characterized, using the notation introduced, by $\eta=1$, with respect to a conventional pyramid is somehow easy to estimate. Let us assume that an AO system on a telescope of diameter D is able to handle the WaveFront till a spatial scale defined by d_0 reaching a Strehl S_0 . A Pyramid WFS with a

spatial filter depicted as the one in Fig.9 will be able to make measurements without the disturbance given by the residual light enclosed between the central diffraction limited peak and the size where the PSF is desired to be enclosed, noted by λ/d_1 . Of course the condition $D > d_1 > d_0$ would apply. Using Noll (1976) and assuming the number of modes corrected is proportional to $(D/d)^2$ one can easily workout that, whenever the condition in Eq.1, that is under high Strehl regimes, is fulfilled, the disturbance in the pupil plane from the residual halo in the pupil planes is diminished by the amount:

$$\mu = \left(\frac{D}{d_1}\right)^{\sqrt{3}} \quad (5)$$

Where the ratio in the eq.5 is just the size of the top-hat PSF in terms of the diffraction limit size of the whole telescope, leading, using the same arguments discussed for the low-pass spatially filtered a significant increase in limiting magnitude that could make such an approach very attractive and deserving much further examinations.

3. Perspectives

The number of parameters involved in the classes of devices described so far is rather large. It includes, further to the approach adopted, the amount of the modulation, the fraction of light η eventually conveyed from the central portion to the high frequency pupil planes, the amount of perturbation to be sensed and the amount of the residual low frequency perturbation that one is faced to.

We note that in an XAO system an extremely accurate control of the non common path aberrations can be highly desirable (although a different approach is to establish through a metrological or a rigorous engineering the constrain of such non common path to a minimum) making the case of a large modulation of a certain valuable interest. Also, there is no specific reason to maintain the subdivision of frequencies into just two ranges and one could think, in principle and at expenses of added complexity, to allow more than two of these to be selected, as depicted in an illustrative manner in Fig.10. The edges of the masks that produce the selection of the spatial frequencies is another interesting variable in this game. While one can envisage to use a sort of gradual splitting of the light onto the focal plane, it should be recalled that chromatism inherent to the speckles away from the central peak of the PSF will make, in a real-word white-light WFS, the boundary of the selected frequencies wavelength dependent, and by consequences not as sharp as one finds out in a monochromatic arrangement. Modulation can also play various roles in the frequency splitting depending upon how it is accomplished.

A circular modulation, in fact, would introduce a sort of smearing out of the spatial frequencies selected (as high-order speckles close to the distance from the peak of the PSF dictated by the selecting diaphragms will get in and out from the various channels depending upon their exact location) but a different kind of modulation, like a squared one (characterized by an –although slightly- larger efficiency in the modulation if accomplished around a box rotated by 45 degrees with respect to the pyramid facets) will make a frequency selection that is not

circularly uniform. These observations suggest also the possibility to use selection masks that are not round in order, for instance, to comply with the different ability of the wavefront corrector to compensate different kind of perturbations, because for example number of actuators are not necessarily uniform along different radial directions over the projected pupil.

One could also speculate that the proposed variations can be applied as well to flattened-pyramid (Fauvarque et al. 2015) or axicon-like (Vohnsen et al. 2011) WFSs. It is interesting that some of the properties of a sub-class of the WFSs described so far is likely to be embedded in a generalized Fourier-based descriptions (Fauvarque et al. 2016).

References

- Arcidiacono, C., Ragazzoni, R., Viotto, V., Bergomi, M., Farinato, J., Magrin, D., Dima, M., Gullieuszik, M., Marafatto, L. 2016 SPIE proc. 9909, 99096J
- Bahcall, J.N., Soneira, R.M., 1980 ApJS 44, 73
- Beckers, J.M. 1993 ARA&A 31, 13
- Davies, R., Kasper, M. 2012 ARA&A 50, 305
- Esposito, S., Tozzi, A., Ferruzzi, D., Carbillet, M., Riccardi, A., Fini, L., Verinaud, C., Accardo, M., Brusa, G., Gallieni, D., Biasi, R., Baffa, C., Biliotti, V., Foppiani, I., Puglisi, A., Ragazzoni, R., Ranfagni, P., Stefanini, P., Salinari, P., Seifert, W., Storm, J. 2003 SPIE proc. 4839, 164
- Esposito, S., Riccardi, A., Fini, L., Puglisi, A. T., Pinna, E., Xompero, M., Briguglio, R., Quirós-Pacheco, F., Stefanini, P., Guerra, J. C., Busoni, L., Tozzi, A., Pieralli, F., Agapito, G., Brusa-Zappellini, G., Demers, R., Brynnel, J., Arcidiacono, C., Salinari, P. 2010, SPIE proc. 7736, 773609
- Farinato, J., Pedichini, F., Pinna, E., Baciotti, F., Baffa, C., Baruffolo, A., Bergomi, M., Bruno, P., Cappellaro, E., Carbonaro, L., Carlotti, A., Centrone, M., Close, L., Codona, J., Desidera, S., Dima, M., Esposito, S., Fantinel, D., Farisato, G., Fontana, A., Gaessler, W., Giallongo, E., Gratton, R., Greggio, D., Guerra, J. C., Guyon, O., Hinz, P., Leone, F., Lisi, F., Magrin, D., Marafatto, L., Munari, M., Pagano, I., Puglisi, A., Ragazzoni, R., Salasnich, B., Sani, E., Scuderi, S., Stangalini, M., Testa, V., Verinaud, C., Viotto, V. 2014 SPIE Proc. 9147, 91477J
- Farinato, J., Baffa, C., Baruffolo, A., Bergomi, M., Carbonaro, L., Carlotti, A., Centrone, M., Codona, J., Dima, M., Esposito, S., Fantinel, D., Farisato, G., Gaessler, W., Giallongo, E., Greggio, D., Hinz, P., Lisi, F., Magrin, D., Marafatto, L., Pedichini, F., Pinna, E., Puglisi, A., Ragazzoni, R., Salasnich, B., Stangalini, M., Verinaud, C., Viotto, V. 2015, Int. J. of Astrobiology 14, 365
- Fauvarque, O., Neichel, B., Fusco, T., Sauvage, J.-F. 2015 Opt. Lett. 40, 3528
- Fauvarque, O., Neichel, B., Fusco, T., Sauvage, J.-F., Girault, O. 2016 Optica 3, 12
- Girardi, L., Barbieri, M., Groenewegen, M. A.T., Marigo, P., Bressan, A., Rocha-Pinto, H.-J., Santiago, B. X., Camargo, J.I.B., da Costa, L.N. 2012, ASSP 26, 165
- Guyon, O. 2005 ApJ 629, 592

Le Roux, B., Ragazzoni, R. 2005, MNRAS 359, L23
Le Roux, B., Coyne, J., Ragazzoni, R. 2005 Appl.Opt. 44, 171
Marchetti, E., Brast, R., Delabre, B., Donaldson, R., Fedrigo, E., Frank, C., Hubin, N., Kolb, J., Le Louarn, M., Lizon, J.-L., Oberti, S., Reiss, R., Joana, S., Tordo, S., Ragazzoni, R., Arcidiacono, C., Baruffolo, A., Diolaiti, E., Farinato, J., Vernet-Viard, E., 2004 SPIE proc. 5490, 236
Noll, R.J., 1976 JOSA 66, 207
Peter, D., Feldt, M., Henning, T., Hippler, S. 2010 PASP 122, 63
Poyneer L. A., Machintosh B., 2004, J. Opt. Soc. Am. A, 21, 810
Ragazzoni, R. 1996, J.Mod.Opt. 43, 289
Ragazzoni, R., Farinato, J. 1999, A&A 350, L23
Ragazzoni, R. 2015 Mem. SAIt 86, 450
Ragazzoni, R. 2015 AO4ELT4 conf. proc.
<http://escholarship.org/uc/item/1cp044kv>
Ragazzoni, R., Arcidiacono, C., Farinato, J., Viotto, V., Bergomi, M., Dima, M., Magrin, D., Marafatto, L., Greggio, D., Carolo, E., Vassallo, D. 2016 SPIE proc. 9909, 99096A
Rigaut, F., Gendron, E. 1992 A&A 261, 677
Sauvage, J.-F., Fusco, T., Petit, C., Mouillet, D., Dohlen, K., Costille, A., Beuzit, J.-L., Baruffolo, A., Kasper, M.E., Valles, M.S., Downing, M., Feautrier, P., Mugnier, L., Baudoz, P. 2014 SPIE proc. 9148, 914847
Smartt, R.N., Strong, J. 1972 JOSA 62, 737
Tozzi, A., Stefanini, P., Pinna, E., Esposito, S. 2008 SPIE proc. 7015, 701558
Verinaud, C. 2004, Opt.Comm. 233, 27
Verinaud, C., Le Louarn, M., Korkiakoski, V., Carbillet, M. 2005 MNRAS 375, L26
Vohnsen, B., Castillo, S., Rativa, D. 2011 Opt. Lett. 36, 846

Figures

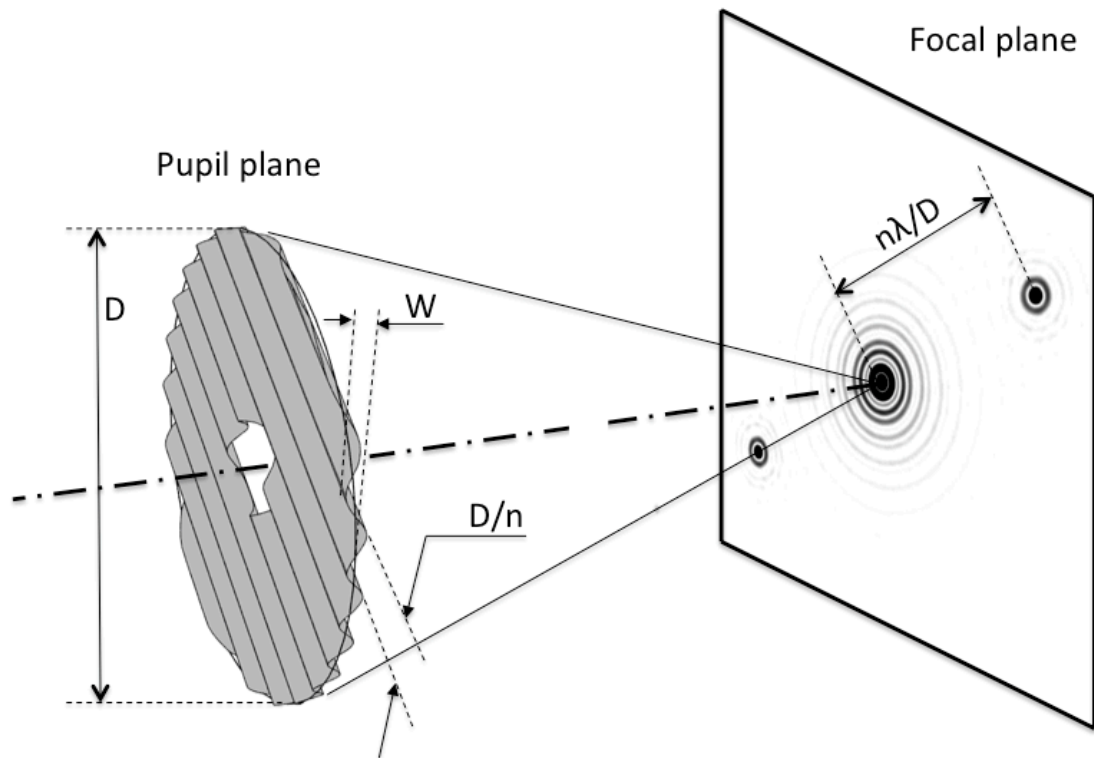

Figure 1: A wavefront with a cylindrical sine wave perturbation with wavenumber n and semi-amplitude W will produce, as prominent feature onto the focal plane of a telescope, a couple of additional speckles located away from the center of the PSF whose location is dictated by the amount of spatial frequency, and whose amplitude is driven by the amount of the perturbation.

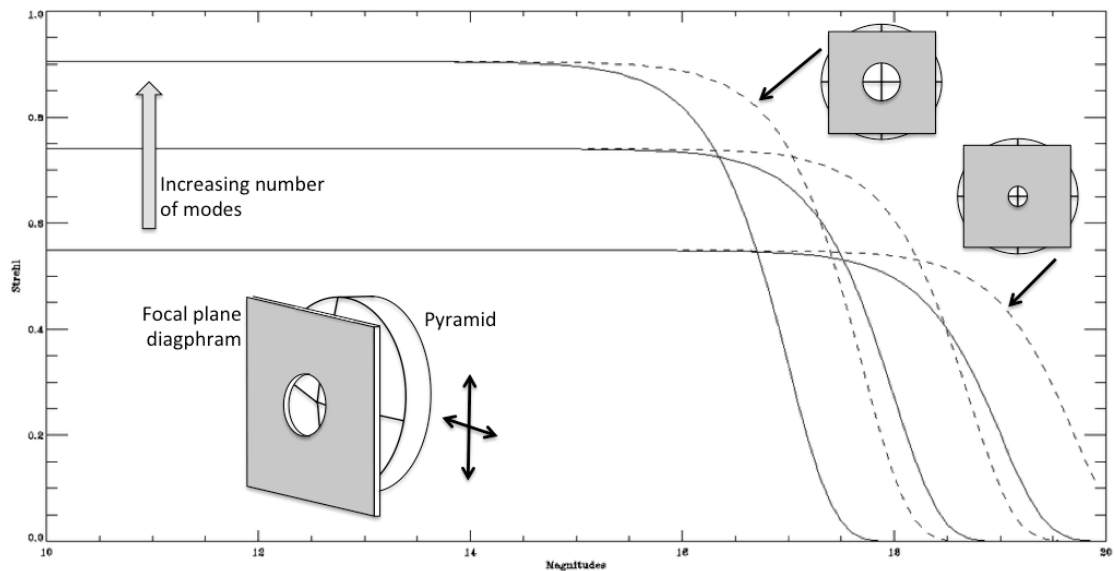

Figure 2: A Strehl vs magnitude curve for a Pyramid WFS with the flat bright end regime and the decaying faint end ones. In the lower left inset a way to build a spatially filtered Pyramid WFS still allowing the pyramidal device to physically modulate the incoming light is shown. The estimated gain in limiting magnitude computed in the text is shown in dashed lines, where two examples of different spatial filtering diaphragm are qualitatively described along two extreme cases of the curves for various number of compensated modes.

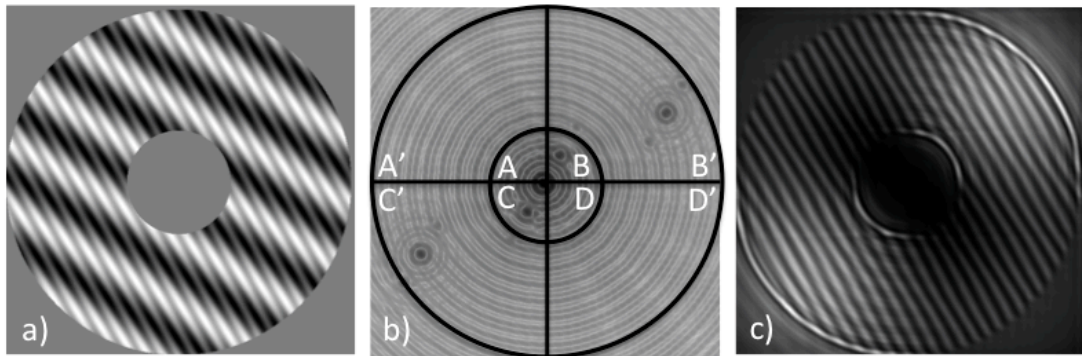

Figure 3: a) The input wavefront perturbation, characterized by a “low” ($n=5$) and a high ($n=26$) frequency sinusoidal cylindrical wave; b) the produced PSF with superimposed the subdivision and naming of the various facets of the multi-pyramid used as WFS; c) an example of one of the several outcome for the image collected at the pupil plane illuminated by the facet B' (in this case $W=20\text{nm}$ and 10% of the light coming from the central pin of the PSF is used to reinforce the fringe signal).

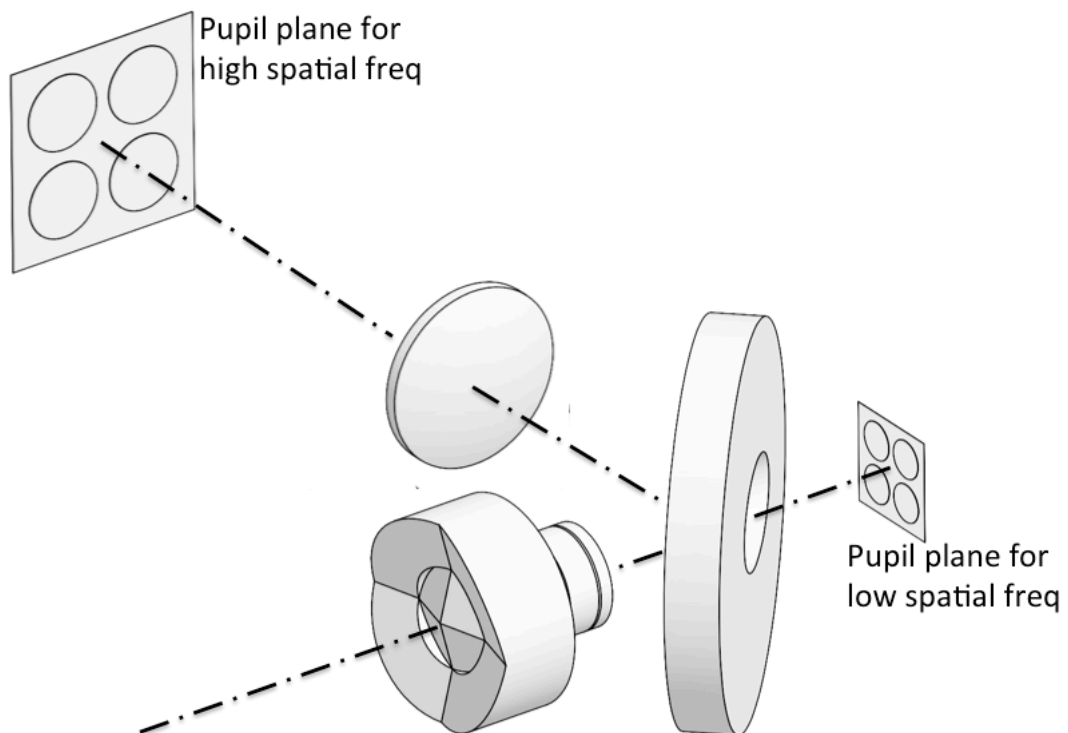

Figure 4: The splitting of the different spatial frequencies is here arranged by a double pyramid whose external part is inverted. The outer ring containing the high spatial frequencies information is focussed by a larger and longer focal length lens such to allow a proper sampling with respect to the central part.

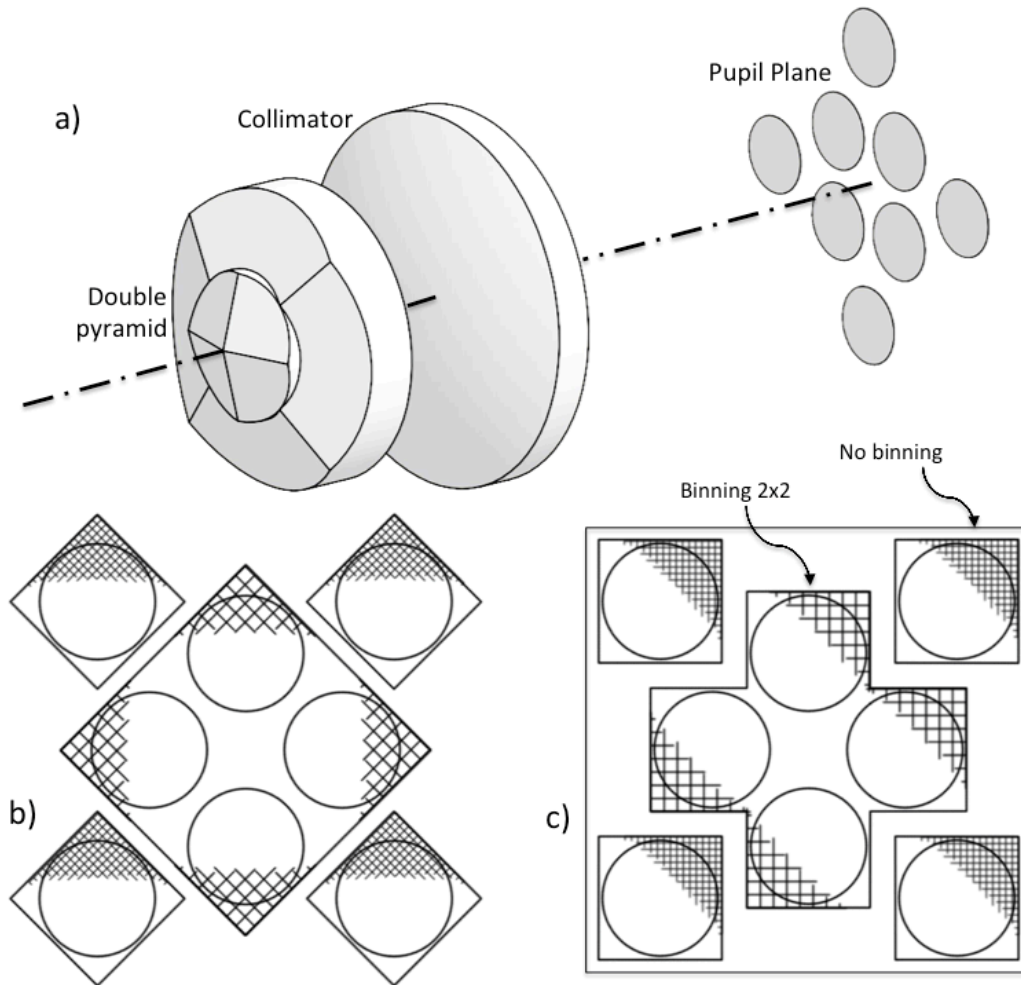

Figure 5: a) A compact possible arrangement that places all the various pupils in the same plane. As the outer part of the double pyramid is retrieving the highest spatial frequency, the sampling over the pupil plane should be adjusted accordingly; b) In this approach five different CCDs with different pixel size are being employed. c) In this example, instead, the same detector is being used, but different binning region are employed in order to convey the proper pupil sampling.

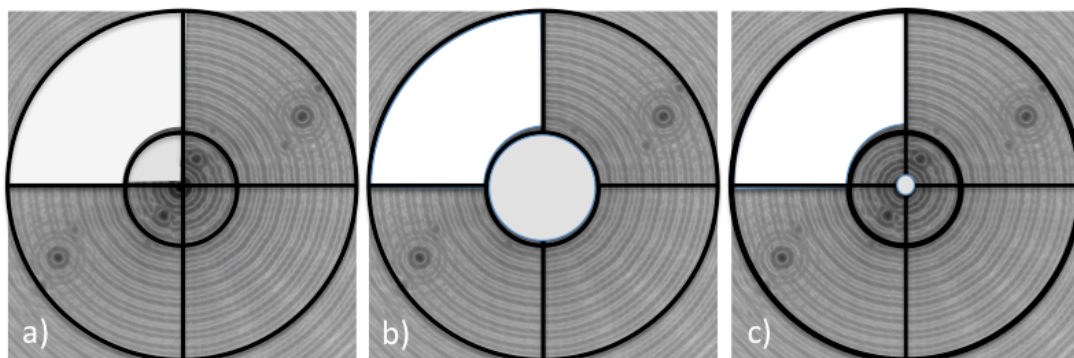

Figure 6: The various options described in the text are here outlined with reference to the top-left quadrant, all the others resulting from symmetrical rotations around the center of the PSF. a) the outer quadrant is combined with the central quadrant multiplied by the factor η ; b) here the central part is not splitted into four quadrants and each pupil will get a fraction of light given by $\eta/4$ of the whole inner portion; c) the same as the previous case but the light is confined to the central diffraction limited spot. Please note that in this case the pyramid splitting will roughly provide the proper redistribution onto the four pupils.

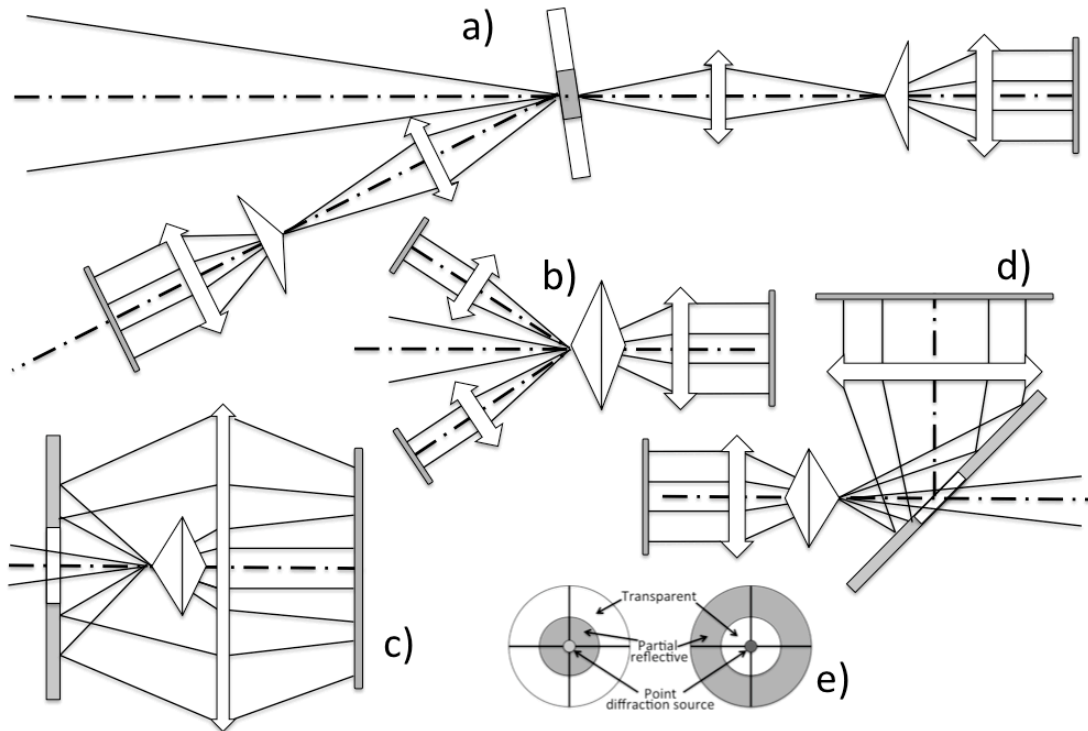

Figure 7: In this composite picture several possible options are briefly outlined with no attempt to run a real ray-tracing detailed simulation. a) light is spatially frequency splitted in an intermediate focal plane and then sent to two pyramid WFS; b) light is reflected on the surface of the pyramid by some fully or partially reflecting layer and each of the four reflected pupils is reimaged by a dedicated optical train while the transmitted light is handled by a conventional pyramid WFS arrangement; c) in this case the reflected light from the pyramid surface is back reflected from a flat or properly curved mirror toward a common large optical system; d) in this approach the back reflected light from the pyramid surface is directed through an annular mirror to a separate optical system handling all the four additional pupils; e) here the various possible arrangements for the various ways the pyramid surfaces in order to comply with the various options described in the text are briefly outlined.

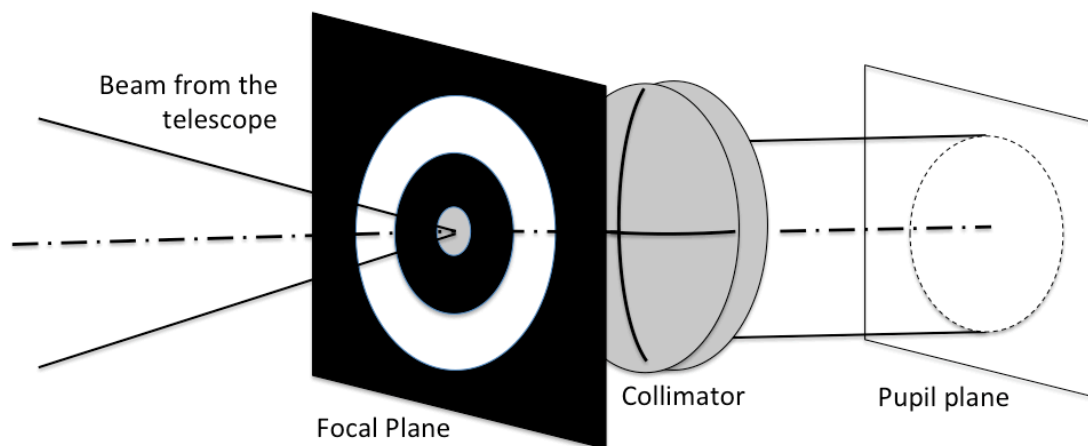

Figure 8: In this variation of the Smartt or diffraction point WFS, the light from the central spot, eventually displaced in phase by a given amount, is interfering with the spatially filtered, high spatial frequency portion, of the wavefront.

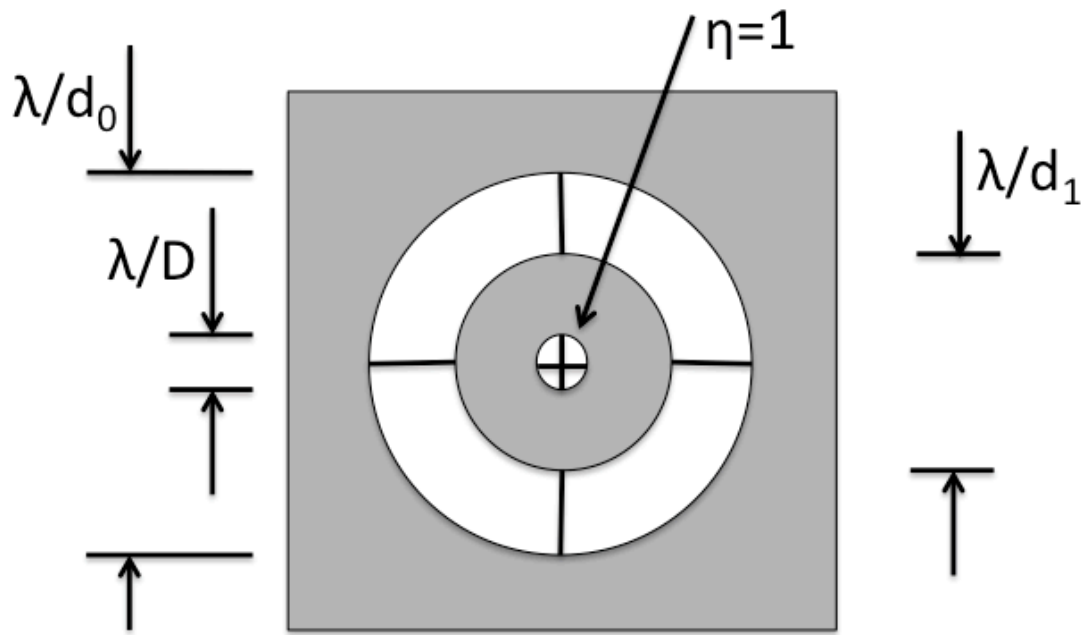

Figure 9: A focal plane spatial filtering depicted in this way will be able to produce a sort of “engineered” PSF whose space is close to a top-hat of size λ/d_1 where the AO system is able to control the WaveFront till a spatial scale of d_0 .

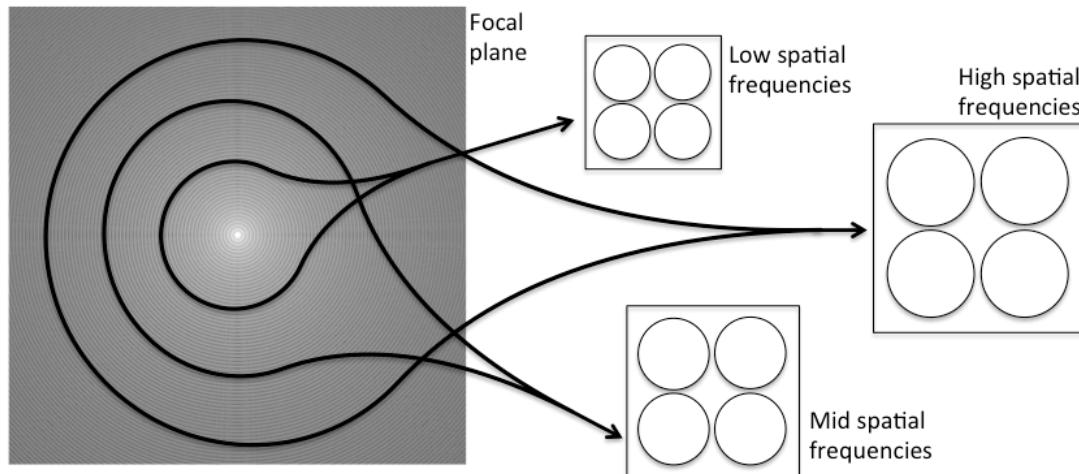

Figure 10: In principle the splitting in the spatial frequency domain can be extended to more than two ranges. Here it is pictorially explained such a concept where at each range of spatial frequency selected on the focal plane a different sampling (assuming a uniform pixel size) of the pupil is envisaged.