

Electric Waterborne Public Transportation in Venice: a Case Study

Mattia Morandin, *Member, IEEE*, Silverio Bolognani, *Member, IEEE*, Pierpaolo Camprostrini, Antonio Ferrari, and Massimo Guarnieri, *Member, IEEE*

Abstract—The paper reports the results of a study for moving the present diesel-based watercraft propulsion technology used for public transportation in Venice city and lagoon to a more efficient and smart electric propulsion technology, in view of its adopted in a near future. Energy generation and storage systems, electrical machines and drives, as well as economic, environmental and social issues are presented and discussed. Some alternative solutions based on hybrid diesel engine and electric and full electric powertrains are compared in terms of weights, costs and payback times. Previous researches on ship propulsion and electric energy storage developed by the University of Padua and preliminary experiences on electric boats carried out in Venice lagoon by the municipal transportation company ACTV and other stakeholders are the starting point for this study. Results can be transferred to other waterborne mobility systems.

Index Terms—Lithium battery, electric boat, electric mobility, electric watercraft, fuel cell, green mobility, hybrid propulsion, hydrogen, marine vehicle, ultracapacitor.

I. INTRODUCTION

IN recent years, the programs for a decarbonized economy and a less-polluted world have fed the development of hybrid/electric road vehicles with different storage architectures. The Toyota Prius, launched in 1997, has been the first mass-produced hybrid electric vehicle (HEV) and is also the top seller in this category, with over 4.8 million units as of September 2014. The siblings Volt/Ampera produced since 2011 by Chevrolet/Opel are the world's best selling plug-in hybrid (PHEV), with global sales exceeding 87,000 units as of November 2014, including their versions rebranded by Vauxhall and Holden. The top seller in the battery electric vehicle (BEV) segment, with 100,000 units as of January 2014, is the Nissan Leaf, launched in 2010. BEV typically range 150 to 200 km, which makes them more suitable for urban mobility. In the luxury segment, the Tesla BEV models

are challenging sports cars as Ferrari and Porsche, while boasting ranges double than other BEVs and exceeding 400 km with Model S. Their sell guidance is 33,000 units in 2014. And new energy sources, namely hydrogen and fuel cells (FCs), are ready for the market. The Hyundai ix35, namely the FC version of the Tucson SUV, put on the market in 2013, is the first mass-produced FC electric vehicle (FECV) and is provided with a 21-kW Li-Poly battery, a 100-kW FC and two 70 MPa hydrogen tanks, assuring a range of 650 km. It will be followed in 2015 by the Toyota Mirai FCV, powered by a 21-kW 1.6-kWh NiMH battery and a 114-kW FC fed by the hydrogen stored in two 122-liter 70-MPa tanks, which allow for a 650-km range. Honda is also ready to sell its FCX Clarity II, with similar performance (Li-Ion battery battery and a 100-kW FC with 35-MPa tanks for a 390-km range). Their success will depend also on the early availability of infrastructural hydrogen refueling stations, which at present cost around \$1M each.

Several municipalities around the world have adopted electrically powered buses for their public transportation. Due to range requirements, a very frequent solution of power supply consists of external sources connected via trolleys, which boasts a glorious story, started by Werner von Siemens in 1882. On-board powered buses preferably resort to HEV propulsion, but BEV are also produced. Starting in December 2010, Seoul has been the first metropolitan area to pass to an all-electric bus service, based on Li-ion batteries which allow a range of 84 km. Fast-charge facilities for buses have been introduced by Proterra (US-CA) in 2012. FC buses have also already appeared, profiting of dedicated refueling stations. London and Hamburg are two large cities which have early included FC buses in their fleets and have programs for expanding them.

For several reasons, the development of electric watercrafts lays far behind road vehicles, mainly because their market is much smaller than car and bus mass productions and because sea-travel ranges remain prohibitive for electric vessels powered only on batteries. However they are worthy of industrial interest, since the technology developed so far for road vehicles can widely be adopted in watercrafts and market opportunities for short-range electric boats already exist. Several small-to-middle size prototypes provided with different energy storage solutions have been built and niche markets, e.g. sensible water environments (mountain lakes, coastal lagoons) [1] and limited-range services (internal and

Paper submitted on April 3, 2015. This work was supported in part by the University of Padova under Strategic Project 2011 MAESTRA.

S. Bolognani, M. Guarnieri, and M. Morandin are with Department of Industrial Engineering, University of Padua, via Gradenigo 6/A, 35131 Padua, Italy (e-mail: silverio.bolognani@unipd.it, massimo.guarnieri@unipd.it, mattia.morandin@unipd.it).

P. Camprostrini is with Consorzio Corila, Palazzo Franchetti, S. Marco 2847, 30124 Venezia, Italy (e-mail: camprostrini@corila.it).

A. Ferrari is with ACTV, Isola Nova del Tronchetto 32, 30135 Venezia VE, Italy (e-mail: antonio.ferrari@actv.it).

city waters, ferries) [2–3], have already been exploited. Generally, they have not yet reached large-scale production to date, possibly with the exception of Duffy Electric Boat Company (US-CA), which, starting in the 70s, has already produced over 10,000 small units in several models [4]. In Europe companies like German Torqeedo, started in 2005, are heading on the same route, proposing advanced solutions for both powertrain and propulsion. At larger sizes, as of 2013 Italian shipbuilder Fincantieri together with American-Italian Fuel Cell producer Nuvera have started a program to develop a high-end marine vessel that will use eight Orion™ fuel cells totaling 260 kW as range extender, i.e. for driving an electric motor for propulsion and/or for recharging the onboard batteries [5]. This solution is already exploited by German shipbuilder HDW in the non-nuclear submarine Type 212A. It uses eleven FC stacks powering a 1.7-MW permanent magnet electric motor (EM), all provided by Siemens, capable of at pushing the vessel at 20 knots in underwater navigation [6]. In cooperation with Norwegian shipyard Fjellstrand and Li-battery producer Corvus Energy, Siemens has also developed a 80-m long ferry powered by two 450-kW EMs fed by a 224-module 1460-kWh Li-ion battery for servicing in a Norwegian fjord, resorting to expensive fast-recharging facilities at each docking. Dubbed MF Ampere, it has been launched on 23 October 2014 and has started servicing in February 2015 [7].

In effect, a wider interest for electric vessels is emerging in several places [8]. In Europe and elsewhere, electric

propulsion is a very attractive solution for navigation in historical water/harbor cities [9] and other environmentally sensible area [10–11], making likely an expansion of the market if proper technology is developed, starting in major historical heritage areas such as the city of Venice and its lagoon. In order to promote the introduction of widespread electric mobility in Venice, the consortium CORILA, the University of Padua, urban transport companies such as ACTV, and other stakeholders have conceived a development plan whose first step consists in designing and constructing one or more prototypes electric vessels for public transportation, depending on available funds. The paper presents the feasibility study of such electric water buses, tailored to Venice's needs and based on up-to-date propulsion and range technologies [12–15]. The envisaged solutions are suitable to be compared with know-how and experiences developed for other sensible water cities (Amsterdam, Hamburg, Stockholm, ...), lagoons, lakes, fjords, and archipelagos (Kornati, Cyclades, Skärgårdshavet, ...).

II. NAVIGATION IN VENICE

A. Metropolitan mobility

Venice has channels instead of streets and squares, and all non-pedestrian urban mobility relies on boats (Fig. 1). Water vehicles include private boats, taxi boats, cargo vessels, waste-



Fig. 1. Venice's space view (courtesy of ESA) and map of its public transportation network. The main winding waterway crossing the city NW to SE is Canal Grande (Grand Canal).



Fig. 2. Canal Grande (Grand Canal), the main waterway in Venice, and its usual water traffic. A vaporetto is in the foreground in the picture below.

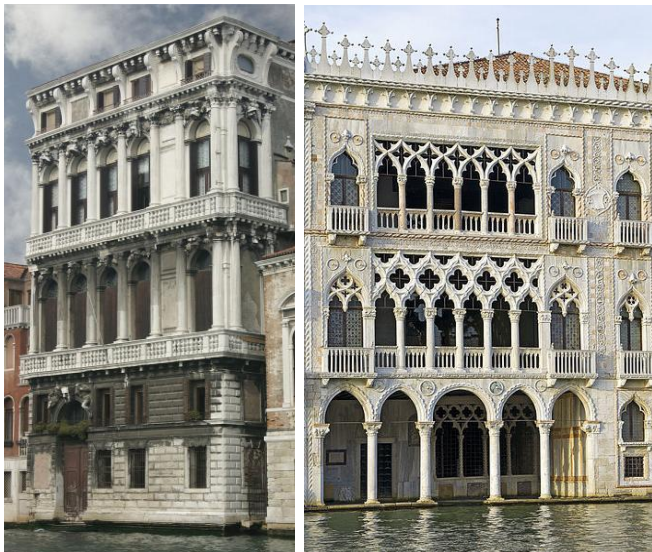

Fig. 3. Pollution effects on Flogini's palace and the restore façade of Ca' d'Oro, both in Canal Grande (Grand Canal), the latter shows the original white-stone aspect of historical buildings.

collection vessels, and water buses. At present, almost all these watercrafts are ICE-powered (internal combustion engine), the larger with conceptually-dated diesel motors (Fig. 2). This mobility system is noisy and at present the major cause of pollution in the fragile environment of Venice's channels, like Canal Grande (Grand Canal) where unique historical palaces face, threatened by the enduring aggression from carbonized fuel pollution (Fig. 3). The municipality is keenly interested in furthering a decisive progress in the city mobility, based on the widespread adoption of electric propulsion, in order to switch to a no-(low)-polluting no-noise mobility, aimed at preserving the unique architectural heritage of the city while offering citizen and visitors a quiet and relaxing ambience.

B. The vaporetto

The fleet for public transportation in Venice is operated by the municipal company ACTV and consists of 160 water buses, which dock in 150 floating piers along the channels and transport over 100 million passengers a year. The major water buses as regards number and global capacity are dubbed "vaporetto" (literally "small steamer", foreground in Fig. 2) after their early propulsion since their appearance in 1881, which have maintained this name when their powertrain changed to diesel about the mid of the past century. A vaporetto has a 24-m long 4.22-m wide hull, displaces 37 tons, within the limits set by municipal regulations), and can accommodate 200 passengers. It has a single rudder propeller powered by a 147-kW marine diesel ICE and services for 16 hours daily. Its present powertrain and its operation are described further on (Subsections IV-A-B).

III. ADVANCED ELECTRIC WATER BUS CONCEPTS

A. Propulsion

The basic electric design consists in the retrofit of an existing vessel maintaining the present single stern-propeller propulsion, while the more thorough designs will assume



Fig. 4. Example of advanced electrical azimuthal thruster with Kort nozzle surrounding the propeller (ducted propeller) and 360° orientation capability developed by French Masson Marine. Five-blade Kappel propeller produced by German Diesel & Turbo.



Fig. 5. Example of vertical-axis Voith Schneider propeller (cycloidal drive) produced by German Voith.

advanced propulsion systems [16]. In particular, a solution based on four azimuth thrusters with electrically driven propellers will be analyzed in detail, which can highly improve the efficiency and speed of docking, while assuring optimal stability and comfort [17]. This solution will involve the redesign of the low bow-wave hull, aimed at avoiding bank erosion. Other propeller designs will be considered as well, e.g. Kort nozzles (ducted propeller) [18], Kappel propeller (with blade tips smoothly curved to the suction side) [19], and Voith Schneider propeller (cycloidal drive, providing almost instantaneous direction change) [20]. In every case, the versatility of the electric drive will provide the speed-torque versatility while avoiding cavitation and vessel vibrations. A Kitchen rudder solution has also been considered, but is deemed less competitive as compared with the previous options coupled to an electric drive. An original anti-cavitation propeller control system will be considered, that will provide improved comfort while avoiding vibrations and reducing fuel consumption. Regarding powertrains, Permanent Magnet (PM) synchronous motor drives will be primarily considered, exploiting the technology developed for terrestrial electric vehicles and already transferred to marine propulsion in some projects carried out by the University of Padua [21–22].

B. Electric energy source

As regards the energy source, the major challenge arise from the long range required for regular service (16 h/day) and from the impracticability of regenerative braking, which affects the straight adoption of established energy management solutions developed for road vehicles. A BEV architecture based on an advanced battery (Li-Ion, NMeH, ...)



Fig. 6. Four tanks occupying a volume of $3.4 \text{ m} \times 2.2 \text{ m} \times 0.52 \text{ m}$ can store 1900 liters of hydrogen at 35 MPa (30.9 kg), sufficient to supply a fuel stack delivering 500 kWh of electrical power (courtesy of Nuvera®).

would require a specific infrastructure consisting of battery-swap or very fast-recharge facilities (e.g. superchargers) due to the long daily service [23], because the energy need of a full daily service would require a too expensive and heavy battery. Such options must be faced together with an electric power supplier like ENEL the major Italian company of the sector, which is installing its road recharging stations, and consequently they are not considered in this study [24].

Instead, two other technologies have been analyzed. The first solution consists of a reduced-size ICE providing the average power to an electric powertrain combined with an electric energy storage system for coping with power demand peaks or ICE power exceeds. This architecture follows a series HEV solution, with the propellers always driven by an electric motor, that allows for an advanced control of the propulsion. The second appealing solution consists of a FC power source fed by hydrogen stored in 4 high-pressure (35 MPa) tanks, within present regulations, with a total volume of 3750 L, which can be easily housed inside the hull (Fig. 6) [25]. A spare tank will allow for the 30% fuel reserve required by municipal regulations. Since the 147 kW peak power is only required for few tens of seconds at docking slow-down and speed-up, in all electric designs the main power source (either ICE or FC) can be sized at a lower level (50-65 kW) with the remaining power supplied by a high-power low-energy energy storage device, such as a ultracapacitor (UC) bank or a lithium battery (LB). This technology can greatly profit of the experience gained in recent years with road FC buses which are in service in several cities. It is worth noticing that Venice's channel water constitutes a natural thermal reservoir for controlling the battery, FC, and motor temperature and will prevent extreme condition (the lagoon water never freezes), thus reducing the thermal control issues. A system of electromagnetic mooring will also be considered, which will replace conventional hawser-based manual operation, in order to allow faster docking.

IV. POWERTRAIN COMPARISON

This case study is aimed at comparing three alternative powertrain options using the standard ICE (S-ICE) powertrain

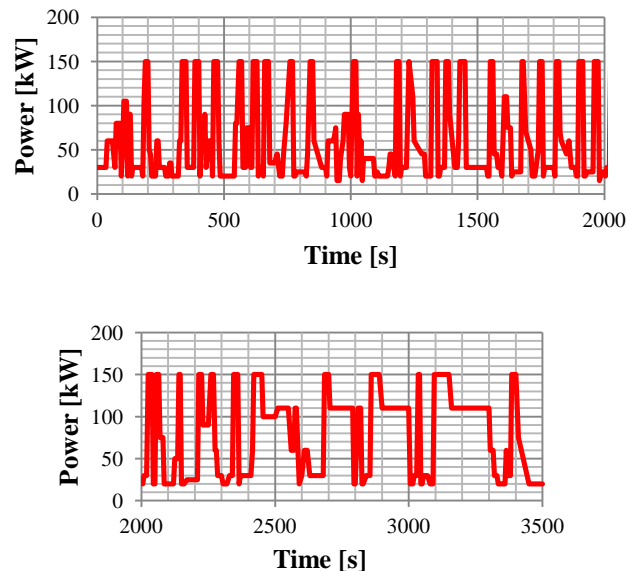

Fig. 7. Power profile during a Line-1 course along Canal Grande.

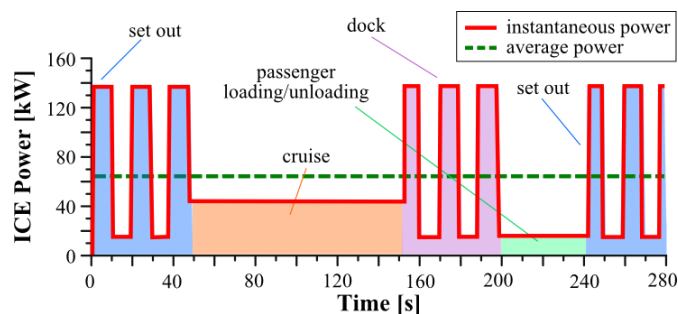

Fig. 8. Simplified power profile during a 240 s = 4 min drive between two stops at piers in Canal Grande

as a benchmark. These electric upgrades are: a) a series hybrid consisting of a reduced-size ICE and a UC energy storage with an electrically driven propeller; b) a series hybrid consisting of a reduced-size ICE and a LB energy storage with an electrically driven propeller; c) a full electric series hybrid consisting of a FC and a UC energy storage with an electrically driven propeller. Since the same outboard powertrain has been assumed in the four cases, the comparison has been carried out among the four inboard powertrains only.

A. Operating cycle

As already stated, a vaporetto services for 16 hours daily. The 147-kW diesel ICE is capable of pushing it at a maximum speed of 20 km/h in suburban waters, but in urban channels ICE's power is reduced to 45 kW so as to limit speed at 7 km/h, whereas idling power at mooring is 18 kW. Docking can occur as often as every 3 minutes with an average of 4 min and is performed with on-off (full-throttle/idle) back-and-forth maneuvers assisted with manual mooring by means of hawsers. The typical power profile during a nearly 1-hour course of Line 1 shuttling in Canal Grande and in suburban water is shown in Fig. 7 [26–28]. The 4-min working cycle performed between dockings can be roughly split into four phases (Fig. 8):

1. set out: about 50 s at 18–147 kW (on/off mode);
2. cruise: about 100 s at 45 kW;
3. pier mooring: about 50 s at 18–147 kW (on/off mode);
4. landing/boarding: about 40 s at 18-kW idling power.

B. Standard ICE – S-ICE

The powertrain of a standard vaporetto is shown in Fig. 9. The 147-kW marine diesel ICE is capable of transferring 117 kW to the propeller shaft at full power (with a transmission efficiency of 80%). The average ICE power along the whole daily service is 60 kW, whereas the average power during cruise (Fig. 8) is about 45 kW and, correspondingly, the average ICE efficiency is clearly lower than the 35% optimal value occurring at full power. Moreover, Figs. 7 and 8 highlight that for more than 70% of time the vessel is maneuvering in on/off mode, i.e. with power at full throttle or idle and possible propeller cavitation. Consequently, noise, vibrations, and pollution are much higher during docking maneuver than in cruise phase. The resulting average operating ICE efficiency is about $\eta_{ICE} = 25\%$, the efficiency of the transmission system is about $\eta_{TRAN} = 80\%$ and a propeller efficiency is about $\eta_{PROP} = 50\%$. Consequently, the maximum overall efficiency from fuel tank to propeller shaft is about $\eta_{PT} = 28\%$ when the ICE works in optimal conditions near rated power, but the average value is about 20% at the shaft and about $\eta_{PT} = 10\%$ only at the propeller.

The ICE consumes 500 liters of fuel in a 16 hours daily service, for delivering 770 kWh of mechanical energy to the propeller shaft. with a running cost about €650/day. The total powertrain capex is about €135,000 of the powertrain, is about €30,000 for ICE, €4,500 for transmission and €35,500 for other components, mainly propeller shaft and propeller.

C. Series hybrid ICE with ultracapacitor – ICE-UC

Fig. 10 shows the Series Hybrid Powertrain that has been considered as a retrofit of a standard vaporetto. It is designed around a 65 kW high-efficiency marine diesel ICE working always at a fixed point/speed and at a maximum power with efficiency $\eta_{ICE} = 35\%$ efficiency. This motor is directly connected to an electric machine rated at the same power and with an average efficiency of $\eta_{EM,1} = 90\%$. This electric machine feeds by a power converter, $\eta_{PC,EM1} = 95\%$, directly connected to another power converter with $\eta_{PC,UC} = 95\%$ that feeds a 60-kW, 10-kWh energy storage ultracapacitor UC, with $\eta_{UC} = 98\%$ round-trip efficiency, sized to face the propeller power fluctuations. The propeller is driven by the original transmission with an average efficiency of about $\eta_{TRAN} = 80\%$, powered by a 120-kW electric machine and a power converter, with efficiencies of $\eta_{EM,2} = 95\%$ and $\eta_{PC,EM2} = 90\%$, respectively (the electric motor has been rated at a power lower than 147 kW, because the electric drive allows a more effective control of the propulsion). The resulting maximum overall efficiency of this series hybrid powertrain is around $\eta_{PT} = 20\%$ and the average efficiency during a working cycle is about $\eta_{PT} = 19\%$, because the ICE always works at the optimal point. Consequently, the

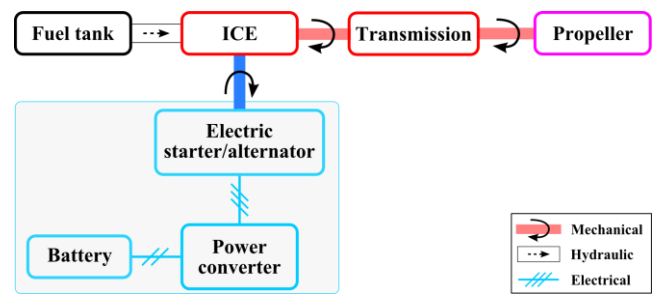

Figure 9: Scheme of the standard ICE powertrain – S-ICE

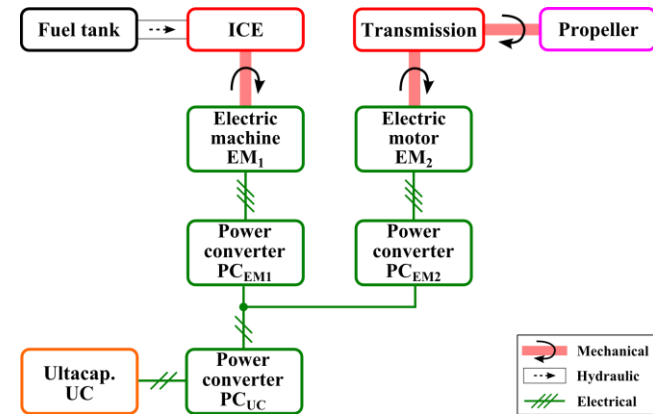

Fig.10. Scheme of ICE – UC series hybrid powertrain

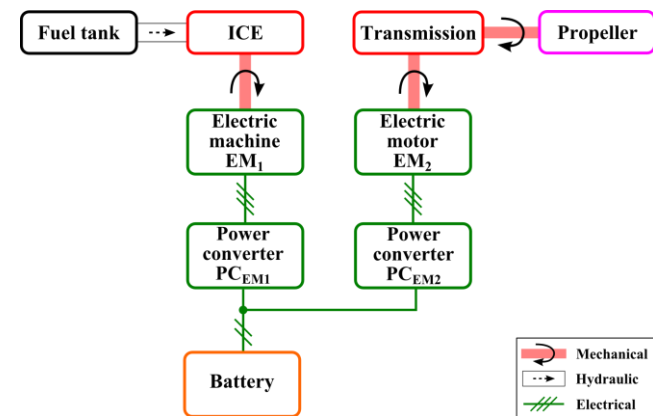

Fig. 11. Scheme of ICE-LB series hybrid powertrain.

estimated daily consumption is 250 L of diesel fuel with a running cost around €320/day. On the other hand, the powertrain capex becomes €260,000.

D. Series hybrid ICE with Li battery – ICE-LB

The Series Hybrid powertrain with Li-poly battery is shown in Fig. 11 and is quite similar that shown in Fig. 10. It is designed around a 50-kW high-efficiency marine diesel ICE working always at a fixed point/speed and at a maximum power with $\eta_{ICE} = 35\%$ efficiency. This motor is directly connected to an electric machine rated at the same power and with an average efficiency of $\eta_{EM,1} = 90\%$. This electric machine feeds by a power converter, $\eta_{PC,EM1} = 95\%$, directly connected to a 70-kW, 300-kWh Li-poly battery with

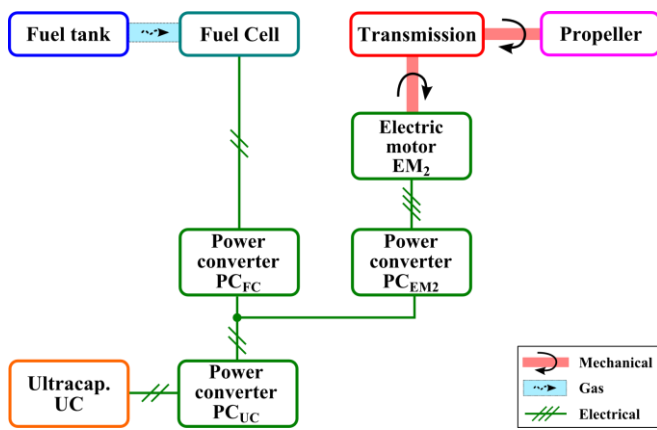

Fig. 12. Scheme of FC-UC series hybrid powertrain.

$\eta_{\text{bat}} = 93\%$ round-trip efficiency, sized to face the propeller power fluctuations. The propeller is driven by the original transmission powered by a 120-kW electric machine and a power converter with efficiencies of about $\eta_{\text{EM}_2} = 95\%$ and $\eta_{\text{PC}_{\text{EM}_2}} = 90\%$, respectively. Considering again the original transmission with efficiency of $\eta_{\text{TRAN}} = 80\%$, the maximum overall efficiency of this this hybrid powertrain results $\eta_{\text{PT}} = 23\%$. Consequently, the estimated daily consumption is 180 L of diesel fuel with a running cost around €230/day and an additional cost for recharging the battery around €50/day. In this case the powertrain capex becomes €334,500. The main issue of this power train is the weight of the battery packs (22,500 kg).

E. Series hybrid Fuel Cell and ultracapacitor – FC-UC

The fuel-cell based powertrain is shown in Fig. 12. It consists of a 65-kW high-efficiency PEM fuel cell with $\eta_{\text{FC}} = 50\%$ that feeds a power converter, with efficiency of $\eta_{\text{PC}_{\text{FC}}} = 88\%$, directly connected to the DC bus. Power fluctuations are provided to the DC bus by a 60-kW and 10-kWh ultracapacitor (as in the ICE-UC), fed by a DC/DC power converter, with efficiencies of $\eta_{\text{UC}} = 98\%$ and $\eta_{\text{PC}_{\text{UC}}} = 95\%$, respectively. The propeller is connected to the original transmission with an average efficiency about $\eta_{\text{TRAN}} = 80\%$, powered by a 120-kW electrical machine and a power converter, with efficiencies of $\eta_{\text{EM}_2} = 95\%$ and $\eta_{\text{PC}_{\text{EM}_2}} = 90\%$, respectively. The overall efficiency of this hybrid fuel-cell powertrain is $\eta_{\text{PT}} = 35\%$ from the hydrogen tank to the propeller shaft and the estimated daily consumption of hydrogen is about 30 kg, with a consequent operating cost of €150–200/day, assuming hydrogen produced by means of a methane reformer. In this case the estimated powertrain capex is €361,000.

F. Powertrain comparison

Fig. 13 shows the energy profile provided by the power sources considered in the powertrains during a 1-hour course of Line-1. Two different types of electric powertrain are compared, ICE-UC and ICE-LB, differing in the energy storage device (green dot-dash line), namely the ultracapacitor

(UC) in Fig. 13a and Li-poly battery (LB) in Fig. 13b. In both cases, the energy profile of the electric machine (red dotted line) is compared with the energy profile of the S-ICE (blue solid line). Fig. 13a shows that in the case of ICE-UC, due to the chosen sizing, for about 2,800 s (47 min) the rated power of the 65-kW ICE is higher than what needed at the propeller and the excess power charges the UC. Instead, in the suburban stretch the UC is discharged in order to cope with the higher power demand. Fig. 13b shows that in the case of ICE-LB, during the whole course the batteries are always discharged, since a smaller 50-kW ICE has been considered. Fig. 13a basically holds also in the FC-UC case, because the FC ratings is the same as for ICE of the ICE-UC are the same (65 kW), while the efficiencies from ICE to shaft for ICE-UC and from DC bus to shaft for FC-UC are similar, i.e. 0.86 and 0.88, respectively. Fig. 14 shows that in both ICE-UC and ICE-LB cases the fuel consumption is lower as compared to a conventional ICE powertrain, because in both ICE-hybrid cases ICEs work at a fixed optimal working point so that the fuel consumption is about a half compared to the S-ICE powertrain. Fuel consumption is lower in the ICE-LB (Fig. 14b) than in ICE-UC (Fig. 14a), mainly because the rated power of the ICE is lower in ICE-LB. In the case of FC-UC, fuel consumption is about 2 kg of Hydrogen per course, i.e. about 30 kg per day. Consequently, the consumption is about 5-8 time lower in weight than with hybrid ICE powertrains, but the price of fuel (€/kg) is about 3–4 time higher. Nevertheless, it must be considered that emission is zero in the case of the FC powertrain.

The main results of the comparison are summarized in Table I. Since the same standard propeller transmission and the propeller have been considered for all powertrains, they have not been accounted for in the table. Tabulated data regard weights, capexes, running costs and payback times. It is worth noticing the increase of weight of the vessel when using electrical propulsion. However this negative aspect is dramatic only in the case of ICE-LB while it is acceptable in the other cases and can be compensated by lower weights of other boat components if a whole redesign is considered. A special attention can be paid to the economic aspects. All the electric propulsion strategies involve an increase of the vessel cost. However the higher cost is accompanied by a reduction in cost per day for energy consumption resulting in a payback time of about 3 years. It has to be pointed out that costs of infrastructures have not taken into account here. In effect, the issues of analyzing the recharging/refueling infrastructures are out of the scope of this study and their solution has to be faced in the framework of an agreement among transport companies, municipality and industrial partners, such as ENEL, for fast electric chargers, and Hydrogen Park (a local company whose mission is exploiting industrial byproduct hydrogen), for hydrogen refueling. On the other hand, it is worth noticing that pollution-related costs, which can be very high in the case of a historical city like Venice, can change the results, giving a major support to the electric options.

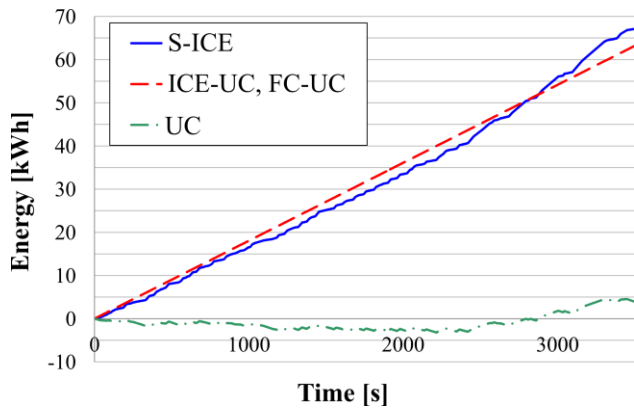

(a) ICE-UC Series Hybrid and FC-UC

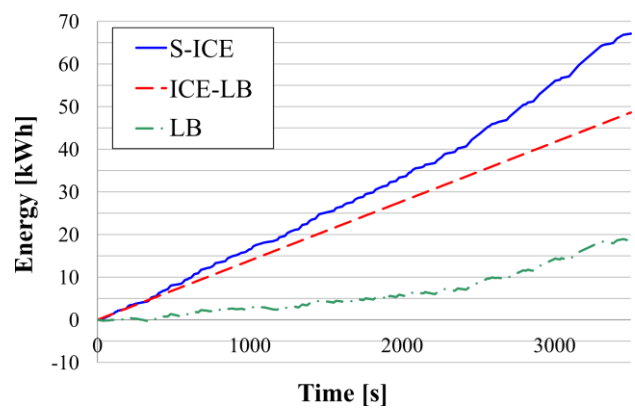

(b) ICE-LB Series Hybrid

Fig. 13. Energy supplied by primary sources and stored energy during a 1-hour course of Line 1

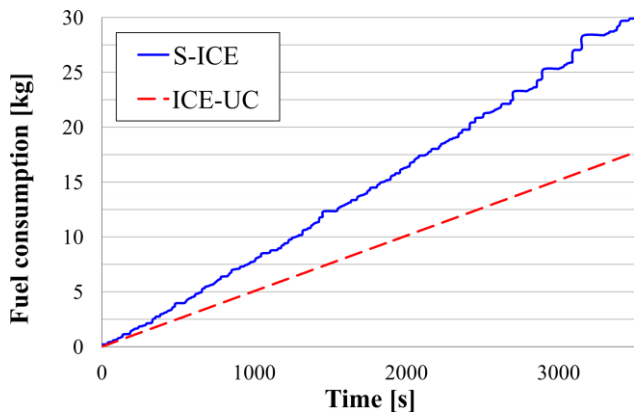

(a) ICE-UC Series Hybrid and FC-UC

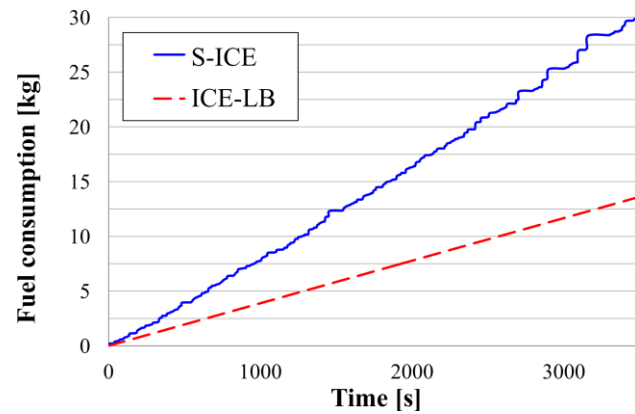

(b) ICE-LB Series Hybrid

Fig. 14. Fuel consumption during a 1-hour course of Line 1.

Table I – Weight, cost, efficiency and fuel consumption of the compared powertrains.

Powertrain	Component	Weight [Kg]	Cost [k€]	Efficiency [%]	Power [kW]	Fuel/day [Kg]/(€)	Payback time [years]
Standard ICE S-ICE	ICE	570	30	25	147	430 (650)	0
	Fuel (Diesel)	600	-	-	-		
	Tot. = 1.170	Tot. = 30.0	Tot. = 25				
ICE + ultracapacitor series hybrid ICE-UC	ICE	300	15	30	65	240 (320)	3.1
	EM ₁	290	5	90	65		
	PC _{EM1}	5	0.5	95	65		
	EM ₂	180	10	90	120		
	PC _{EM2}	25	5	95	120		
	PC _{uc}	25	5	95	60		
	UC	3.000	250	98	60 (10 kWh)		
	Fuel (Diesel)	300	-	-	-		
Tot. = 3.825	Tot. = 290.5	Tot. = 20					
ICE + Li-Ion battery series hybrid ICE-LB	ICE	250	14	31	50	180 (230fuel +50el)	3.0
	EM ₁	220	5	90	50		
	PC _{EM1}	5	0.5	95	50		
	EM ₂	180	10	90	120		
	PC _{EM2}	25	5	95	120		
	Battery	22.500	300	93	70 (300 kWh)		
	Fuel (Diesel)	250	-	-	-		
	Tot. = 23.430	Tot. = 334.5	Tot. = 23				
Fuel Cell + ultracapacitor FC-UC	FC	80	80	50	65	30 (150–200)	2.9
	PC _{FC}	80	10	88	200		
	EM ₂	180	10	95	120		
	PC _{EM2}	25	5	90	120		
	PC _{uc}	25	5	95	60		
	UC	3.000	250	98	60 (10 kWh)		
	Fuel (H ₂)	40	-	-	-		
	H ₂ tanks	100	1	-	-		
Tot. = 3.530	Tot. = 361.0	Tot. = 35					

In addition, a larger reduction in fuel consumption and pollution costs can be achieved if the hybrid powertrain is combined with an advanced propeller solution, like those considered in sub-section III-A, providing reduced power peaks and more advantages as regards comfort during docking, in the framework of pertinent innovative technologies and regulations [29]. As a conclusive important remark in examining the Table is that Fuel Cell solution appears a promising viable solution taking also into account that it is the sole all-electric propulsion solution excluding any onboard ICE with advantages in terms of lower noise, lower emissions and higher comfort.

V. FUTURE DEVELOPMENTS AND CONCLUSIONS

According to our design study, a hybrid powertrain base on a fuel cell and an energy storage device is the more appealing solution in terms of global (investment and running) costs and pollution effects, but ICE-hybrids are viable too, and can raise minor infrastructure problems, at least in a early introduction step. As already outlined, the prototypes under design are aimed at introducing in Venice advanced electric watercrafts. They constitute the first step of a plan aimed at converting the whole urban transportation to electric. The following steps will extend the adopted technologies to private waterbuses (providing service to/from the international airport), taxes, cargo vessels and municipal service crafts, private and sharing boats. This plan is very ambitious, but, if successful, it could dramatically change the appearance of Venice. The radical conversion to a general system of electric mobility will provide the best noise-free and pollution-free preservation of its unique artistic and historical heritage, for their citizens and tens of millions of visitors which stop over every year.

REFERENCES

- [1] "Geschichtliche Hintergründe" [Historical Background], Bayerische Seenschiffahrt. Retrieved 15 Mar. 2015. Available: <http://www.seenschiffahrt.de/de/unternehmen/geschichte.asp>, retrieved 15 Mar. 2015.
- [2] H. Buitelaar, "Texelstroom: Experience the island aboard a gas-electric hybrid ferry," *Maritime by Holland*, vol. 63, n. 8, Dec. 2014, pp. 18-23.
- [3] "News: Fuel cell boat passes pre-launch harbor tests," *Fuel Cells Bulletin*, vol. 2003, n. 10, Oct. 2003, p. 4.
- [4] "Environment and diversity key factors in US boat building," *Ship and Boat Int.*, n. NOV.DEC., Nov. 2007, pp. 42+44+46+48+49.
- [5] "Nuvera fuel cells for Fincantieri marine vessels," *Fuel Cells Bulletin*, vol. 2013, n. 12, Nov. 2003, p. 1.
- [6] "U212 / U214 Submarines, Germany," naval technology.com. Available: http://www.naval-technology.com/projects/type_212/, retrieved 15 Mar. 2015.
- [7] "MF Ampere – retning Oppedal," [MF Ampere, heading Oppedal], ferjebloggen.com (in Norwegian). Available: <http://www.ferjebloggen.com/?p=692>, retrieved 15 Mar. 2015.
- [8] "All-electric air supported hull vessel comes closer to reality," *Motor Ship*, vol. 94, n. 1103, Apr. 2014, p. 44. Available: <http://www.motorship.com/news101/ships-and-shipyards/all-electric-air-supported-hull-vessel-comes-closer-to-reality>, retrieved 15 Mar. 2015.
- [9] A. Kondo, Y. Hirose, "Effects of introduction of a water-bus system and transport policies on road traffic and the environment in urban areas," *Proc. Int. Conf. Urban Transport and the Environment for the 21st Century*, Lisbon, Portugal, 1998, pp. 115-126.
- [10] G. S. Spagnolo, D. Papalilo, A. Martocchia, "Eco friendly electric propulsion boat," *Proc. 10th Int. Conf. Environment and Electrical Engineering, EEEIC.EU 2011*, Rome, May 2011, Article number 5874699.
- [11] V. Stanciu, M. Chefneux, P. Anghelita, B. Varaticeanu, "Hybrid propulsion conceptual model for watercraft – Eco-boat," *Electrotechnica Electronica Automatica*, vol. 60, n. 4, 2012, pp. 78-88.
- [12] A. Del Pizzo, R. M. Polito, R. Rizzo, P. Tricoli, "Design criteria of on-board propulsion for hybrid electric boats," *Proc. 19th Int. Conf. Electrical Machines, ICEM 2010*, Rome, Sept. 2010, Article number 5607817.
- [13] N. Fonseca, T. Farias, F. Duarte, G. Gonçalves, A. Pereira, "The hidrocoy project - an all electric ship with photovoltaic panels and hydrogen fuel cells," *Proc. 24th Int. Battery, Hybrid and Fuel Cell Electric Vehicle Symp. Exhib. 2009, EVS 24*, Stavanger, Norway, vol. 4, 2009, pp. 2504-2516.
- [14] C.-L. Su, R.-H. Weng, "Voltage quality study of integrated power system for all-electric vessels using dynamic simulation techniques," *Advanced Materials Research*, vol. 433-440, 2012, pp. 2546-2550.
- [15] D. K. Lee, Y.-K. Jeong, J. G. Shin, D.-K. Oh, "Optimized design of electron propulsion system for small craft using the differential evolution algorithm," *Int. J. Precis. Eng. Manuf.*, vol. 1, n. 3, June 2014, pp. 229-240.
- [16] J. Carlton, *Marine Propellers and Propulsion*, Oxford, UK: Butterworth-Heinemann, 2007.
- [17] H. Amini, L. Sileo, S. Steen, "Numerical calculations of propeller shaft loads on azimuth propulsors in oblique inflow," *J. Mar. Sci. Technol.*, vol. 17, n. 4, Dec. 2012, pp. 403-421.
- [18] S. T. Maynard, "Power versus speed for shallow draft navigation," *J. Waterw. Port Coast. Ocean Eng.*, vol. 126, n. 2, Mar.-Apr. 2000, pp. 103-106.
- [19] P. Andresen, J. Friesch, J. J. Kappel, L. Lundegaard, G. Patience, "Development of a marine propeller with nonplanar lifting surfaces," *Marine Technology*, vol. 42, n. 3, July 2005, pp. 144-158.
- [20] B. L. Hutchison, D. L. Gray, S. Jagannathan, "New insights into Voith Schneider tractor tug capability," *Marine Technology*, vol. 30, n. 4, Oct. 1993, pp. 233-242.
- [21] N. Bianchi, S. Bolognani, B. Ružojčić, "Design of a 1000 HP Permanent Magnet Synchronous Motor for Ship Propulsion," *13th Int. Conf. Power Electronics and Applications, EPE '09*, Barcelona, Spain, Sept. 2009, Article number 5279055.
- [22] M. Barcaro, N. Bianchi, S. Bolognani, "Hybrid electric propulsion system using submersed SPM machine," *International Conference on Electrical Machines, ICEM 2008*, Vilamoura, Portugal, Sept. 2008, Article number 4800089.
- [23] T. Takamasa, T. Oode, H. Kifune, E. Shimizu, T. Hazuku, "Quick charging plug-in electric boat RAICHO-I," *2011 IEEE Electric Ship Technologies Symposium, ESTS 2011*, Alexandria, VA, Apr. 2011, pp. 9-11.
- [24] E. Shimizu, M. Nishimura, T. Oode, H. Kifune, T. Takamasa, T. Hazuku, "Navigation support system for electric boat," *4th IEEE Electric Ship Technologies Symposium, ESTS 2011*, Alexandria, VA, Apr. 2011, pp. 12-14.
- [25] T. Lamberti, L. Magistri, P. Gualeni, A. Da Chá, A. Calcagno, "Application of fuel cell system as auxiliary power unit onboard mega yacht vessels: A feasibility study," *Proc. Int. Conf. Design and Construction of Super and Mega Yachts*, Genoa, Italy, May 2013, pp. 101-110.
- [26] F. Balsamo, A. Brighenti, G. Landri, A. Paciolla, F. Quaranta, "Experimentation and measurements on the propulsion plant of a water bus in service on the "Canal Grande" in Venice," *CIMAC International Council on combustion engines*, Warsaw 23-24 May 1994.
- [27] F. Balsamo, A. Brighenti, G. Landri, A. Paciolla, F. Quaranta, "The propulsion of public transport vessels in coastal and inner waters: working data acquisition, elaboration and study of alternative solutions," *NAV 94*, Rome, 5-7, October 1994.
- [28] A. Paciolla, F. Quaranta, "On the choice of the high-speed diesel engines for the propulsion of small vessels," *CIMAC International Symposium On Small Diesel Engines*, Warsaw, 21 - 22 May 1990.
- [29] Y. Khersonsky, N. Hingorani, K. L. Peterson, "IEEE Electric Ship Technologies Initiative," *IEEE Industrial Applications Magazine*, vol. 17, n. 1, Jan/Feb. 2011, pp. 66-73.